

Product Code	Definition
EMK30 - KB	Axial Metal Expansion Joints 30mm Expansion Welding Ends
EMK30L - KB	Axial Metal Expansion Joints 30mm Expansion With Inner Sleeve Welding Ends
EMK60 - KB	Axial Metal Expansion Joints 60mm Expansion Welding Ends
EMK60L - KB	Axial Metal Expansion Joints 60mm Expansion With Inner Sleeve Welding Ends

## GENERAL

Axial expansion joints are designed to absorb expansion and compression movements in the longitudinal axial direction in the pipelines. Axial type expansion joints can absorb the vibrations in the pump, fan and pipe systems, and thermal expansions that will occur due to temperature difference by fixing a flat part of the pipeline between two points. Liner used in the axial expansion joints both ensures the flow to be laminar and increases the working life of the expansion joint. In the order phase, the total amount of motion, the type of fluid in the line, the location of use, the type of connection, the working pressure and the temperature of the system should be specified.



Standard Product Materials		Optional Product Materials
Bellows	1.4301 (AISI 304)	1.4541 / 1.4401 / Titanium / Incoloy 800H / Inconel etc.
Inner Sleeve	1.4301 (AISI 304)	1.4541 / 1.4401 / Titanium / Incoloy 800H / Inconel etc.
Welding Ends	1.0038 (St 37-2)	Stainless Steel

Design Parameters	
Design Pressure	16 Bar (1 Bar...40 Bar Optional)
Design Temperature	+20 °C (-90°C...+550 °C Optional)
Diameters	DN25 (1")...DN2500 (100")
Movements	30mm (-20, +10) / 60mm (-40, +20)
Design Standards	EJMA, EN 14917
Certifications	TSE, CE - Module H (Optional) , EAC

\*\*Please contact our sales team for your special requests.

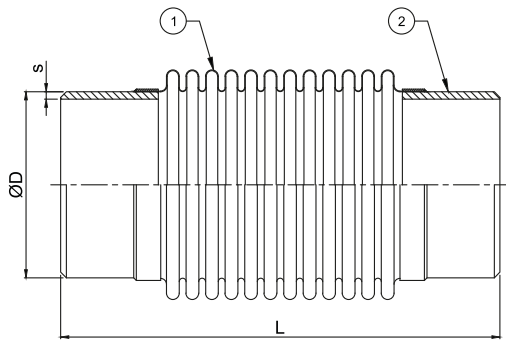

EMK...-KB

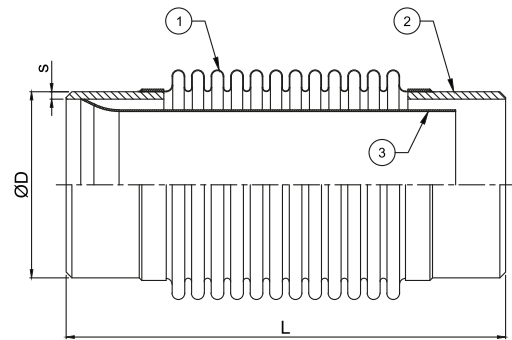

EMK...L-KB

Part Number	Specifications	
	Name	Material
1	Bellows	1.4301 (AISI 304)
2	Welding Ends	1.0038 (S235JR / St37-2)
3	Inner Sleeve	1.4301 (AISI 304)

Diameters		LENGTH (L = mm)				ØD (mm)	s (mm)	Effective Area (cm <sup>2</sup> )	Axial Spring Rate (N/mm)	
		EMK30-KB	EMK30L-KB	EMK60-KB	EMK60L-KB				X: 30mm	X: 60mm
		X: 30mm	X: 30mm	X: 60mm	X: 60mm					
DN25	1"	180		230	33,7	3,2	19,0	63,7	37,1	
DN32	1 1/4"	180		240	42,4	3,2	19,0	63,7	37,1	
DN40	1 1/2"	190		240	48,3	3,2	24,7	53,4	31,5	
DN50	2"	190		240	60,3	3,6	38,7	87,6	53,5	
DN65	2 1/2"	190		240	76,1	3,6	58,0	99,4	66,2	
DN80	3"	190		250	88,9	4	80,5	74,3	46,4	
DN100	4"	200		270	114,3	4,5	129,0	138,2	82,9	
DN125	5"	200		270	139,7	5	191,8	195,3	111,6	
DN150	6"	250		320	165,1	5	262,7	330,3	188,7	
DN200	8"	270		340	219,1	6,3	453,5	229,3	131,0	
DN250	10"	310		395	273	6,3	698,4	171,4	97,9	
DN300	12"	310		395	323,9	7,1	967,0	627,9	418,6	
DN350	14"	320		405	355,6	8	1149,6	807,1	448,4	
DN400	16"	320		405	406,4	8	1517,7	701,6	400,9	
DN450	18"	330		420	457	8	1884,2	836,0	477,7	
DN500	20"	340		430	508	8	2282,5	1043,5	695,7	

\*\* X value represents axial movement. Please contact our technical department for different movement requirements.