

## LS30 CONTROLLER INSTALLATION AND OPERATION GUIDE

v1.03/310123

- READ THIS DOCUMENT CAREFULLY BEFORE COMMISSIONING THE DEVICE,
- ELECTRICAL CONNECTION OF THE DEVICE MUST BE MADE BY AUTHORIZED PERSONNEL OTHERWISE THERE IS DANGER OF SERIOUS INJURY OR DEATH,
- THIS DOCUMENT LATER SHOULD BE KEPT IN AN EASILY ACCESSIBLE PLACE,
- ENERGY STRICTLY SHOULD NOT BE GIVEN TO THE DEVICE EXCEPT FOR CONNECTION SCHEMA AND TECHNICAL INFORMATION GIVEN IN THIS GUIDE,
- APPLICATIONS DEFINED IN THIS GUIDE AS INAPPROPRIATE CAN TERMINATE WARRANTY OF PRODUCT,
- IF YOU THINK THIS GUIDE IS NOT HELPFULL PLEASE CONTACT US FROM OUR CONTACT INFORMATION,

## **INDEX**

**page**

---

1. GENERAL	3
2. MOUNTING	4
3. ELECTRICAL CONNECTIONS	7
4. PROGRAMMING	13
5. ADJUSTMENT of SENSOR REFERENCE VALUES	20
6. MALFUNCTION	26

## 1. GENERAL

### 1.1 Device Description

LS30 Controller devices are the devices that transfer data to user and automation systems by using the data received from MLG30 and LS30 Level Control Equipments. Sensor data related with level sensors are transferred to LS30 Controller and level changes can be monitored from display screen. With this data can be controlled by 3 each NO(Normally Open) + NC(Normally Closed) relay contacts and motor, pump, on-off valve, solenoid valve, audible or/illuminated alarm type of three different devices that has been integrated to the device. Also by means of 4-20 mA, 0- 10 V analog signal outputs or RS 485 Modbus communication protocol connection can be made with automation systems.

### 1.2 Block Diagram

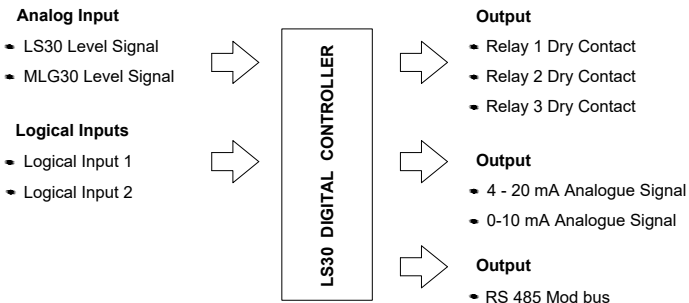

### 1.3 Technical Informations

Analogue Input	: LS30 / MLG30 Sensor Input,
Logical Inputs	: 2 Pieces Logical Signal Inputs,
Relay Outputs	: 3 Pieces NO+NC Dry Contact Relay Outputs (250 VAC / 3A max.)
Analogue Outputs	: 4-20 mA / 0-10 V Analogue Output Signal
Serial Communication	: RS485 Modbus Serial Communication
Supply	: Standard 230 VAC ( $\pm$ %10) Optional 24 VDC ( $\pm$ %10)
Power Consumption	: 4-5 W
Working Temp.	: 0 +50 °C
Storage Temp.	: -40 +70 °C

### 1.4 Content of the Package

LS30 Controller is being shipped with connection with 2 each fixing stands and with this document within a carton box.

## 2. MOUNTING

### 2.1 Dimentions

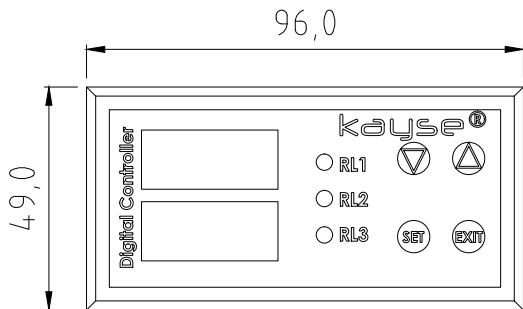

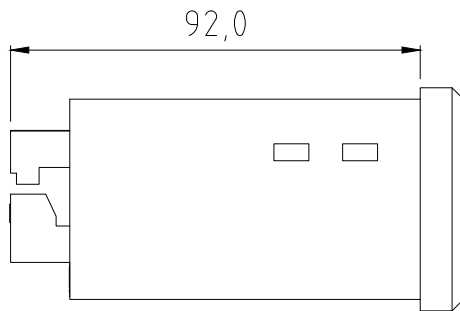

## 2.2 Panel Cutting Dimensions

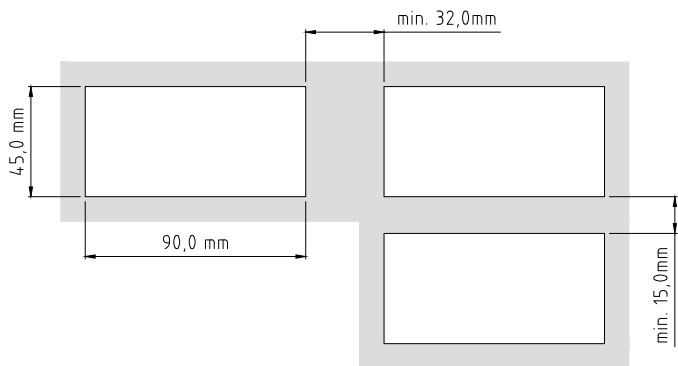

## 2.3 Assembly Environment and the Working Conditions

LS30 Controller devices should be definitely used with at least one panel protection class IP65 or by installing within the box. In contrary the oxidation can occur in the electrical equipments.

Using of LS30 Controllers in medium of big evaporation can not be recommended from the point of life cycle.

## 2.4 Mounting Type

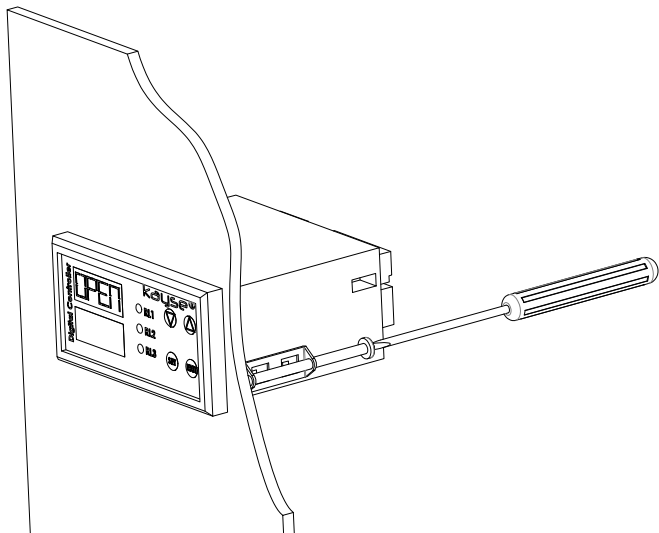

## 2.5 Assembly Sequencing

- Place the device to the panel that has been manufactured according to 2.2 Panel Cutting Dimensions place the device by facing the screen yourself,
- According to the 2.4 Mounting Type tighten the fixing stands within box by means of a suitable screw driver by installing the side channels located at the sides of device,
- In order to make the electricity connection remove the terminals at the aft of device,
- By means of a suitable screw driver make connections as per 3. Electrical Connections,

### 3. ELECTRICAL CONNECTIONS

#### 3.1 Basic Electrical Connections

The electricity connections of device should be made by an authorized electrician. In addition cable connections should be maximum 1.5 mm<sup>2</sup> in cross section. In contrary terminal connections can not be made.

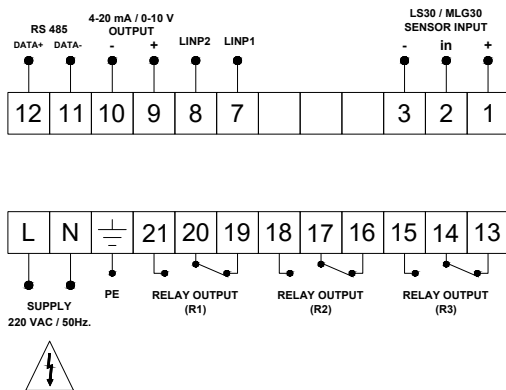

#### 3.2 Supply Voltage Connections

Energizing of device other than supply voltage tolerances may severely damage the device. At connection of devices with 220 VAC measures should be taken against electrical shock.

At devices with 24 VDC supply voltage, the directions of -/+ poles does not differ. Also 24 VDC models can operate with 24 VAC voltage.

220 VAC

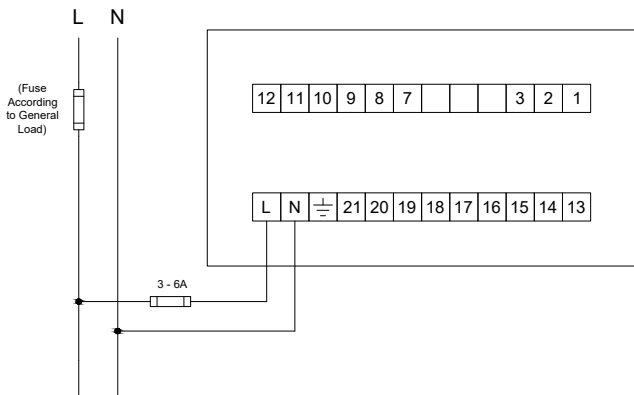

24 VDC

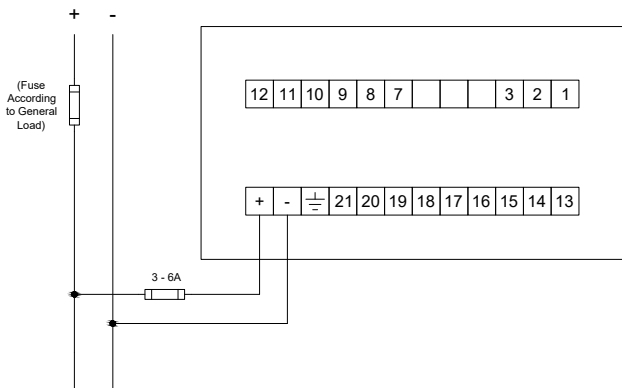

## 3.3 Sensor Connections

### 3.3.1 Sensor Connections for LS30 Level Control Equipments

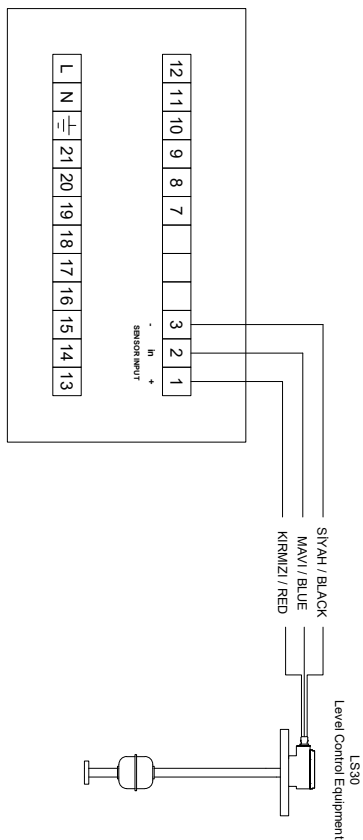

### 3.3.2 Sensor Connections for MLG30 Level Control Equipments

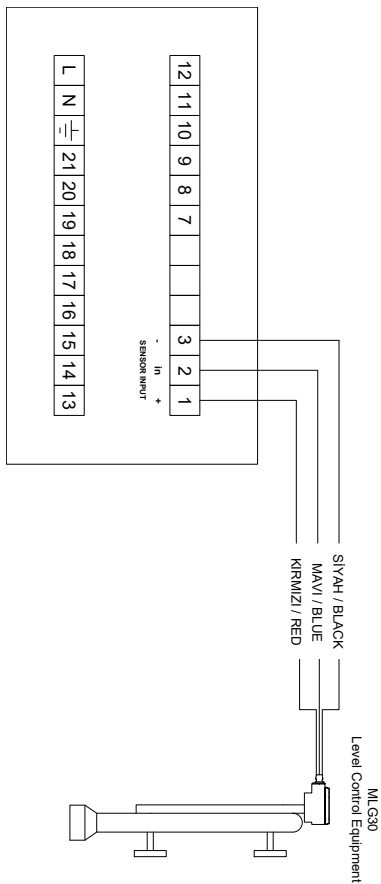

### 3.4 Digital Input Connections

Please ask for digital input connections.

### 3.5 Relay Output Connections

Pump, solenoid valve or siren type of coiled and high current consumption devices that will be controlled with relay outputs should be definitely controlled by auxiliary relay or contactor indirectly. In contrary relay contacts may damage or by sticking and by making nozzle may cause operation of any device that should not operate and therefore the system can be severely damaged (for example overspill of depot).

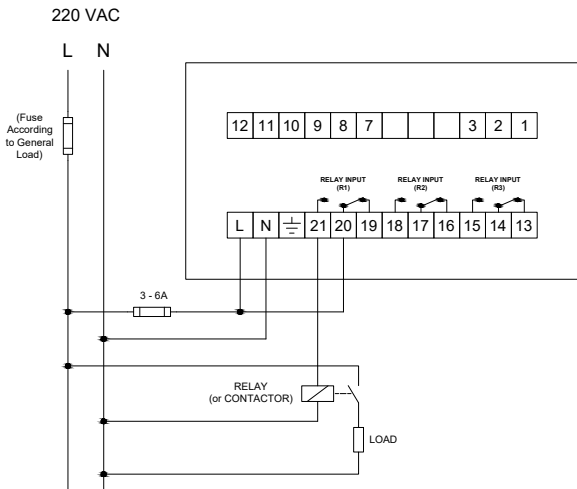

**Note:** It has been drawn by considering that all of equipments of connection schematic are operating with 220 VAC power. According to different power values connection way may vary.

### 3.6 Analogue Output Connections

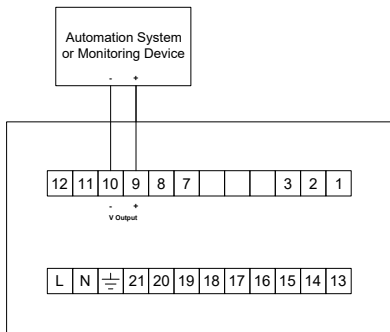
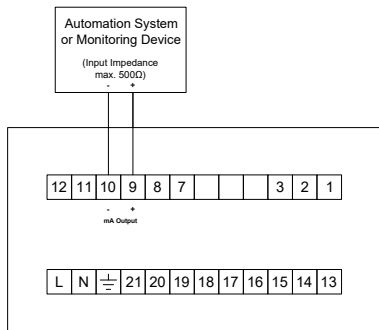

For control of '**mA**' outputs in case there is not automation connection measurement can be taken from 9&10 terminals of '**mA**' stage of measurement devices. The measurement values should give results close to below mentioned formula.

(for 4-20 mA) mA value =  $0,16 \times (\% \text{ value on the display}) + 4$

(for 20-4 mA) mA value =  $0,16 \times (100 - \% \text{ value on the display}) + 4$

For controlling of 'V' outputs in case there is not automation connection measurement can be taken from 9&10 terminals of 'V DC' stage of measurement devices. The measurement values should give results close to below mentioned formula.

(for 0-10 V) V value = % value on the display / 10

(for 10-0 V) V value = (100 - % value on the display) / 10

### 3.7 Connection of RS485 Serial Communication Interface

Please ask for RS485 Interface Connection.

### 3.8 Cabling

The cable connections should be 1,5 mm<sup>2</sup> in cross section. In contrary the terminal connections can not be made. At general cabling multi wired and tinny cables should be preferred for extending life cycle of device and to eliminate discontinuity possibility that may occur by oxidation. At LS30 and MLG30 sensor input connections 3x0,75mm<sup>2</sup> cross section cables can be used.

## 4. PROGRAMMING

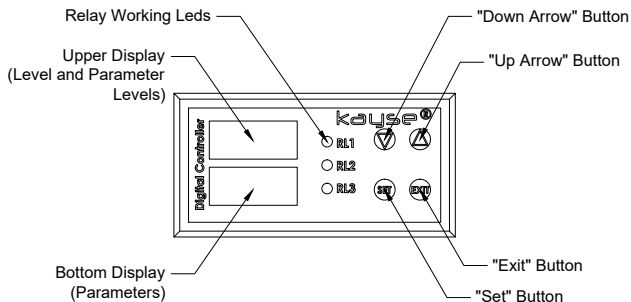

## 4.1 Using the Keypad

### 4.1.1 'Set' Button

With 'Set' button, entry to menu transition between parameters and approval transactions can be made. For entry to menu 'Set' button is pressed until 'R1' on parameter appears on screen. After entry to menu the transition between parameters is made by pressing 'Set' button. At each pressing of 'Set' button the parameter value at the top line of screen are stored in memory and approved.

### 4.1.2 'Up Arrow' Key

After entry to menu by pressing with 'Up Arrow' button this is used to increase numerical parameter value and to advance other parameter values. The values changed with 'Down Arrow' button are stored into memory by approving with 'Set' button.

### 4.1.3 'Down Arrow' Key

The 'Down Arrow' button is used for decreasing the numerical parameter values and to backspace other parameter values after entry to the menu. The values changed with 'Down Arrow' button are stored into memory by approving with 'Set' button.

### 4.1.4 'Exit' Key

'Exit' button is used for exiting from menu and to return to main operating screen and exiting without storing of other changed parameter values.

## 4.2 Menu System

There are 3 different menu levels for LS30 Controller programming.

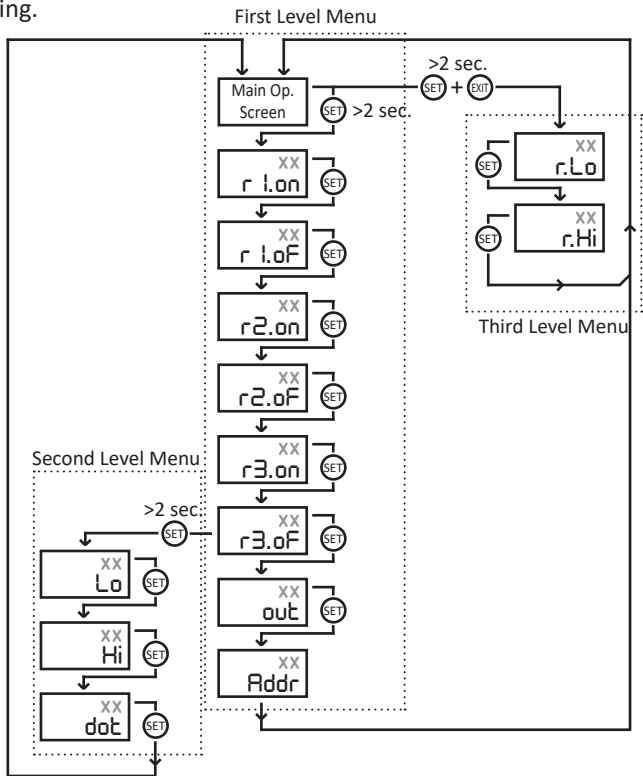

**for First Level Menu**, 'Set' button should be pressed 2 seconds at main operating screen.  
**for Second Level Menu**, while at 1st level menu at 'r3.of' parameter 'Set' button should be pressed 2 seconds.

**for Third Level Menu**, at menu operating screen 'Set' and 'Exit' buttons should be pressed together for 2 seconds.

### 4.3 General Parameters List

Parameters	Setting Range	Factory Settings	Explanation
r1.on	0-9999	0	Relay 1 On Value
r1.oF	0-9999	0	Relay 1 Off Value
r2.on	0-9999	0	Relay 2 On Value
r2.oF	0-9999	0	Relay 2 Off Value
r3.on	0-9999	0	Relay 3 On Value
r3.oF	0-9999	0	Relay 3 Off Value
out	4-20, 0-10, 20-4, 10-0	4-20	Analogue Output
Addr	1-100	1	RS485 Address
Lo	0-9998	0	Min. Measurement Value
Hi	0-9999	100	Max. Measurement Value
dot	0 or 1	0	Decimal Operating Value

#### 4.3.1 'r1.on' Parameter

For relay 1 it is the parameter determining set value. It determines at which point the devices connected to the adjusted value relay 1 will start.

#### 4.3.2 'r1.of' Parameter

For relay 1 it is the parameter determining reset value. It determines at which point the devices connected to the adjusted value relay 1 will stop.

#### 4.3.3 'r2.on' Parameter

For relay 2 it is the parameter determining set value. It determines at which point the devices connected to the adjusted value relay 2 will start.

#### 4.3.4 'r2.of' Parameter

For relay 2 it is the parameter determining reset value. It determines at which point the devices connected to the adjusted value relay 2 will stop.

#### 4.3.5 'r3.on' Parameter

For relay 3 it is the parameter determining set value. It determines at which point the devices connected to the adjusted value relay 3 will start.

#### 4.3.5 'r3.of' Parameter

For relay 3 it is the parameter determining reset value. It determines at which point the devices connected to the adjusted value relay 3 will stop.

**Note:** Relay on and off values for the relay not to be operated should be adjusted as '0'. For example if relay 3 should not be operated the 'r3.on' and 'r3.of' parameters should be adjusted as '0'.

### 4.3.7 'out' Parameter

It is the parameter determining the type of analog output. The analog output value is being shipped adjusted at 4-20 mA at default value. In order to make transition between mA or V outputs the dip switch back of device should be replaced together with 'Output' parameter.

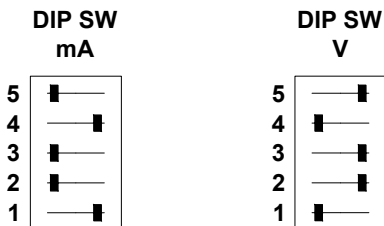

According to Adjustment Field;

4-20 : Adjusts the output values as 4-20 mA,

0-10 : Adjusts the output values as 0-10 V,

20-4 : Adjusts the output values as 20-4 mA,

10-0 : Adjusts the output values as 10-0 V,

### 4.3.8 'Addr' Parameter

It is the addressing parameter with RS485 Modbus serial communication protocol.

### 4.3.9 'Lo' Parameter

It is related with lower scale value of level quantity indicated at main operating screen. While liquid level is at minimum other parameter that should be written on screen is determined with this parameter. For example the level measurement device can not start to measure at the lowest part of depot because of its structure more accurate results can be obtained by assigning 'Lo' at the level of start. This parameter as of operating principle should be adjusted as a higher value than 'Hi' parameter.

According to below motioned sample while the fullness ratio of level control device is 15% it will be detected as 0%. If 'Lo' parameter is adjusted '15' the correct result can be traced at LS30 controller screen.

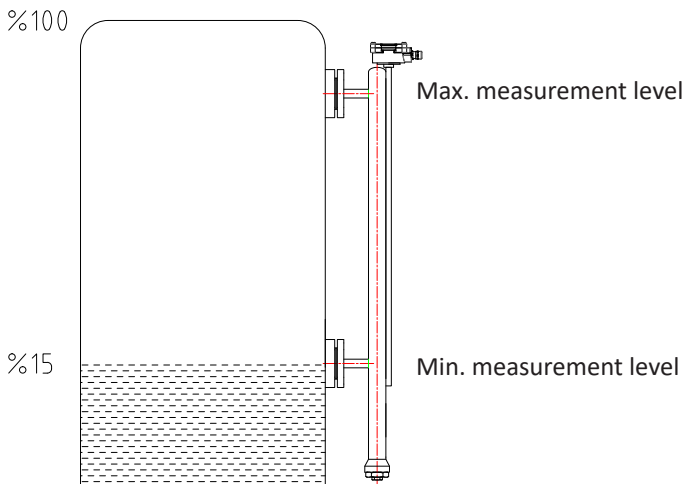

### 4.3.10 'Hi' Parameter

It is related with upper scale value of the level indications indicated at main operating screen. While liquid level is at maximum the value to be indicated on screen is determined with this parameter. This parameter should be adjusted lower than 'Lo' parameter value as an operation principle.

'Hi' parameter is shipped by adjusting 100 default value. By this means the depot level can be traced on screen in percentage. When the units like liter, cubic meter, kilogram, tons, meter etc. type of different measurement units will be used by increasing 'Hi' parameter, it may be used in different operation ways. For example for a depot with a 5m height if the 'Hi' parameter is adjusted as 5000 the water level can be traced in mm.

### 4.3.11 'dot' Parameter

It is used to indicate the decimal values of the screen. After the stop decimal value of single digit can be indicated.  
(For example 56,4)

According to Adjustment Field;

- 0 : No decimal value is indicated,
- 1 : Single digit decimal value is indicated,

## 5. ADJUSTMENT of SENSOR REFERENCE VALUES

The sensor reference values are adjusted with a default value to give min. 0% scale value, 100% scale level at max. and shipped. For healthy level measurement reference values should be adjusted accurately.

**Note: If contrary isn't mentioned in this guide don't change references.**

When reference menu is entered parameter transitions should be made rapidly. In contrary in a short while as the device will return to main operating screen automatically the adjustments can not be made accurately. For this reason before transition to this transaction preparation should be made.

### 5.1 Adjustment of Reference Value of LS30 Controller at LS30 Level Control Equipments

- When the reference values of LS30 Controller is being adjusted that has been connected to LS30 Level Control Equipments, by removing the LS30 Level Control Equipments from depot its float shuld be taken at a place where it can move easily and rapidly by hand,
- The float is moved to lowest point,

LS30  
Level Control Equipment

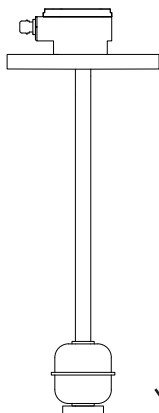

↓ The float is moved  
to lowest point

- For entry to reference menu 'Set' and 'Exit' buttons are pressed together until 'r.lo' parameter is indicated on screen,
- While the float at lowest point 'Set' button is pressed one more time,
- When 'r.hi' parameter is indicated on screen by taking the float to the top point 'set' button is pressed rapidly and the main operating screen is returned,

LS30  
Level Control Equipment

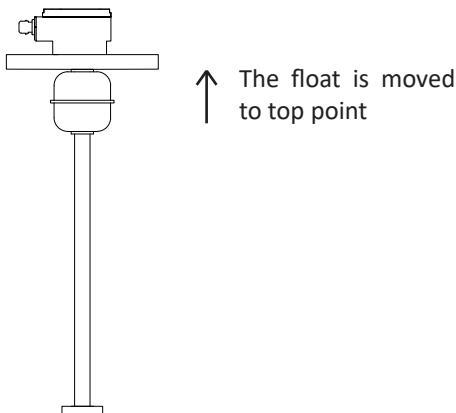

## 5.2 Adjustment of Reference Values of LS30 Controller at MLG30 Level Control Equipments

By zooming the buoy until it contacts to sensor part (the long pipe piece that the orange junction box that cable connections are made) assembled next to MLG30 Level Control Equipment, the reference adjustments will be made.

- When the reference values of LS30 Controller connected to MLG30 Level Control Equipment are being adjusted the float within MLG30 Level Control Equipment should be removed.
- The float is brought closer to contact to the lower part of sensor over the buoy level indicator,

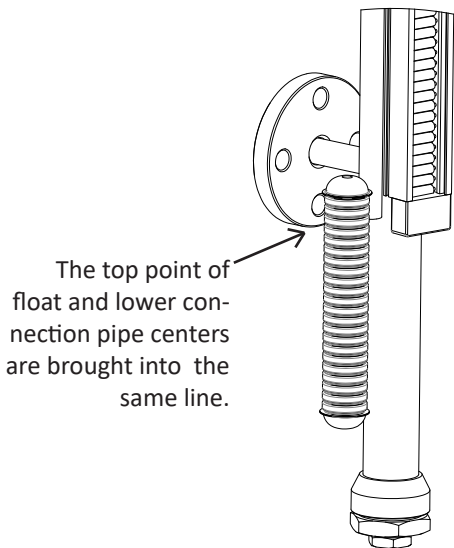

**(ATTENTION :**

The float should be kept in a manner its magnetic part facing upward. For determination of magnetic part an iron material can be used).

- For entry to reference menu 'Set' and 'Exit' buttons are pressed together until 'r.lo' parameter appears on screen.
- 'Set' button is pressed once when float is at lowest point,
- When 'r.hi' parameter appears on screen by moving buoy rapidly to the top point 'Set' button is pressed once again and main operating screen is returned,

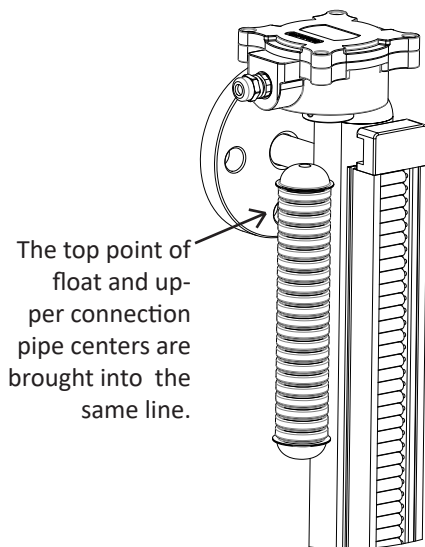

The top point of float and upper connection pipe centers are brought into the same line.

**(ATTENTION :**

The float should be kept in a manner its magnetic part facing upward. For determination of magnetic part an iron material can be used).

### 5.3 Adjustment of Reference Values Independent of Level Control Equipments

When the LS30 and MLG30 Level Control Equipments are not intervened by hand adjust the reference values as follows;

- By opening approximately 5-6 mm of two ends of 10 cm cable piece and prepare it (It should be max 1,5 mm<sup>2</sup> cross section for easy asassembly).
- For accurate are installing of cables properly to the triple terminal that the cable connection is made (terminal 1-3) remove them in order to avoid confusion,
- Install one end of cable piece prepared to terminal 2 and other end to terminal 3.

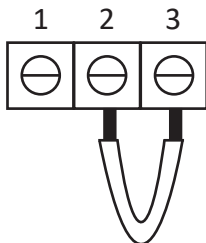

- 'Set' and 'Exit' buttons on LS30 Controller are pressed together until 'r.lo' parameter appear on screen,
- Pres 'Set' button for a short time and 'r.hi' parameter will appear on screen,
- Contact the cable that had been contacted to terminal 3 previously to terminal 1 with a rapid transition,

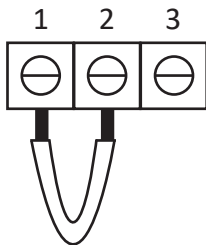

- Press Set button for a short time upon seeing of '100' value on top screen sensor connections can be made again.

## 6. MULFUNCTION

In trouble shooting make sure that the floats of LS30 and MLG30 (whichever is being used with LS30 Controller) Level Control Equipments are operating accurately. The wrongly selected, that does not float or defective floats prevent you to take measurement (see assembly and user guide for MLG series level control equipments).

### 6.1 General Multifunction Codes

#### 6.1.1 'Open' Multifunction Code

At errors related with sensor or sensor reference that can be detected by device the 'Open' failure code flashes at the upper display. This may come to the meaning that the sensor connections are not made correctly or brokerage at cables.

- Primarily make sure that sensor connections are made as per **3.3.1** or **3.3.2** in sequence,
- If you are sure that the connections are made as per sequence make sure that your cable is not broken,
- If you are sure that cable is not broken make sure that the reference values are adjusted accurately according to adjustment of '**5. Adjustment of Sensor Reference Values**',

#### 6.1.2 'err' Multifunction Code

In case of adjustment of relay parameters at equal values 'err' failure code appears in lower display. The relay on and off values should be definitely adjusted at different values.

These values can only be adjusted in same values as '0' only when the operation of relays are not desired.

## 6.2 Multifunction Dedection

'Open' inscription appears on screen,	You can solve the problem according to '6.1.1 Open Multifunction Code'. If you can not solve go to 6.4.
'err' inscription on screen,	You can solve the problem according to '6.1.2 err Multifunction Code'. If you can not solve go to 6.4.
No display on screen when energized,	Make sure that supply voltage is reached properly to LS30 Controller. If the energy is reached properly the LS30 Controller can be defective. Go to 6.4.
Relays do not operate even if we have entered relay on off values,	Cut the energy of LS30 Controller. Afterwards remove the lower terminal from its place that relay that energy connection is made and that relay outputs are connected. Take measurements from terminals 20&19, 17&16, 14&13 at $\Omega$ scale of measurement device. At all measurements you should read short circuit (resistance values close to zero). Relay that zero vales are not read can be defective, go to 6.4.
Although the level quantity is different continuous '100' value appear at upper display,	Replace the connections of 1 and 2 terminals of LS30 Controller. If you can not solve problem make sensor defect determination as per 6.3.

<p>Although the level quantity is different continuous '0' value is read at upper display,</p>	<p>Replace the connections of 3 and 2 terminals of LS30 Controller. Make sure that buoy of level control device is floating. (Refer to assembly and user guide of MLG Series Level Control devices). If you can not solve problem make sensor defect determination as per 6.3.</p>
<p>When depot is empty if it reads full, when empty reads full when less than half depot it reads more than half depot or when it is less than half depot it reads more than half depot type of adverse level indications,</p>	<p>Replace the connections of 1 and 3 terminals of LS30 Controller). If you can not solve problem make sensor defect determination as per 6.3.</p>
<p>We can not establish proper communication from automation system with analog output,</p>	<p>Make sure that analog output type is the same with your automation system. If the analog output at LS30 Controller has been adjusted as 'mA' no correct data can be obtained from automation system reading 'V'. In the same way if the analog output is adjusted as 'V' output no correct data can be obtained from automation system reading 'mA'. If analog signal types are different change analog output type according to 4.2.7 Also Control that LS30 Controller gives analog output with signal measurement device (See 4.2.7). If you can not solve go to 6.4.</p>

### 6.3 Determination of Sensor Defects

The resistance value ( $\Omega$  ohm) between each of the red, blue and black cables coming from sensor should be read. Total resistance value is directly proportional with sensor length and 1 cm is determined as 5  $\Omega$ .

Principle measurement of sensor connections should be made as follows;

- (Red & Blue  $\Omega$  Value) + (Black & Blue  $\Omega$  Value) =(Red & Black  $\Omega$  Value)

For example if sensor length is 2 meters and the fullness ratio of depot is 75% measurements should be made as follows;

- Red & Black : Should be measured as 1 k $\Omega$  ( $\pm$  5%),
- Black & Blue : 750  $\Omega$   
(Total resistance of 1 k $\Omega$  x 75% fullness ratio)
- Red & Blue : 250  $\Omega$   
(Total resistance of 1 k $\Omega$  x 75% free space)

If these measurement values can not be reached you can go to 6.4

### 6.4 Things To Be Done Before Service

If no solution is reached and if defect determination is made as per defect determination;

- Note the information related with the failure,
- Note the label and serial number of the device,
- By using the communication data overleaf this document contact factory,

**NOTES :**

---

**NOTES :**

kayse®

KAYSE ENDÜSTRİYEL MAM. SAN. TİC. A.Ş.

Tepeören İstanbul Tuzla Organize Sanayi Bölgesi (İTOSB)  
7.Cadde No:4 34959 Tuzla / İSTANBUL / TÜRKİYE

Tel : +90 216 304 00 65 | export@kayse.com.tr  
Fax : +90 216 304 14 54 | www.kayse.com.tr