

LT-RL10

Radar Level Sensor

4...20mA / HART two wire

kayse[®]
QUALITY MAKES DIFFERENCE



Technical Specifications

Measuring range	up to 30 meter
Accuracy	± 5mm
Process connection	Threaded G 1 ½
Process pressure	-1 ... 3 bar
Process Temperature	-40...130°C
Operating frequency	26 Ghz
Measuring angle	22°
Power supply	14...36V DC / optional 220V AC
Protection class	Housing IP67, antenna IP68

Application Areas

LT-RL10 is an ideal sensor for measurement especially of aggressive liquids. The electronic amplifier is configured for particularly difficult measurement conditions. By this means, LT-RL10 is one of the most useful sensor in measuring up to 30m especially of difficult liquids, aggressive substances such as acid and caustic and of all kind of chemical mixtures and similar liquids. Due to its small dimensions, small dead zone and simple mounting options, it is particularly preferred in small tanks.

Measuring Principal

Powerful radar waves with short pulses are sent through the antenna system to the product surface. These pulses are reflected by the product surface and received again by the antenna system. The level is measured depending on the period between the time of sending and sensing of the pulses.

Advantages

- Simple mounting
- Non-contact measuring principle
- High sensitivity
- Maintenance-free structure
- Independent of steam, pressure, temperature and gas

Housing and Materials

Sensor bodies are manufactured in accordance with the demands of the customer from single or dual-cell plastic, aluminium or stainless steel material. The plastic housing meets the requirements of protection class IP66 and the aluminium and stainless steel housing the protection class IP67. All wet surfaces of the sensor is made from PP and PTFE material. All sealing gaskets can be manufactured as Viton and silicon

Electronic Options

Sensor electronics are available according to customer demands and process requirements as two-wire or four-wire 4...20mA/HART. They're gel filled and protected against moisture and vibration.

Certificates

LT-RL10 has an ATEX approval for use in hazardous areas. The instrument also has CE approvals for EMC Directive 2004/108/EC EN61326-1: 2006 EN61326-2-2: 2006 and Low voltage Directive 2006/95/EC EN 61010-1: 2010.

Installation

For installation on the silo, the sensor should be placed accurately to the centre of half the diameter of the silo. Furthermore, the mounting axis of the sensor must be at least 200mm from the silo wall. For assembling closer to the wall, special attention should be paid to any surface that may cause failure signal echos.

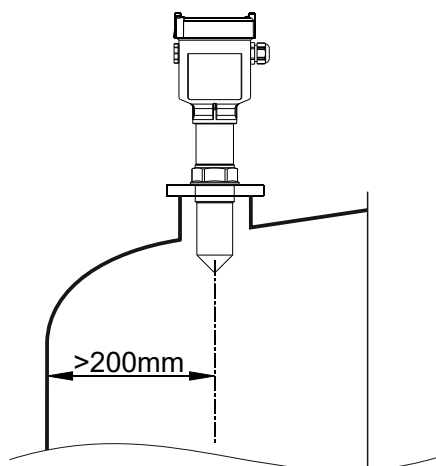

Electrical Connection

The sensor has a system known as two-wire which is operateable with 14..36V DC and which has an 4...20mA output on the same line. The (+) end of the power supply is directly connected to the sensor end 1 and PLC, DCS, indicator and control devices are serially connected to the (-) line 2.

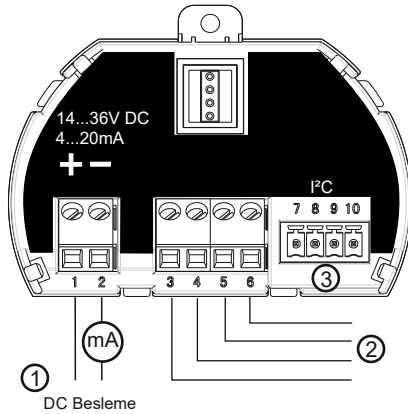

- 1- Supply / analog output
- 2- Exterior indicator output
- 3- Interface connection socket

Energy Supply Table / Accuracy Diagram

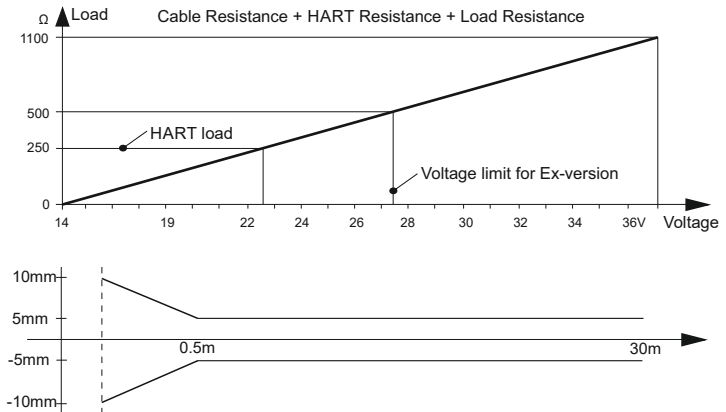

Adjustment with MICROCOM

The basic settings of the sensor can be easily done via the display and adjustment module MICROCOM with different menu language. The measuring range, the product type and the min. and max. values can be easily set. The space to the surface, fullness from ground to top, volumetric values and scaled data and values can be monitored on the display. Many parameters such as signal strength, error codes, simulation can be set under the diagnostic menu and settings such as suppression of faulty echos, type of current output, distance correction setting, reset, enter the PIN etc. can be adjusted under the service menu.

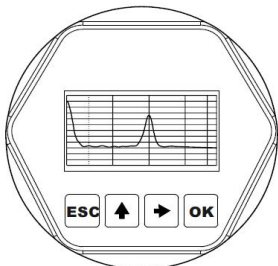
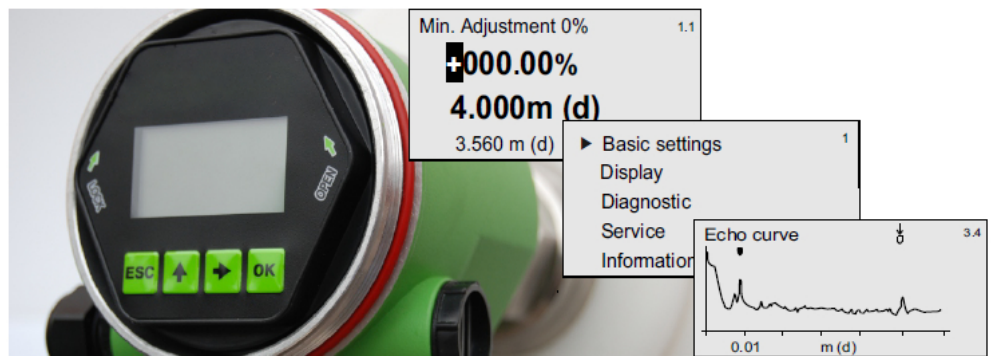

- OK** allows you to enter into the programming mode and to confirm the programming option and the parameter changes.
- allows you to select the programming options and the parameter values to be entered, to read off the parameter contents and to go to the next page.
- ↑** allows you to change the parameter values.
- ESC** allows you to revert from the programming mode to the upper menu.

Microcom Adjustment Module

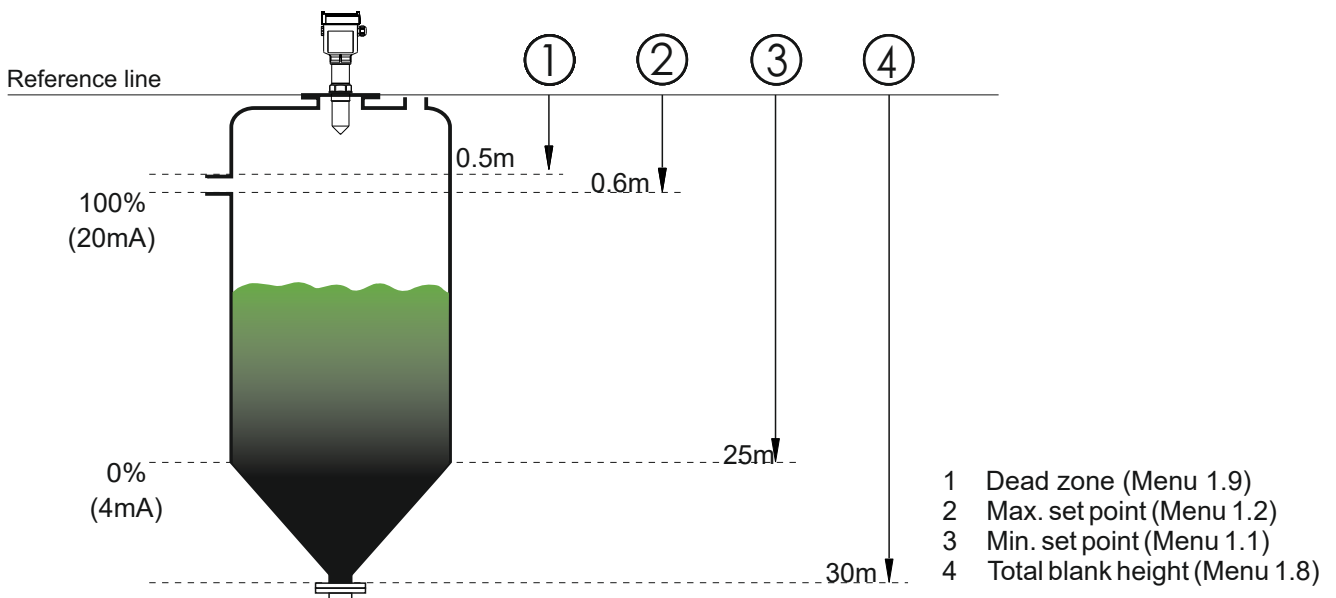

Connection and Adjustment via PC

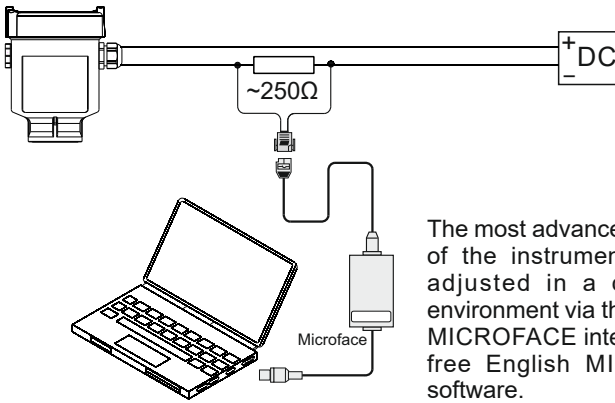

The most advanced settings of the instrument can be adjusted in a computer environment via the optional MICROFACE interface with free English MICROWIN software.

Adjustment with HART Handheld Terminal

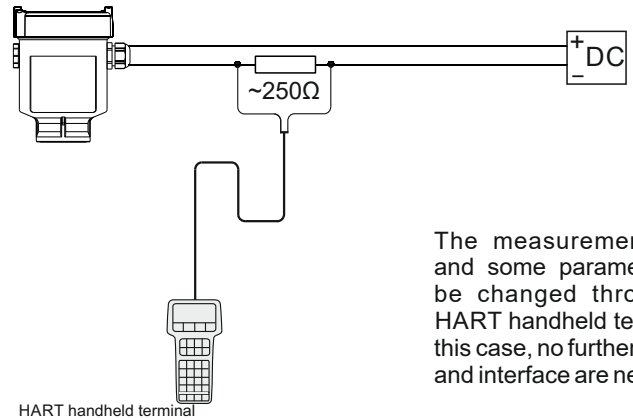

The measurement range and some parameters can be changed through the HART handheld terminal. In this case, no further software and interface are needed.

HART handheld terminal

Adjustment with Software

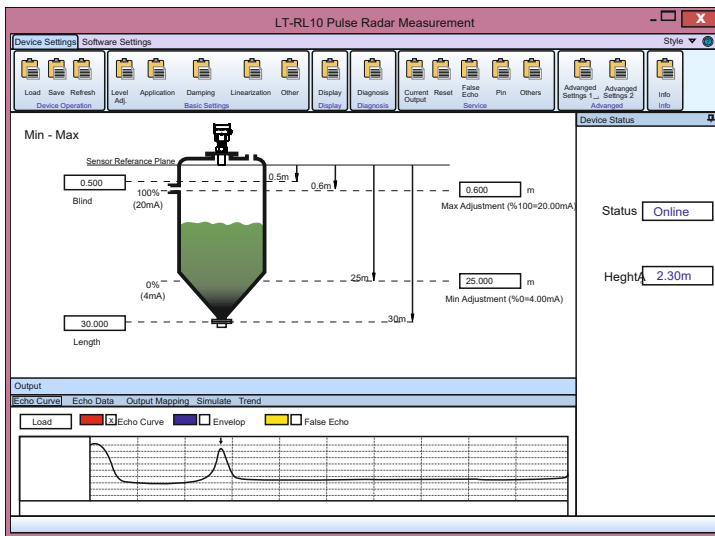

Advanced Parameter Setting

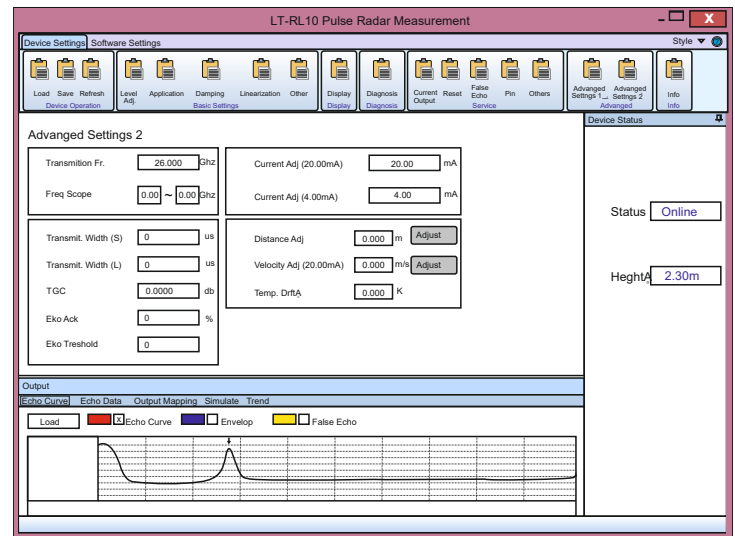

Technical Dimensions

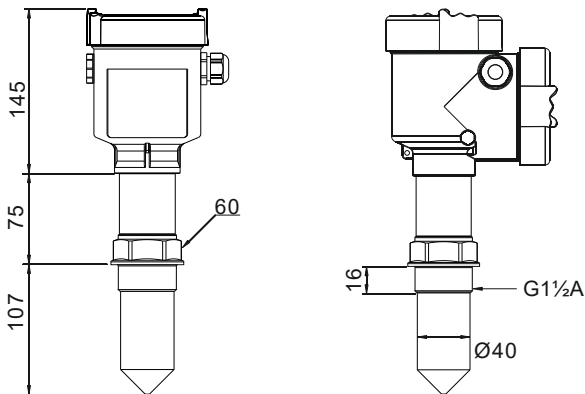

Technical Dimensions (Housing)

Single Chamber Housing

Double Chamber Housing

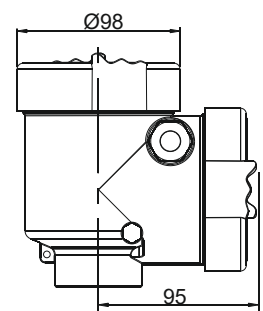
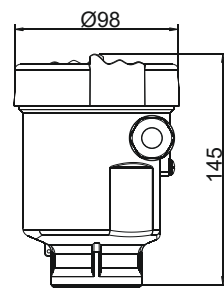

Various Applications / Considerations

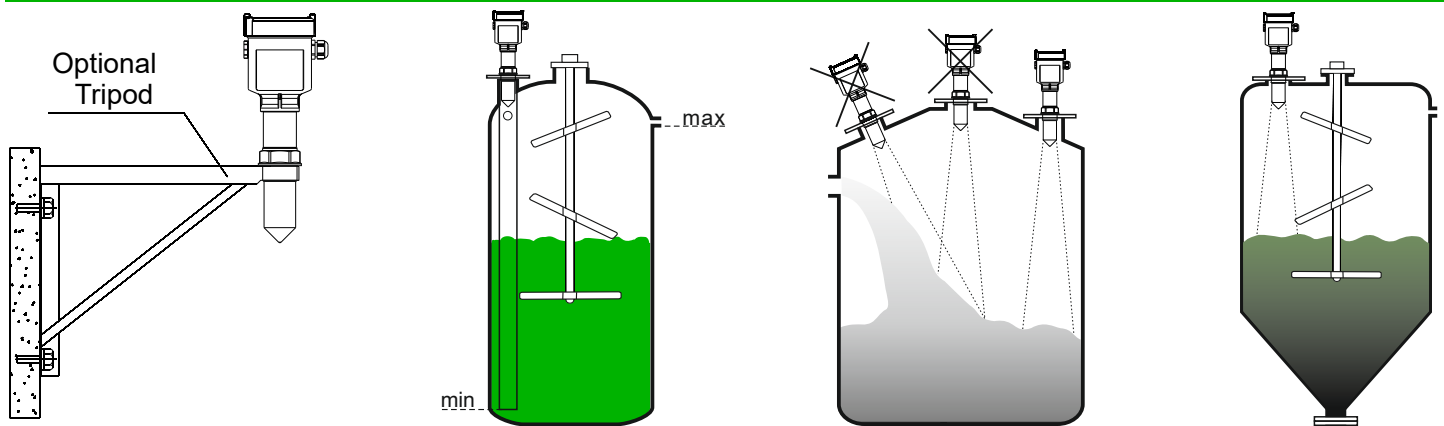

Model: LT-RL10 (10/20/30m)**Explosion Proof Approval**

- P - Standard (Without Approval).....
 G - ATEX II 1G Ex ia IIC T6...T3 Ga.....
 D - ATEX II 1D Ex ia IIIC T76°C...T146°C Da.....

Types of Antenna / Material

- A - Plastic Sealed Ø 44mm (IP68) / PVDF
 B - Plastic Sealed Ø 44mm (IP68) / PFA.....

Process Connection / Material

- GDX - Thread G 1 1/2 / PVDF.....
 NDX - Thread 1 1/2 NPT / PFA.....
 FCT - Flange DN50 / PTFE.....
 FDT - Flange DN80 / PTFE.....
 FXX - Special Connection.....

Electronic

- B - 4...20mA / HART Two wire 14...36VDC.....
 C - 4...20mA / HART Four wire 14...36VDC.....
 D - 4...20mA / HART Four wire 198...242VAC.....

Housing / Protection

- A - Aluminium / IP67.....
 B - Plastic / IP66.....
 D - Aluminium Two Chamber / IP67.....
 G - Stainless Steel 316L / IP67.....

Cable Entry

- M - M20x1.5.....
 N - 1/2 NPT.....

Display / Programming

- A - Yes.....
 X - No.....

Measurng Range—

- 1 - Up to 10m.....
 2 - Up to 20m.....
 3 - Up to 30m.....

MP55								
------	--	--	--	--	--	--	--	--

Notes:

- ATEX instruments can be used with only "B" Electronic and "A" "G" Housing
 -Four wire is only used with "D" Housing