



# kayse®

QUALITY MAKES DIFFERENCE

## EXPANSION JOINTS

PRODUCT CATALOGUE



[www.kayse.com.tr](http://www.kayse.com.tr)





| ALL AROUND  
THE WORLD

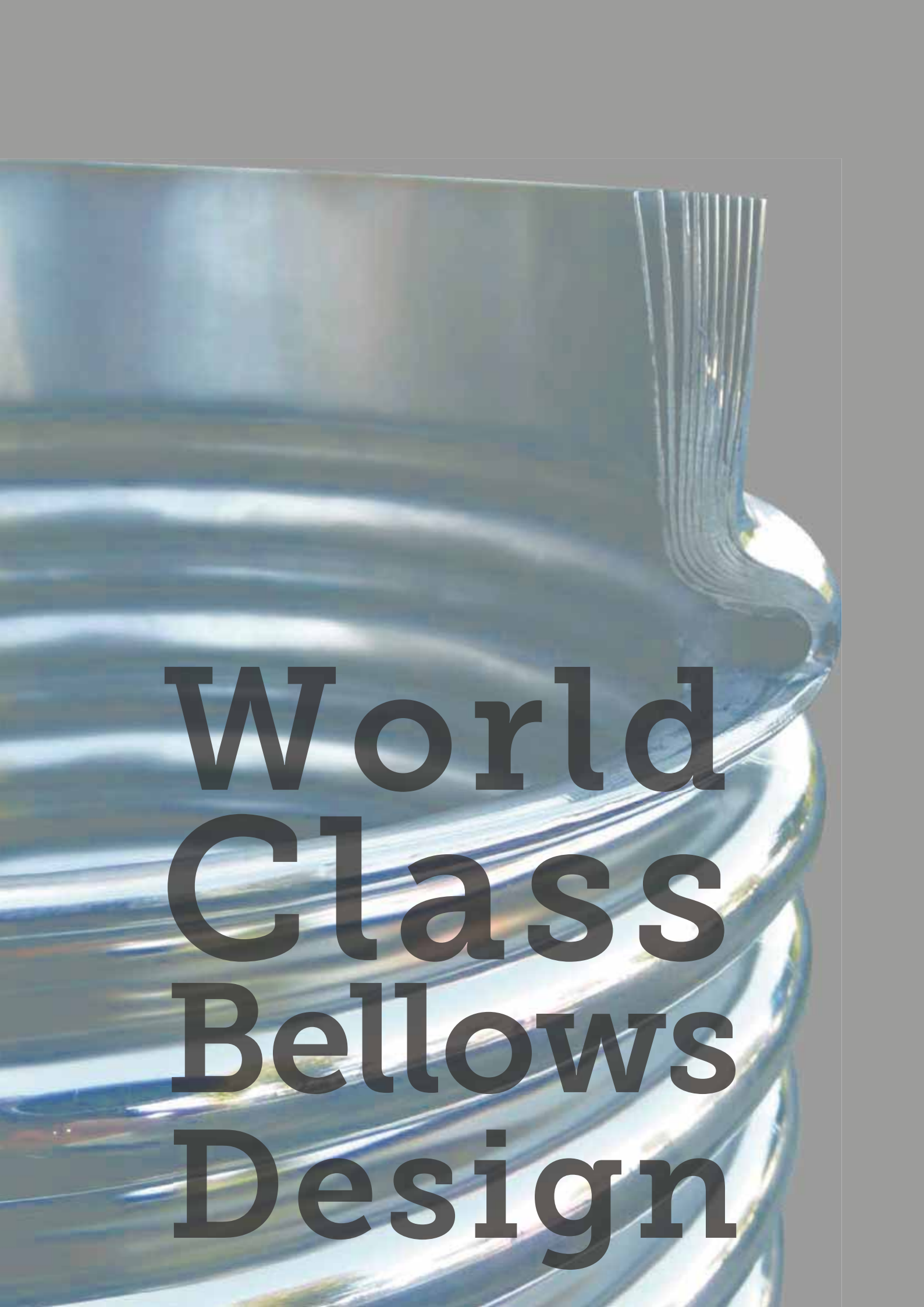




## ABOUT US

Founded in 2006 and having a successful history, KAYSE A.Ş. has become one of the leading brands in Turkey and has been taking firm steps forward to become a global leader in its field. With its specialized engineer staff, KAYSE A.Ş. is engaged in the production of stainless steel flexible hoses, metal expansion joints, rubber expansion joints, omega loop expansion joints, sprinkler connection hoses, and level, flow, and temperature gauges and commercial activities for special valves. As well as the sectors it serves, it continues to grow with its new investments. Behind the success of KAYSE A.Ş. is the customer-oriented and productivity-focused management approach. This approach has been developing not only with material gains but also with the awareness of corporate citizenship that the whole society benefits and will benefit from. Within the framework of this awareness, it carries out various corporate social responsibility and sponsorship projects focusing especially on education, environment, culture & arts, and sports.

KAYSE A.Ş., which is aware of its responsibilities in all areas it supports, acts with a vision for being a pioneer and a guide for the society and contributes to the national economy and employment with its investments. It offers superior technology, high quality and dynamic human resources for its customers. KAYSE A.Ş. aims at boosting brand value not only in Turkey but also in the regional and global scale. It reveals its vision of becoming a regional leader, especially in the production sector. KAYSE always offers its products based on the principles of customer satisfaction and trust. As a result of this, it represents Turkey in the whole world by creating a prestigious brand on a global scale. The synergies with large global companies also contribute considerably to this process. Being one of the pioneers of change in Turkey, KAYSE adapts quickly to the changes in the world as a result of all this experience and network. It makes the best use of its wide production, knowledge, and cooperation network. KAYSE A.Ş. acts with the aim of increasing its investments both in Turkey and abroad. In line with this aim, it exports its world-class products to 62 countries by getting their international certificates. With its young and dynamic structure and new generation management approach, KAYSE A.Ş. has established strong collaborations with its international partners and looks forward to the future with confidence.



**World  
Class  
Bellows  
Design**



# CONTENTS

CONTENTS	Page
Expansion Joints Types	01 – 02
Metal Bellows Expansion Joints	03 – 08
Metal Bellows Vibration Absorbers	09 – 10
Rubber Expansion Joints	11 – 12
Externally Pressurized Expansion Joints	13 – 16
Decorative Expansion Joints	17 – 18
Dilatation and Earthquake Expansion Joints	19 – 24
Dilatation Expansion Joints With Tie-Rods	25 – 30
Dilatation and Earthquake Expansion Joints (Galvanised)	31 – 34
Dilatation Expansion Joints With Tie-Rods (Galvanised)	35 – 38
Dilatation and Earthquake Expansion Joints (FM Approved)	39 – 44
Dilatation Expansion Joints With Tie-Rods (FM Approved)	45 – 50
Seismic Isolation Expansion Joints	51 – 56
U-Flex Omega Loop Expansion Joints	57 – 65
V-Flex Omega Loop Expansion Joints	66 – 74
PTFE (Teflon) Expansion Joints	75
Lens Type Expansion Joints	76
Rectangular Expansion Joints	77
Pressure Balanced Expansion Joints	78
Fabric Expansion Joints	79
Technical Informations & Calculations	82 – 101





## EXPANSION JOINTS

Dilatation expansion joints are interconnection elements that ensure uninterrupted and efficient operation of the installation by absorbing lateral deflections and stresses and breaks in the pipeline caused by building collapses or earthquakes at the dilatation connections of the buildings with different foundations. These types of expansion joints, which consist of double bellows, can be fixed to the desired expansion range by using limit rods. They can be used at all dilatation connections in the building. The range of movement prescribed in the system, the type of fluid in the pipeline, the place of use, the connection type, the operating pressure and temperature of the system must be specified while ordering.

## EXPANSION JOINTS TYPES

### 1- EXPANSION JOINTS TYPES ACCORDING TO THEIR DESIGN FORM

#### **Single Bellows Standard Type Expansion Joints**

They are used to absorb expansion in different directions that may occur in pipelines. They are commonly preferred for absorbing expansion in the axial direction (in the direction of the axis of the expansion joints).

#### **Externally Pressurized Expansion Joints**

Due to their special design, they are the preferred expansion joints types in lines where high pressure and expansion occur. In contrast to other types of expansion joints, the fluid passing through it has thrust on the outer surface, not on the inner surface of the bellows. Problems such as column instability (bending of the bellows and deviating from the axis) that may occur in the bellows at high expansions have been eliminated in externally pressurized expansion joints. Externally pressurized expansion joints are designed to absorb only axial movements.

#### **Universal Expansion Joints**

They are designed by connecting two separate bellows with a piece of pipe to absorb lateral or angular motion.

#### **Pressure Balanced Expansion Joints**

Pressure balanced expansion joints are capable of absorbing axial or lateral motion. An additional bellows is added to the body in such expansion joints, and it is subjected to pipeline pressure to produce a force equal to and opposite to that of the main bellows. Putting these bellows together neutralizes the pressure on the unit. These connections are usually made in case of direction changes in the piping, but in-line designs are also available.

#### **Gimbal Type Expansion Joints**

The gimbal type expansion joints are designed to be able to absorb motions that may occur in any plane. These expansion joints which are specially designed with hinges, ring, and pins can easily absorb the angular motions.



## Hinged Type Expansion Joints

The design of the hinged type expansion joints is similar to that of the Gimbal type expansion joints. However, Hinged type expansion joints can absorb angular motion in a single plane.

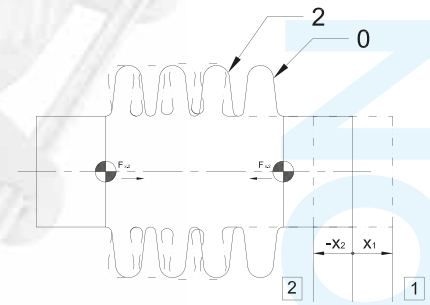
## Metal Vibration Absorber Expansion Joints

This type of type expansion joints is designed to absorb vibrations in pipe systems or equipment. Since the bellows section is designed as double-layered, it has a long service life.

## 2- EXPANSION JOINTS TYPES ACCORDING TO THEIR EXPANSION TYPES

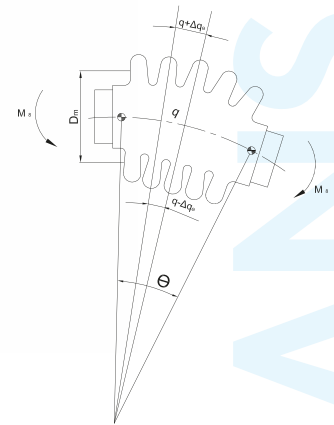
### Axial Expansion Joints

Axial expansion joints are designed to absorb elongation and contraction movements in the longitudinal direction in the pipelines. Axial type expansion joints can compensate for thermal expansion due to the fixation of a straight section of the pipeline between two points. The liner used in the axial expansion joints both ensures the flow to be laminar and increases the rotational speed of the expansion joint. The total motion, the type of fluid in the pipeline, the place of use, the connection type, the operating pressure and temperature of the system must be specified while ordering.



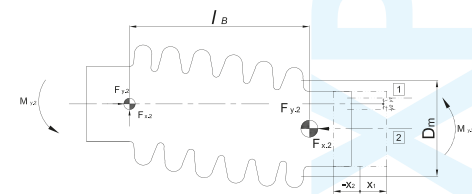
### Angular Expansion Joints

They are designed to absorb angular motions. These products are flexible connection elements that minimize the risk of break that may occur in the system as a result of motions such as earthquakes, and building collapses and ensure the continuity of the system by absorbing the stress on the rigid pipe. The total motion, the type of fluid in the pipeline, the place of use, the connection type, the operating pressure and temperature of the system must be specified while ordering.



### Lateral Expansion Joints

Lateral expansion joints are used to compensate for lateral deflections. They can absorb lateral motions in different directions. Also, they can absorb the pressure thrust by use of the joints or limit rods used in the design of the expansion joints.





Product Code	Definition
EMK30 - DF	Axial Metal Expansion Joints 30mm Expansion Rotary Flange
EMK30L - DF	Axial Metal Expansion Joints 30mm Expansion With Inner Sleeve Rotary Flange
EMK60 - DF	Axial Metal Expansion Joints 60mm Expansion Rotary Flange
EMK60L - DF	Axial Metal Expansion Joints 60mm Expansion With Inner Sleeve Rotary Flange

## GENERAL

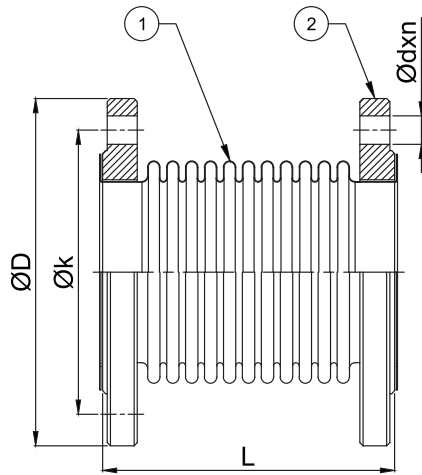
Axial expansion joints are designed to absorb expansion and compression movements in the longitudinal axial direction in the pipelines. Axial type expansion joints can absorb the vibrations in the pump, fan and pipe systems, and thermal expansions that will occur due to temperature difference by fixing a flat part of the pipeline between two points. Liner used in the axial expansion joints both ensures the flow to be laminar and increases the working life of the expansion joint. In the order phase, the total amount of motion, the type of fluid in the line, the location of use, the type of connection, the working pressure and the temperature of the system should be specified.



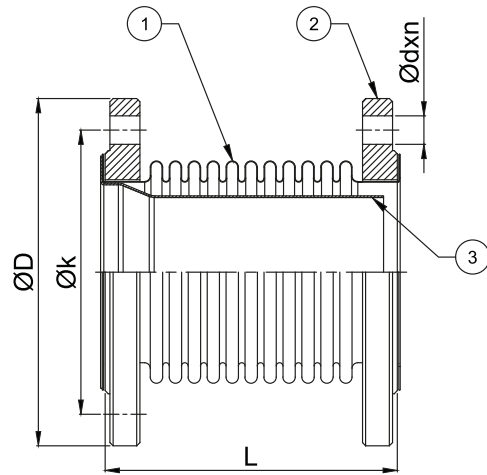
Standard Product Materials		Optional Product Materials
Bellows	1.4301 (AISI 304)	1.4541 / 1.4401 / Titanium / Incoloy 800H / Inconel etc.
Inner Sleeve	1.4301 (AISI 304)	1.4541 / 1.4401 / Titanium / Incoloy 800H / Inconel etc.
Flange	1.0038 (St 37-2)	Stainless Steel

Design Parameters	
Design Pressure	16 Bar (1 Bar...40 Bar Optional)
Design Temperature	+20 °C (-90°C...+550 °C Optional)
Diameters	DN25 (1")...DN2500 (100")
Movements	30mm (-20, +10) / 60mm (-40, +20)
Design Standards	EJMA, EN 14917
Certifications	TSE, CE - Module H (Optional) , EAC

\*\*Please contact our sales team for your special requests.



EMK...-DF



EMK...L-DF

Part Number	Specifications	
	Name	Material
1	Bellows	1.4301 (AISI 304)
2	Flange	1.0038 (S235JR / St37-2)
3	Inner Sleeve	1.4301 (AISI 304)

Diameters		LENGTH (L = mm)				ØD (mm)	Ø k (mm)	Ød x n (mm)	Effective Area (cm <sup>2</sup> )	Axial Spring Rate (N/mm)	
		EMK30-DF	EMK30L-DF	EMK60-DF	EMK60L-DF					X:30mm	X:60mm
		X:30mm	X:30mm	X:60mm	X:60mm						
DN25	1"	110		170	115	85	14*4	19,0	63,7	37,1	
DN32	1 1/4"	110		170	140	100	18*4	19,0	63,7	37,1	
DN40	1 1/2"	120		180	150	110	18*4	24,7	53,4	31,5	
DN50	2"	120		180	165	125	18*4	38,7	87,6	53,5	
DN65	2 1/2"	120		180	185	145	18*4	58,0	99,4	66,2	
DN80	3"	120		180	200	160	18*8	80,5	74,3	46,4	
DN100	4"	120		185	220	180	18*8	129,0	138,2	82,9	
DN125	5"	125		190	250	210	18*8	191,8	195,3	111,6	
DN150	6"	130		200	285	240	22*8	262,7	330,3	188,7	
DN200	8"	150		230	340	295	22*12	453,5	229,3	131,0	
DN250	10"	165		245	405	355	26*12	698,4	171,4	97,9	
DN300	12"	165		245	460	410	26*12	967,0	627,9	418,6	
DN350	14"	170		255	520	470	26*16	1149,6	807,1	448,4	
DN400	16"	170		255	580	525	30*16	1517,7	701,6	400,9	
DN450	18"	185		270	640	585	30*20	1884,2	836,0	477,7	
DN500	20"	195		285	715	650	33*20	2282,5	1043,5	695,7	

\*\* X value represents axial movement. Please contact our technical department for different movement requirements.  
\*\* Flange diameters are according to PN16 pressure class.



Product Code	Definition
EMK30 - SF	Axial Metal Expansion Joints 30mm Expansion Fixed Flange
EMK30L - SF	Axial Metal Expansion Joints 30mm Expansion With Inner Sleeve Fixed Flange
EMK60 - SF	Axial Metal Expansion Joints 60mm Expansion Fixed Flange
EMK60L - SF	Axial Metal Expansion Joints 60mm Expansion With Inner Sleeve Fixed Flange

## GENERAL

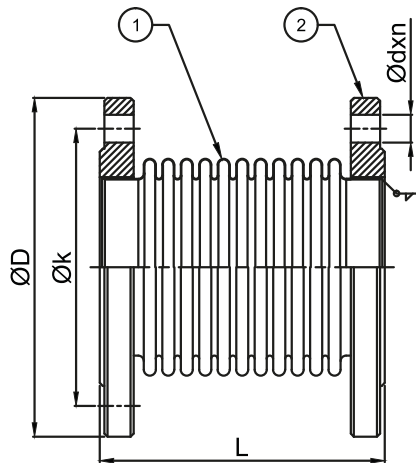
Axial expansion joints are designed to absorb expansion and compression movements in the longitudinal axial direction in the pipelines. Axial type expansion joints can absorb the vibrations in the pump, fan and pipe systems, and thermal expansions that will occur due to temperature difference by fixing a flat part of the pipeline between two points. Liner used in the axial expansion joints both ensures the flow to be laminar and increases the working life of the expansion joint. In the order phase, the total amount of motion, the type of fluid in the line, the location of use, the type of connection, the working pressure and the temperature of the system should be specified.



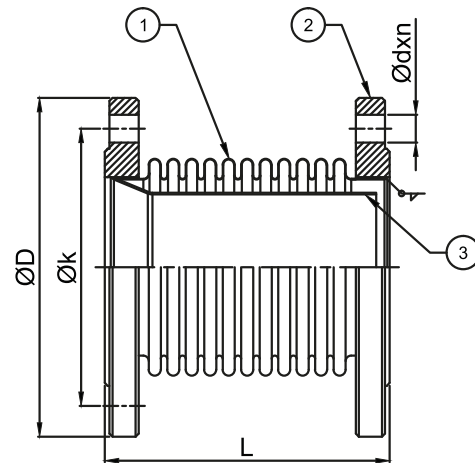
Standard Product Materials		Optional Product Materials
Bellows	1.4301 (AISI 304)	1.4541 / 1.4401 / Titanium / Incoloy 800H / Inconel etc.
Inner Sleeve	1.4301 (AISI 304)	1.4541 / 1.4401 / Titanium / Incoloy 800H / Inconel etc.
Flange	1.0038 (St 37-2 Galvaniz)	Stainless Steel

Design Parameters	
Design Pressure	16 Bar (1 Bar...40 Bar Optional)
Design Temperature	+20 °C (-90°C...+550 °C Optional)
Diameters	DN25 (1")...DN2500 (100")
Movements	30mm (-20, +10) / 60mm (-40, +20)
Design Standards	EJMA, EN 14917
Certifications	TSE, CE - Module H (Optional) , EAC

\*\*Please contact our sales team for your special requests.



EMK...-SF



EMK...L-SF

Part Number	Specifications	
	Name	Material
1	Bellows	1.4301 (AISI 304)
2	Flange	1.0038 (S235JR / St37-2)
3	Inner Sleeve	1.4301 (AISI 304)

Diameters		LENGTH (L = mm)				ØD (mm)	Øk (mm)	Ød x n (mm)	Effective Area (cm <sup>2</sup> )	Axial Spring Rate (N/mm)	
		EMK30-SF	EMK30L-SF	EMK60-SF	EMK60L-SF					X:30mm	X:60mm
		X:30mm	X:30mm	X:60mm	X:60mm						
DN25	1"	110		170	115	85	14*4	19,0	63,7	37,1	
DN32	1 1/4"	110		170	140	100	18*4	19,0	63,7	37,1	
DN40	1 1/2"	120		180	150	110	18*4	24,7	53,4	31,5	
DN50	2"	120		180	165	125	18*4	38,7	87,6	53,5	
DN65	2 1/2"	120		180	185	145	18*4	58,0	99,4	66,2	
DN80	3"	120		180	200	160	18*8	80,5	74,3	46,4	
DN100	4"	120		185	220	180	18*8	129,0	138,2	82,9	
DN125	5"	125		190	250	210	18*8	191,8	195,3	111,6	
DN150	6"	130		200	285	240	22*8	262,7	330,3	188,7	
DN200	8"	150		230	340	295	22*12	453,5	229,3	131,0	
DN250	10"	165		245	405	355	26*12	698,4	171,4	97,9	
DN300	12"	165		245	460	410	26*12	967,0	627,9	418,6	
DN350	14"	170		255	520	470	26*16	1149,6	807,1	448,4	
DN400	16"	170		255	580	525	30*16	1517,7	701,6	400,9	
DN450	18"	185		270	640	585	30*20	1884,2	836,0	477,7	
DN500	20"	195		285	715	650	33*20	2282,5	1043,5	695,7	

\*\* X value represents axial movement. Please contact our technical department for different movement requirements.

\*\*Flange diameters are according to PN16 pressure class.



Product Code	Definition
EMK30 - KB	Axial Metal Expansion Joints 30mm Expansion Welding Ends
EMK30L - KB	Axial Metal Expansion Joints 30mm Expansion With Inner Sleeve Welding Ends
EMK60 - KB	Axial Metal Expansion Joints 60mm Expansion Welding Ends
EMK60L - KB	Axial Metal Expansion Joints 60mm Expansion With Inner Sleeve Welding Ends

## GENERAL

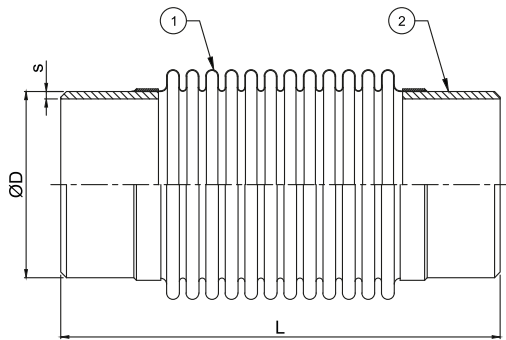
Axial expansion joints are designed to absorb expansion and compression movements in the longitudinal axial direction in the pipelines. Axial type expansion joints can absorb the vibrations in the pump, fan and pipe systems, and thermal expansions that will occur due to temperature difference by fixing a flat part of the pipeline between two points. Liner used in the axial expansion joints both ensures the flow to be laminar and increases the working life of the expansion joint. In the order phase, the total amount of motion, the type of fluid in the line, the location of use, the type of connection, the working pressure and the temperature of the system should be specified.



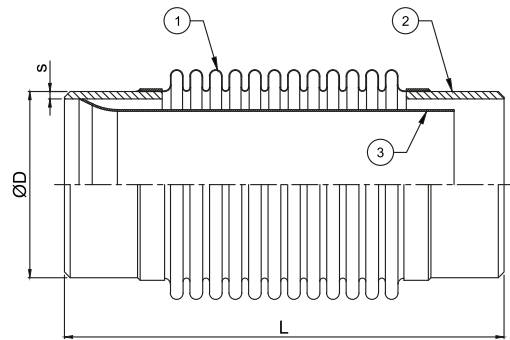
Standard Product Materials		Optional Product Materials
Bellows	1.4301 (AISI 304)	1.4541 / 1.4401 / Titanium / Incoloy 800H / Inconel etc.
Inner Sleeve	1.4301 (AISI 304)	1.4541 / 1.4401 / Titanium / Incoloy 800H / Inconel etc.
Welding Ends	1.0038 (St 37-2)	Stainless Steel

Design Parameters	
Design Pressure	16 Bar (1 Bar...40 Bar Optional)
Design Temperature	+20 °C (-90°C...+550 °C Optional)
Diameters	DN25 (1")...DN2500 (100")
Movements	30mm (-20, +10) / 60mm (-40, +20)
Design Standards	EJMA, EN 14917
Certifications	TSE, CE - Module H (Optional) , EAC

\*\*Please contact our sales team for your special requests.



EMK...-KB



EMK...L-KB

Part Number	Specifications	
	Name	Material
1	Bellows	1.4301 (AISI 304)
2	Welding Ends	1.0038 (S235JR / St37-2)
3	Inner Sleeve	1.4301 (AISI 304)

Diameters		LENGTH (L = mm)				ØD (mm)	s (mm)	Effective Area (cm <sup>2</sup> )	Axial Spring Rate (N/mm)	
		EMK30-KB	EMK30L-KB	EMK60-KB	EMK60L-KB				X: 30mm	X: 60mm
		X: 30mm	X: 30mm	X: 60mm	X: 60mm					
DN25	1"	180		230	33,7	3,2	19,0	63,7	37,1	
DN32	1 1/4"	180		240	42,4	3,2	19,0	63,7	37,1	
DN40	1 1/2"	190		240	48,3	3,2	24,7	53,4	31,5	
DN50	2"	190		240	60,3	3,6	38,7	87,6	53,5	
DN65	2 1/2"	190		240	76,1	3,6	58,0	99,4	66,2	
DN80	3"	190		250	88,9	4	80,5	74,3	46,4	
DN100	4"	200		270	114,3	4,5	129,0	138,2	82,9	
DN125	5"	200		270	139,7	5	191,8	195,3	111,6	
DN150	6"	250		320	165,1	5	262,7	330,3	188,7	
DN200	8"	270		340	219,1	6,3	453,5	229,3	131,0	
DN250	10"	310		395	273	6,3	698,4	171,4	97,9	
DN300	12"	310		395	323,9	7,1	967,0	627,9	418,6	
DN350	14"	320		405	355,6	8	1149,6	807,1	448,4	
DN400	16"	320		405	406,4	8	1517,7	701,6	400,9	
DN450	18"	330		420	457	8	1884,2	836,0	477,7	
DN500	20"	340		430	508	8	2282,5	1043,5	695,7	

\*\* X value represents axial movement. Please contact our technical department for different movement requirements.



Product Code	Definition
EMK30 - LR	Metal Bellows Vibration Absorber With Tie-Rods Double Layered

## GENERAL

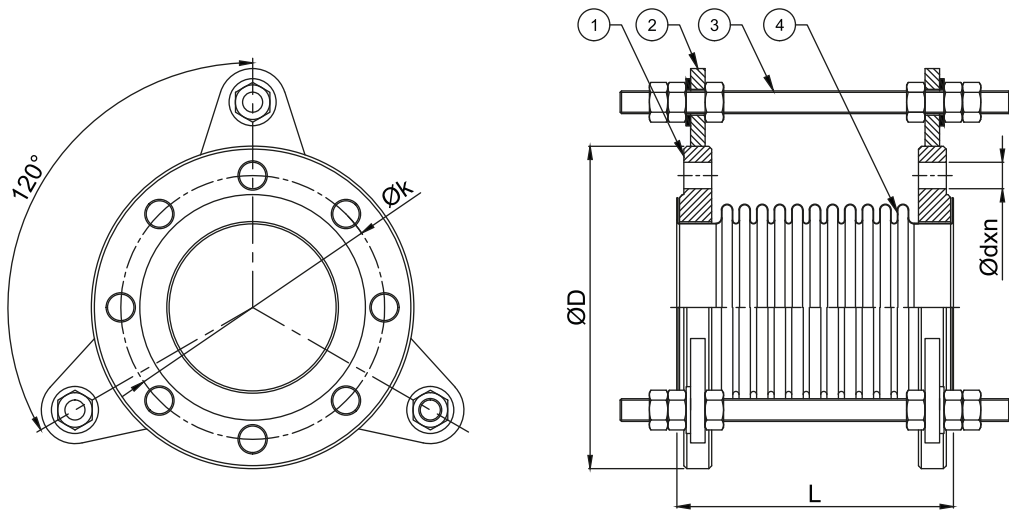
Axial expansion joints are used to solve problems caused by vibration in the system with double-deck stainless bellows structure as well as to compensate for thermal expansions. They are very effective in particular, in the reduction of stress in the system, in absorbing sound and vibration in the connections of devices such as pumps and compressors. Its special design increases the life of the devices and armatures used in the system.



Standard Product Materials		Optional Product Materials
Bellows	1.4301 (AISI 304)	1.4541 / 1.4401 / Titanium / Incoloy 800H / Inconel etc.
Tie-Rod Holders	1.0038 (St 37-2)	Stainless Steel
Flanges	1.0038 (St 37-2)	Stainless Steel

Design Parameters	
Design Pressure	16 Bar (1 Bar...40 Bar)
Design Temperature	+20 °C (-90°C...+550°C)
Diameters	DN25 (1")...DN2500 (100")
Movements	30mm (-20, +10)
Design Standards	EJMA, EN 14917
Certifications	TSE, CE - Module H (Optional) - EAC

\*\*Please contact our sales team for your special requests.



Part Number	Specifications	
	Name	Material
1	Flange	1.0038 (S235JR / St37-2)
2	Tie-Rod Holders	1.0038 (S235JR / St37-2)
3	Tie-Rods	1.0038 (S235JR / St37-2)
4	Bellows	1.4301 (AISI 304)

Diameters		EMK30-LR	ØD (mm)	Øk (mm)	Ødxn
		LENGTH (L = mm)			
DN25	1"	110	115	85	14*4
DN32	1 1/4"	110	140	100	18*4
DN40	1 1/2"	120	150	110	18*4
DN50	2"	120	165	125	18*4
DN65	2 1/2"	120	185	145	18*4
DN80	3"	120	200	160	18*8
DN100	4"	120	220	180	18*8
DN125	5"	125	250	210	18*8
DN150	6"	130	285	240	22*8
DN200	8"	150	340	295	22*12
DN250	10"	165	405	355	26*12
DN300	12"	165	460	410	26*12

\*\* Flange diameters are according to PN16 pressure class.  
 \*\* Number of Tie-Rods quantity can be changed according to diameter.

Product Code	Definition
KK10 - EPDM	Rubber Expansion Joint EPDM Rubber / Ductile Iron Casting Flanged
KK20 - EPDM	Rubber Expansion Joint EPDM Rubber / Carbon Steel Flanged
KK10 - NBR	Rubber Expansion Joint NBR Rubber / Ductile Iron Casting Flanged
KK20 - NBR	Rubber Expansion Joint NBR Rubber / Carbon Steel Flanged

## GENERAL

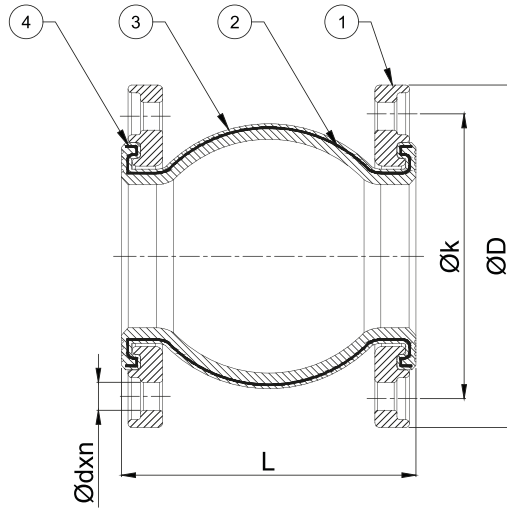
Rubber expansion joints are elastic and high strength parts that absorb vibration and noise in systems. They are indispensable elements of pressure or vacuum systems. Due to the elasticity of rubber based materials, they absorb high noise and vibration in all directions. Since their flanges are rotary type, they are easy to install. Due to its special design, it is not necessary to use gasket during its installation. Expansion joint strength and vibration damping capability increase thanks to special steel courts inside the rubber material. They are widely used in ventilation and air conditioning lines, shipbuilding industry, pumps inlets and outlets, waste water and sewage systems.



Standard Product Materials		Optional Product Materials
Bellows	EPDM	NBR, Neopren
Rubber Reinforcement	Steel Wire Cord Fabric	-
Flangelar	GGG 40.3 (Ductile Iron Casting)	1.0038, Stainless Steel

Design Parameters	
Design Pressure (Max.)	10 Bar
Design Temperature (Max.)	+20 °C (Max. 100 °C)
Diameters	DN32 (1 1/4")...DN700 (28")

\*\*Please contact our sales team for your special requests.



Part Number	Specifications	
	Name	Material
1	Flange	GGG-40.3 (Ductile Iron Casting)
2	Rubber Reinforcement	Cord Fabric
3	Rubber Bellows	EPDM/ NBR
4	Steel Ring	-

Diameters		KK10-EPDM	KK20-EPDM	KK10-NBR	KK20-NBR	ØD (mm)	Øk (mm)	Ød x n (mm)
		LENGTH(L=mm)	LENGTH(L=mm)	LENGTH(L=mm)	LENGTH(L=mm)			
DN32	1 1/4"	100	100	100	100	140	100	18*4
DN40	1 1/2"	<b>100</b> , 130, 150	<b>100</b> , 130, 150	<b>100</b> , 130, 150	<b>100</b> , 130, 150	150	110	18*4
DN50	2"	<b>100</b> , 130, 150	<b>100</b> , 130, 150	<b>100</b> , 130, 150	<b>100</b> , 130, 150	165	125	18*4
DN65	2 1/2"	<b>100</b> , 130, 150	<b>100</b> , 130, 150	<b>100</b> , 130, 150	<b>100</b> , 130, 150	185	145	18*4
DN80	3"	<b>100</b> , 130, 150	<b>100</b> , 130, 150	<b>100</b> , 130, 150	<b>100</b> , 130, 150	200	160	18*8
DN100	4"	<b>100</b> , 130, 150	<b>100</b> , 130, 150	<b>100</b> , 130, 150	<b>100</b> , 130, 150	220	180	18*8
DN125	5"	<b>120</b> , 130, 150 160, 175	<b>120</b> , 130, 150 160, 175	<b>120</b> , 130, 150 160, 175	<b>120</b> , 130, 150 160, 175	250	210	18*8
DN150	6"	<b>120</b> , 130 150, 160	<b>120</b> , 130 150, 160	<b>120</b> , 130 150, 160	<b>120</b> , 130 150, 160	285	240	22*8
DN200	8"	<b>120</b> , 130 150, 175	<b>120</b> , 130 150, 175	<b>120</b> , 130 150, 175	<b>120</b> , 130 150, 175	340	295	22*12
DN250	10"	100, <b>130</b> 175, 250	100, <b>130</b> 175, 250	100, <b>130</b> 175, 250	100, <b>130</b> 175, 250	405	355	26*12
DN300	12"	100, <b>130</b> , 190 210, 250, 260	100, <b>130</b> , 190 210, 250, 260	100, <b>130</b> , 190 210, 250, 260	100, <b>130</b> , 190 210, 250, 260	460	410	26*12
DN350	14"	160, 210 235, 260	160, 210 235, 260	160, 210 235, 260	160, 210 235, 260	520	470	26*16
DN400	16"	220, 235, 240	220, 235, 240	220, 235, 240	220, 235, 240	580	525	30*16
DN450	18"	220, 250	220, 250	220, 250	220, 250	640	585	30*20
DN500	20"	100, 200, 270	100, 200, 270	100, 200, 270	100, 200, 270	715	650	33*20
DN600	24"	260, 300	260, 300	260, 300	260, 300	840	770	36*20
DN700	28"	275, 300	275, 300	275, 300	275, 300	910	840	36*24

\*\*Flange diameters are according to PN16 pressure class.

\*\*Written in bold punto lengths are present stock products.



Product Code	Definition
DB30 - F	Externally Pressurised Expansion Joints Flanged Axial 30mm Expansion
DB60 - F	Externally Pressurised Expansion Joints Flanged Axial 60mm Expansion
DB90 - F	Externally Pressurised Expansion Joints Flanged Axial 90mm Expansion
DB120 - F	Externally Pressurised Expansion Joints Flanged Axial 120mm Expansion

## GENERAL

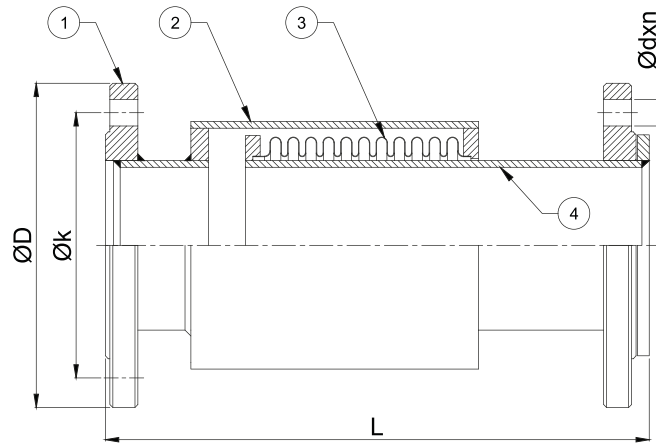
External pressurized axial metal expansion joints are specially designed for use in pipe systems where high amounts of axial compression and elongation occur. Due to the structure of the external pressurized axial metal expansion joints, the flow and pressure of the media is given to the outer surface of the bellows. Outer pressurization of the bellows eliminates pressure instabilities and allows the absorption of large amounts of axial expansion. In this way, the amount of expansion joint used in the system is minimized.



Standard Product Materials		Optional Product Materials
Bellows	1.4301 (AISI 304)	1.4541 / 1.4401 / Titanium / Incoloy 800H / Inconel etc.
Inside / Outside Pipe	1.0038 (St 37-2)	Stainless Steel
Flange	1.0038 (St 37-2)	Stainless Steel

Design Parameters	
Design Pressure	16 Bar (1 Bar...64 Bar Optional)
Design Temperature	+20 °C (-90°C...+550 °C Optional)
Diameters	DN25 (1")...DN2500 (100")
Movements	30mm (-20, +10) / 60mm (-40, +20) / 90mm (-70, +20) / 120mm (-90, +30)
Design Standards	EJMA, EN 14917
Certifications	TSE, CE - Module H (Optional) - EAC

\*\*Please contact our sales team for your special requests.



Part Number	Specifications	
	Name	Material
1	Flange	1.0038 (S235JR / St37-2)
2	Outside Pipe	1.0038 (S235JR / St37-2)
3	Bellows	1.4301 (AISI 304)
4	Inside Pipe	1.0038 (S235JR / St37-2)

Diameters		LENGTH (L = mm)				ØD (mm)	Øk (mm)	Ød x n (mm)	Effective Area (cm <sup>2</sup> )	Axial Spring Rate (N/mm)			
		DB30-F	DB60-F	DB90-F	DB120-F					X:30mm	X:60mm	X:90mm	X:120mm
		X:30mm	X:60mm	X:90mm	X:120mm								
DN25	1"	315	415	510	550	115	85	14*4	19,0	183,0	122,0	97,6	86,1
DN32	1 1/4"	325	425	520	550	140	100	18*4	19,0	183,0	122,0	97,6	86,1
DN40	1 1/2"	335	435	535	550	150	110	18*4	24,7	146,5	102,6	73,2	60,3
DN50	2"	340	460	540	560	165	125	18*4	38,7	132,2	80,8	66,1	51,9
DN65	2 1/2"	355	460	555	570	185	145	18*4	58,0	361,8	221,2	165,8	61,3
DN80	3"	355	465	570	590	200	160	18*8	80,5	220,8	138,0	92,0	73,6
DN100	4"	360	465	600	620	220	180	18*8	129,0	233,7	133,5	85,0	66,7
DN125	5"	375	485	600	620	250	210	18*8	191,8	166,2	95,0	66,5	51,1
DN150	6"	385	500	625	645	285	240	22*8	262,7	289,2	165,2	110,1	96,4
DN200	8"	435	560	700	720	340	295	22*12	453,5	157,8	97,1	63,1	60,1
DN250	10"	460	600	750	770	405	355	26*12	698,4	151,7	75,8	50,5	39,9
DN300	12"	350	460	540	670	460	410	26*12	967,0	297,4	185,9	123,9	92,9
DN350	14"	430	530	705	780	520	470	26*16	1149,6	405,4	231,7	147,4	114,8
DN400	16"	455	555	730	805	580	525	30*16	1517,7	356,5	178,2	118,8	89,1
DN450	18"	480	580	755	830	640	585	30*20	1884,2	414,2	207,1	138,0	103,5
DN500	20"	505	605	780	855	715	650	33*20	2282,5	522,4	313,4	195,9	156,7

\*\* X value represents axial movement. Please contact our technical department for different movement requirements.  
\*\* Flange diameters are according to PN16 pressure class.

Product Code	Definition
DB30 - KB	Externally Pressurised Expansion Joint Welding Ends Axial 30mm Expansion
DB60 - KB	Externally Pressurised Expansion Joint Welding Ends Axial 60mm Expansion
DB90 - KB	Externally Pressurised Expansion Joint Welding Ends Axial 90mm Expansion
DB120 - KB	Externally Pressurised Expansion Joint Welding Ends Axial 120mm Expansion

**GENERAL**

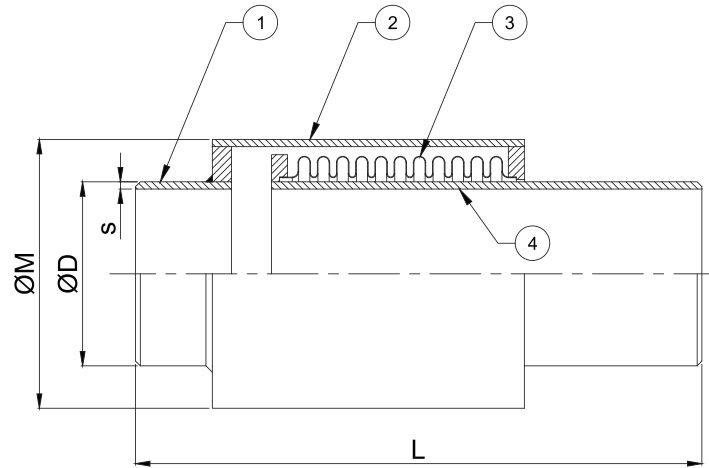
External pressurized axial metal expansion joints are specially designed for use in pipe systems where high amounts of axial compression and elongation occur. Due to the structure of the external pressurized axial metal expansion joints, the flow and pressure of the media is given to the outer surface of the bellows. Outer pressurization of the bellows eliminates pressure instabilities and allows the absorption of large amounts of axial expansion. In this way, the amount of expansion joint used in the system is minimized.



Standard Product Materials		Optional Product Materials
Bellows	1.4301 (AISI 304)	1.4541 / 1.4401 / Titanium / Incoloy 800H / Inconel etc.
Inside / Outside Pipe	1.0038 (St 37-2)	Stainless Steel
Welding Ends	1.0038 (St 37-2)	Stainless Steel

Design Parameters	
Design Pressure	16 Bar (1 Bar...64 Bar Optional)
Design Temperature	+20 °C (-90°C...+550 °C Optional)
Diameters	DN25 (1")...DN2500 (100")
Movements	30mm (-20, +10) / 60mm (-40, +20) / 90mm (-70, +20) / 120mm (-90, +30)
Design Standards	EJMA, EN 14917
Certifications	TSE, CE - Module H (Optional) - EAC

\*\*Please contact our sales team for your special requests.



Part Number	Specifications	
	Name	Material
1	Welding Ends	1.0038 (S235JR / St37-2)
2	Outside Pipe	1.0038 (S235JR / St37-2)
3	Bellows	1.4301 (AISI 304)
4	Inside Pipe	1.0038 (S235JR / St37-2)

Diameters	LENGTH (L = mm)				ØD (mm)	s (mm)	ØM (mm)	Effective Area (cm <sup>2</sup> )	Axial Spring Rate (N/mm)				
	DB30-KB	DB60-KB	DB90-KB	DB120-KB					X:30mm	X:60mm	X:90mm	X:120mm	
	X:30mm	X:60mm	X:90mm	X:120mm									
DN25	1"	295	395	490	530	33,7	3,2	88,9	19,0	183,0	122,0	97,6	86,1
DN32	1 1/4"	305	405	500	530	42,4	3,2	88,9	19,0	183,0	122,0	97,6	86,1
DN40	1 1/2"	315	415	515	530	48,3	3,2	88,9	24,7	146,5	102,6	73,2	60,3
DN50	2"	320	440	520	540	60,3	3,6	88,9	38,7	132,2	80,8	66,1	51,9
DN65	2 1/2"	335	440	535	550	76,1	3,6	114,3	58,0	361,8	221,2	165,8	61,3
DN80	3"	335	445	550	570	88,9	4	139,7	80,5	220,8	138,0	92,0	73,6
DN100	4"	340	445	580	600	114,3	4,5	165	129,0	233,7	133,5	85,0	66,7
DN125	5"	355	465	580	600	139,7	5	219,1	191,8	166,2	95,0	66,5	51,1
DN150	6"	365	480	605	625	165,1	5	273	262,7	289,2	165,2	110,1	96,4
DN200	8"	415	540	680	700	219,1	6,3	323,9	453,5	157,8	97,1	63,1	60,1
DN250	10"	440	580	730	750	273	6,3	387	698,4	151,7	75,8	50,5	39,9
DN300	12"	330	440	520	650	323,9	7,1	420	967,0	297,4	185,9	123,9	92,9
DN350	14"	400	500	675	750	355,6	8	455	1149,6	405,4	231,7	147,4	114,8
DN400	16"	425	525	700	775	406,4	8	525	1517,7	356,5	178,2	118,8	89,1
DN450	18"	450	550	725	800	457	8	580	1884,2	414,2	207,1	138,0	103,5
DN500	20"	475	575	750	825	508	8	635	2282,5	522,4	313,4	195,9	156,7

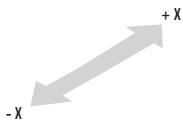
\*\* X value represents axial movement. Please contact our technical department for different movement requirements.



Product Code	Definition
BK50 - D	Decorative Type Expansion Joint Threaded Axial $\pm 25$ mm Expansion
BK50 - KB	Decorative Type Expansion Joint Welding Ends Axial $\pm 25$ mm Expansion

## GENERAL

Pipe expansion joints are expansion parts which can absorb expansion, vibration and noise in axial direction. Expansion and compression due to temperature differences in the column lines of high-rise buildings and the resulting bends, noises are absorbed by decorative type pipe expansion joints. These expansion joints, which are required to be used in the column lines of buildings higher than 6-7 floors, should be used in a maximum of 30 meters (10 floors). Decorative type expansion joints can be used in residences, hotels and visible spaces with their aesthetic appearance. The inner shell prevents pressure losses and misalignments, while the outer shell protects the expansion joint against external influences.



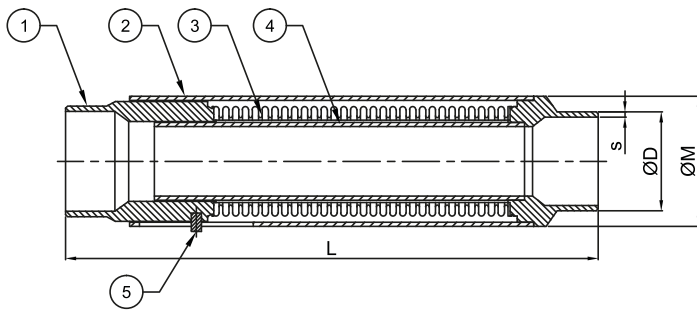
### Standard Product Materials

Bellows	1.4301 (AISI 304)
Inside / Outside Pipe	1.0038 (St 37-2)
Connection	1.0038 (St 37-2)

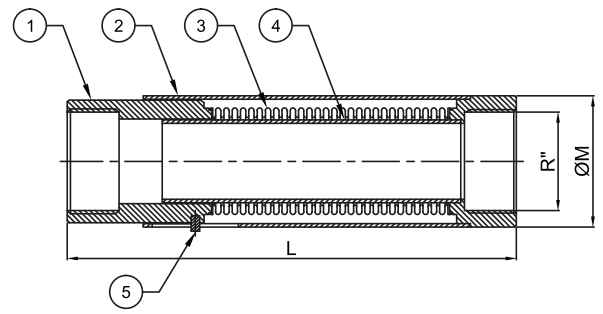
### Design Parameters

Design Pressure	16 Bar
Design Temperature	+20 °C (Up to +100°C)
Diameters	DN25 (1")...DN100 (4")
Movements	50mm (-25, +25)
Design Standards	EJMA
Certifications	TSE

\*\*Please contact our sales team for your special requests.



BK50-KB



BK50-D

Part Number	Specifications	
	Name	Material
1	Connection (Welding Ends / Threaded)	1.0038 (S235JR / St37-2)
2	Outside Pipe	1.0038 (S235JR / St37-2)
3	Bellows	1.4301 (AISI 304)
4	Inside Pipe	1.0038 (S235JR / St37-2)
5	Limit Pin	1.0038 (S235JR / St37-2)

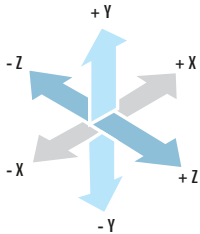
Diameters	LENGTH (L = mm)	Ø M (mm)
	BK50-D	
R 1"	260	48,3
R 1 1/4"	260	51
R 1 1/2"	260	60,5
R 2"	260	76

Diameters	LENGTH (L = mm)	Ø D (mm)	s (mm)	Ø M (mm)
	BK50-KB			
DN25	260	33,7	3,2	48,3
DN32	260	42,4	3,2	51
DN40	260	48,3	3,2	60,5
DN 50	260	60,3	3,6	76
DN 65	260	76,1	3,6	88,9
DN 80	260	88,9	4	114,3
DN 100	260	114,3	4,5	139,7

Product Code	Definition
KM100 - F	Dilatation & Earthquake Expansion Joint Flanged $\pm 50$ mm Expansion
KM200 - F	Dilatation & Earthquake Expansion Joint Flanged $\pm 100$ mm Expansion
KM300 - F	Dilatation & Earthquake Expansion Joint Flanged $\pm 150$ mm Expansion
KM400 - F	Dilatation & Earthquake Expansion Joint Flanged $\pm 200$ mm Expansion

**GENERAL**

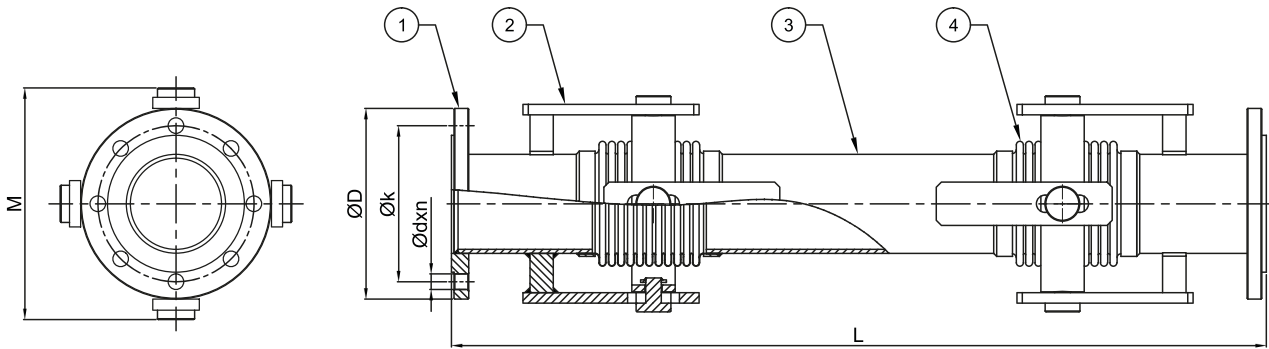
Dilatation & Earthquake expansion joints are the flexible connection elements that minimize the risk of breakage that may occur in the system as a result of seismic (earthquake, building collapses, etc.) movements by damping the three dimensional movement as axial, lateral and angular and provide the continuity of the system by removing the stress on the rigid pipe. The Dilatation & Earthquake Expansion joints, which are designed to meet the movement in three different directions (axial, lateral and angular) are widely used in HVAC piping systems. They can also be used in places such as all building passages, Dilatation points etc.



Standard Product Materials		Optional Product Materials
Bellows	1.4301 (AISI 304)	1.4541 / 1.4401 / Titanium / Incoloy 800H / Inconel etc.
Joint Arms	1.0038 (St 37-2)	Stainless Steel
Flanges	1.0038 (St 37-2)	Stainless Steel
Intermediate Pipe	1.0038 (St 37-2)	Stainless Steel

Design Parameters	
Design Pressure	16 Bar (1 Bar...64 Bar)
Design Temperature	+20 °C (-90°C...+550°C)
Diameters	DN25 (1")...DN2500 (100")
Movements	X: $\pm 50$ mm, Y,Z: $\pm 50$ mm / Y,Z: $\pm 100$ mm / Y,Z: $\pm 150$ mm / Y,Z: $\pm 200$ mm
Design Standards	EJMA, EN 14917
Certifications	TSE, CE - Module H (Optional) - EAC

\*\*Please contact our sales team for your special requests.



Part Number	Specifications	
	Name	Material
1	Flange	1.0038 (S235JR / St37-2)
2	Joint Arm	1.0038 (S235JR / St37-2)
3	Intermediate Pipe	1.0038 (S235JR / St37-2)
4	Bellows	1.4301 (AISI 304)

Diameters		LENGTH (L = mm)				ØD (mm)	Øk (mm)	Ødxn (mm)	M (mm)	Effective Area (cm <sup>2</sup> )
		KM100-F	KM200-F	KM300-F	KM400-F					
		X: ±50mm Y: ±50mm Z: ±50mm	X: ±50mm Y: ±100mm Z: ±100mm	X: ±50mm Y: ±150mm Z: ±150mm	X: ±50mm Y: ±200mm Z: ±200mm					
DN25	1"	730	930	1130	1330	115	85	14*4	170	19,0
DN32	1 1/4"	730	930	1130	1330	140	100	18*4	170	19,0
DN40	1 1/2"	730	930	1130	1330	150	110	18*4	170	24,7
DN50	2"	790	990	1190	1400	165	125	18*4	195	38,7
DN65	2 1/2"	790	990	1240	1500	185	145	18*4	210	58,0
DN80	3"	840	1040	1270	1500	200	160	18*8	220	80,5
DN100	4"	840	1040	1300	1550	220	180	18*8	265	129,0
DN125	5"	970	1170	1480	1770	250	210	18*8	310	191,8
DN150	6"	970	1170	1480	1770	285	240	22*8	335	262,7
DN200	8"	1140	1360	1710	2060	340	295	22*12	425	453,5
DN250	10"	1140	1360	1710	2060	405	355	26*12	470	698,4
DN300	12"	1110	1460	1860	2250	460	410	26*12	570	967,0
DN350	14"	1220	1530	1930	2330	520	470	26*16	620	1149,6
DN400	16"	1270	1650	2100	2550	580	525	30*16	700	1517,7
DN450	18"	1335	1800	2350	2875	640	585	30*20	745	1884,2
DN500	20"	1370	1950	2550	3200	715	650	33*20	815	2282,5

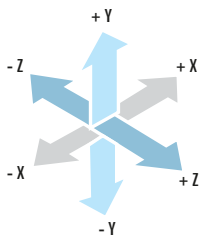
\*\* X,Y,Z value represents axial, lateral, angular movements. Please contact our technical department for different movement requirements.  
\*\* Flange diameters are according to PN16 pressure class.



Product Code	Definition
KM100 - KB	Dilatation & Earthquake Expansion Joint Welding Ends ±50mm Expansion
KM200 - KB	Dilatation & Earthquake Expansion Joint Welding Ends ±100mm Expansion
KM300 - KB	Dilatation & Earthquake Expansion Joint Welding Ends ±150mm Expansion
KM400 - KB	Dilatation & Earthquake Expansion Joint Welding Ends ±200mm Expansion

**GENERAL**

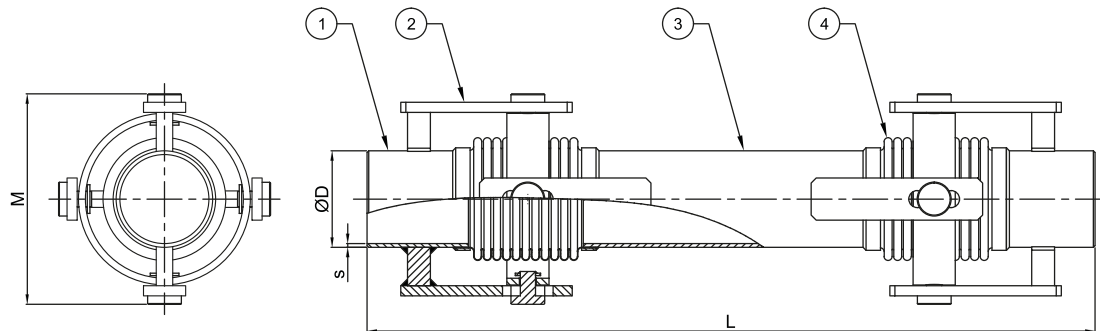
Dilatation & Earthquake expansion joints are the flexible connection elements that minimize the risk of breakage that may occur in the system as a result of seismic (earthquake, building collapses, etc.) movements by damping the three dimensional movement as axial, lateral and angular and provide the continuity of the system by removing the stress on the rigid pipe. The Dilatation & Earthquake Expansion joints, which are designed to meet the movement in three different directions (axial, lateral and angular) are widely used in HVAC piping systems. They can also be used in places such as all building passages, Dilatation points etc.



Standard Product Materials		Optional Product Materials
Bellows	1.4301 (AISI 304)	1.4541 / 1.4401 / Titanium / Incoloy 800H / Inconel etc.
Joint Arms	1.0038 (St 37-2)	Stainless Steel
Welding Ends	1.0038 (St 37-2)	Stainless Steel
Intermediate Pipe	1.0038 (St 37-2)	Stainless Steel

Design Parameters	
Design Pressure	16 Bar (1 Bar...64 Bar)
Design Temperature	+20 °C (-90°C...+550°C)
Diameters	DN25 (1")...DN2500 (100")
Movements	X:±50mm, Y,Z:±50mm / Y,Z:±100mm / Y,Z:±150mm / Y,Z:±200mm
Design Standards	EJMA, EN 14917
Certifications	TSE, CE - Module H (Optional) - EAC

\*\*Please contact our sales team for your special requests.



Part Number	Specifications	
	Name	Material
1	Welding Ends	1.0038 (S235JR / St37-2)
2	Joint Arm	1.0038 (S235JR / St37-2)
3	Intermediate Pipe	1.0038 (S235JR / St37-2)
4	Bellows	1.4301 (AISI 304)

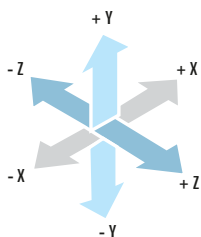
Diameters		LENGTH (L = mm)				ØD (mm)	s (mm)	M (mm)	Effective Area (cm <sup>2</sup> )
		KM100-KB	KM200-KB	KM300-KB	KM400-KB				
		X: ±50mm Y: ±50mm Z: ±50mm	X: ±50mm Y: ±100mm Z: ±100mm	X: ±50mm Y: ±150mm Z: ±150mm	X: ±50mm Y: ±200mm Z: ±200mm				
DN25	1"	710	910	1110	1310	33,7	3,2	170	19,0
DN32	1 1/4"	710	910	1110	1310	42,4	3,2	170	19,0
DN40	1 1/2"	710	910	1110	1310	48,3	3,2	170	24,7
DN50	2"	770	970	1170	1380	60,3	3,6	195	38,7
DN65	2 1/2"	770	970	1220	1480	76,1	3,6	210	58,0
DN80	3"	820	1020	1250	1480	88,9	4	220	80,5
DN100	4"	820	1020	1280	1530	114,3	4,5	265	129,0
DN125	5"	950	1150	1460	1750	139,7	5	310	191,8
DN150	6"	950	1150	1460	1750	165,1	5	335	262,7
DN200	8"	1120	1340	1690	2040	219,1	6,3	425	453,5
DN250	10"	1120	1340	1690	2040	273	6,3	470	698,4
DN300	12"	1080	1430	1830	2230	323,9	7,1	570	967,0
DN350	14"	1190	1500	1900	2300	355,6	8	620	1149,6
DN400	16"	1240	1620	2070	2520	406,4	8	700	1517,7
DN450	18"	1305	1770	2320	2845	457	8	745	1884,2
DN500	20"	1340	1920	2520	3170	508	8	815	2282,5

\*\* X,Y,Z value represents axial, lateral, angular movements. Please contact our technical department for different movement requirements.

Product Code	Definition
KM100 - YV	Dilatation & Earthquake Expansion Joint Grooved $\pm 50$ mm Expansion
KM200 - YV	Dilatation & Earthquake Expansion Joint Grooved $\pm 100$ mm Expansion
KM300 - YV	Dilatation & Earthquake Expansion Joint Grooved $\pm 150$ mm Expansion
KM400 - YV	Dilatation & Earthquake Expansion Joint Grooved $\pm 200$ mm Expansion

## GENERAL

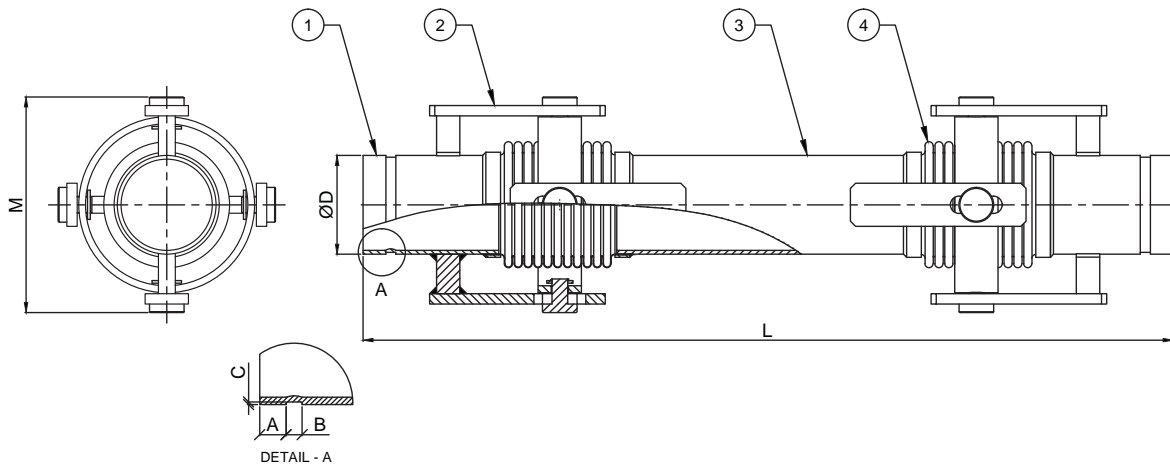
Dilatation & Earthquake expansion joints are the flexible connection elements that minimize the risk of breakage that may occur in the system as a result of seismic (earthquake, building collapses, etc.) movements by damping the three dimensional movement as axial, lateral and angular and provide the continuity of the system by removing the stress on the rigid pipe. The Dilatation & Earthquake Expansion joints, which are designed to meet the movement in three different directions (axial, lateral and angular) are widely used in HVAC piping systems. They can also be used in places such as all building passages, Dilatation points etc.



Standard Product Materials		Optional Product Materials
Bellows	1.4301 (AISI 304)	1.4541 / 1.4401 / Titanium / Incoloy 800H / Inconel etc.
Joint Arms	1.0038 (St 37-2)	Stainless Steel
Grooved Connections	1.0038 (St 37-2)	Stainless Steel
Intermediate Pipe	1.0038 (St 37-2)	Stainless Steel

Design Parameters	
Design Pressure	16 Bar (1 Bar...64 Bar)
Design Temperature	+20 °C (-90°C...+550°C)
Diameters	DN25 (1")...DN300 (12")
Movements	X: $\pm 50$ mm, Y,Z: $\pm 50$ mm / Y,Z: $\pm 100$ mm / Y,Z: $\pm 150$ mm / Y,Z: $\pm 200$ mm
Design Standards	EJMA, EN 14917
Certifications	TSE, CE - Module H (Optional) - EAC

\*\*Please contact our sales team for your special requests.



Part Number	Specifications	
	Name	Material
1	Grooved Connection	1.0038 (S235JR / St37-2 - Galvanised)
2	Joint Arm	1.0038 (S235JR / St37-2 - Galvanised)
3	Intermediate Pipe	1.0038 (S235JR / St37-2 - Galvanised)
4	Bellows	1.4301 (AISI 304)

Diameters		LENGTH (L = mm)				A (mm)	B (mm)	C (mm)	ØD (mm)	M (mm)	Effective Area (cm <sup>2</sup> )
		KM100-YV	KM200-YV	KM300-YV	KM400-YV						
		X: ±50mm Y: ±50mm Z: ±50mm	X: ±50mm Y: ±100mm Z: ±100mm	X: ±50mm Y: ±150mm Z: ±150mm	X: ±50mm Y: ±200mm Z: ±200mm						
DN25	1"	710	910	1110	1310	15,8	7,1	1,6	33,7	170	19,0
DN32	1 1/4"	710	910	1110	1310	15,8	7,1	1,6	42,4	170	19,0
DN40	1 1/2"	710	910	1110	1310	15,8	7,1	1,6	48,3	170	24,7
DN50	2"	770	970	1170	1380	15,8	8,7	1,6	60,3	195	38,7
DN65	2 1/2"	770	970	1220	1480	15,8	8,7	1,9	76,1	210	58,0
DN80	3"	820	1020	1250	1480	15,8	8,7	1,9	88,9	220	80,5
DN100	4"	820	1020	1280	1530	15,8	8,7	2,1	114,3	265	129,0
DN125	5"	950	1150	1460	1750	15,8	8,7	2,1	139,7	310	191,8
DN150	6"	950	1150	1460	1750	15,8	8,7	2,1	165,1	335	262,7
DN200	8"	1120	1340	1690	2040	19,0	11,9	2,3	219,1	425	453,5
DN250	10"	1120	1340	1690	2040	19,0	11,9	2,3	273	470	698,4
DN300	12"	1080	1430	1830	2230	19,0	11,9	2,7	323,9	570	967,0

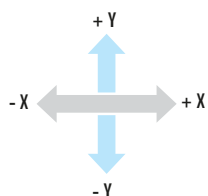
\*\* X,Y,Z value represents axial, lateral, angular movements. Please contact our technical department for different movement requirements.



Product Code	Definition
DK25 - F	Dilatation Expansion Joint With Tie Rods Flanged $\pm 25$ mm Expansion
DK50 - F	Dilatation Expansion Joint With Tie Rods Flanged $\pm 50$ mm Expansion
DK75 - F	Dilatation Expansion Joint With Tie Rods Flanged $\pm 75$ mm Expansion
DK100 - F	Dilatation Expansion Joint With Tie Rods Flanged $\pm 100$ mm Expansion

## GENERAL

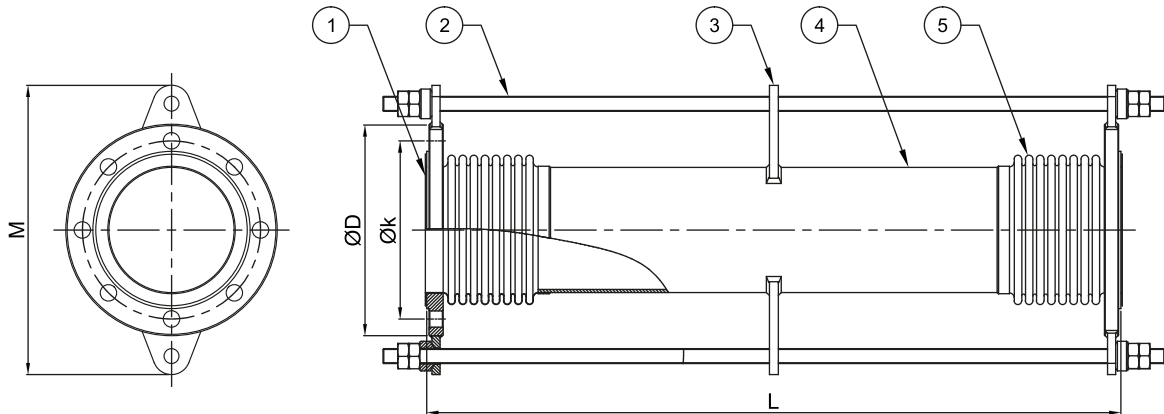
Dilatation expansion joints are the interconnection elements that ensure uninterrupted and efficient operation of the installation in the joints of buildings with different foundations (Dilatation), by absorbing strain and rupture that can occur in the pipelines due to building collapses or earthquakes, and lateral deviations. These types of expansion joints consisting of double bellows can be fixed to the desired expansion amounts by using limit rods. They can be used at all Dilatation points in building passages.



Standard Product Materials		Optional Product Materials
Bellows	1.4301 (AISI 304)	1.4541 / 1.4401 / Titanium / Incoloy 800H / Inconel etc.
Tie Rod Holders	1.0038 (St 37-2)	Stainless Steel
Flanges	1.0038 (St 37-2)	Stainless Steel
Intermediate Pipe	1.0038 (St 37-2)	Stainless Steel

Design Parameters	
Design Pressure	16 Bar (1 Bar...64 Bar)
Design Temperature	+20 °C (-90°C...+550°C)
Diameters	DN25 (1")...DN2500 (100")
Movements	X:60mm ( $\pm 30$ ), Y:50mm ( $\pm 25$ ) / 100mm ( $\pm 50$ ) / 150mm ( $\pm 75$ ) / 200mm ( $\pm 100$ )
Design Standards	EJMA, EN 14917
Certifications	TSE, CE - Module H (Optional) - EAC

\*\*Please contact our sales team for your special requests.



Part Number	Specifications	
	Name	Material
1	Flange	1.0038 (S235JR / St37-2)
2	Tie Rod	1.0038 (S235JR / St37-2)
3	Tie Rod Holder	1.0038 (S235JR / St37-2)
4	Intermediate Pipe	1.0038 (S235JR / St37-2)
5	Bellows	1.4301 (AISI 304)

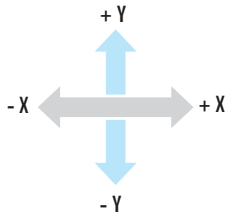
Diameters		LENGTH (L = mm)				ØD (mm)	Øk (mm)	Ødxn (mm)	M (mm)	Effective Area (cm²)
		DK25-F	DK50-F	DK75-F	DK100-F					
		X: ±30mm Y: ±25mm	X: ±30mm Y: ±50mm	X: ±30mm Y: ±75mm	X: ±30mm Y: ±100mm					
DN25	1"	260	360	460	560	115	85	14*4	205	19,0
DN32	1 1/4"	260	360	460	560	140	100	18*4	240	19,0
DN40	1 1/2"	260	360	460	560	150	110	18*4	250	24,7
DN50	2"	360	460	560	660	165	125	18*4	265	38,7
DN65	2 1/2"	360	460	560	660	185	145	18*4	285	58,0
DN80	3"	410	510	610	710	200	160	18*8	308	80,5
DN100	4"	410	510	610	710	220	180	18*8	328	129,0
DN125	5"	460	660	760	860	250	210	18*8	380	191,8
DN150	6"	460	660	760	860	285	240	22*8	413	262,7
DN200	8"	510	700	800	900	340	295	22*12	450	453,5
DN250	10"	600	800	900	1000	405	355	26*12	535	698,4
DN300	12"	640	845	940	1040	460	410	26*12	586	967,0
DN350	14"	705	1005	1045	1145	520	470	26*16	646	1149,6
DN400	16"	705	1010	1080	1180	580	525	30*16	740	1517,7
DN450	18"	740	1030	1130	1280	640	585	30*20	800	1884,2
DN500	20"	790	1090	1240	1590	715	650	33*20	895	2282,5

\*\* X,Y value represents axial, lateral movements. Please contact our technical department for different movement requirements.  
\*\* Flange diameters are according to PN16 pressure class.

Product Code	Definition
DK25 - KB	Dilatation Expansion Joint With Tie Rods Welding Ends ±25mm Expansion
DK50 - KB	Dilatation Expansion Joint With Tie Rods Welding Ends ±50mm Expansion
DK75 - KB	Dilatation Expansion Joint With Tie Rods Welding Ends ±75mm Expansion
DK100 - KB	Dilatation Expansion Joint With Tie Rods Welding Ends ±100mm Expansion

**GENERAL**

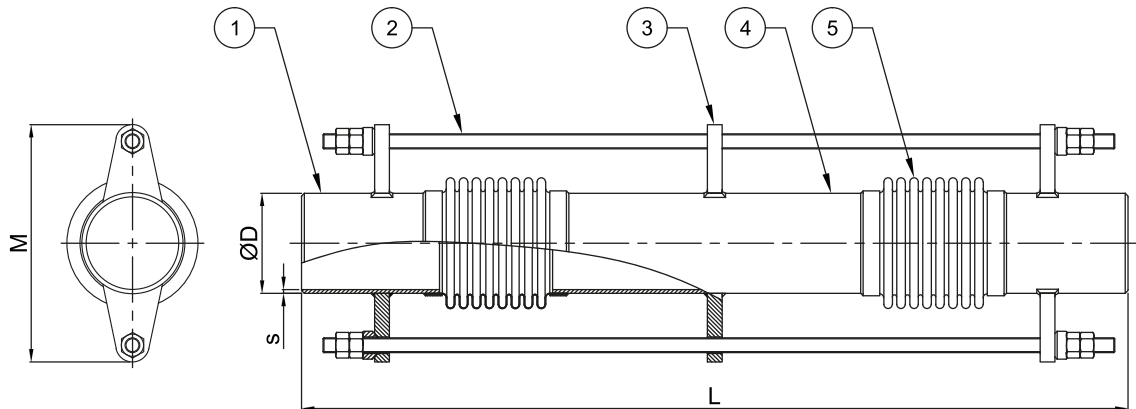
Dilatation expansion joints are the interconnection elements that ensure uninterrupted and efficient operation of the installation in the joints of buildings with different foundations (Dilatation), by absorbing strain and rupture that can occur in the pipelines due to building collapses or earthquakes, and lateral deviations. These types of expansion joints consisting of double bellows can be fixed to the desired expansion amounts by using limit rods. They can be used at all Dilatation points in building passages.



Standard Product Materials		Optional Product Materials
Bellows	1.4301 (AISI 304)	1.4541 / 1.4401 / Titanium / Incoloy 800H / Inconel etc.
Tie Rod Holders	1.0038 (St 37-2)	Stainless Steel
Welding Endss	1.0038 (St 37-2)	Stainless Steel
Intermediate Pipe	1.0038 (St 37-2)	Stainless Steel

Design Parameters	
Design Pressure	16 Bar (1 Bar...64 Bar)
Design Temperature	+20 °C (-90°C...+550°C)
Diameters	DN25 (1")...DN2500 (100")
Movements	X:60mm (±30), Y:50mm (±25) / 100mm (±50) / 150mm (±75) / 200mm (±100)
Design Standards	EJMA, EN 14917
Certifications	TSE, CE - Module H (Optional) - EAC

\*\*Please contact our sales team for your special requests.



Part Number	Specifications	
	Name	Material
1	Welding Ends	1.0038 (S235JR / St37-2)
2	Tie Rod	1.0038 (S235JR / St37-2)
3	Tie Rod Holder	1.0038 (S235JR / St37-2)
4	Intermediate Pipe	1.0038 (S235JR / St37-2)
5	Bellows	1.4301 (AISI 304)

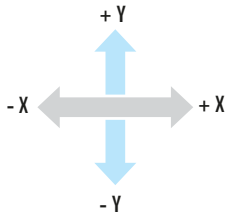
Diameters		LENGTH (L = mm)				ØD (mm)	s (mm)	M (mm)	Effective Area (cm <sup>2</sup> )
		DK25-KB	DK50-KB	DK75-KB	DK100-KB				
		X: ±30mm Y: ±25mm	X: ±30mm Y: ±50mm	X: ±30mm Y: ±75mm	X: ±30mm Y: ±100mm				
DN25	1"	550	650	750	850	33,7	3,2	136	19,0
DN32	1 1/4"	550	650	750	850	42,4	3,2	136	19,0
DN40	1 1/2"	550	650	750	850	48,3	3,2	147	24,7
DN50	2"	620	720	820	920	60,3	3,6	163	38,7
DN65	2 1/2"	620	720	820	920	76,1	3,6	190	58,0
DN80	3"	670	770	870	970	88,9	4	212	80,5
DN100	4"	670	770	870	970	114,3	4,5	245	129,0
DN125	5"	710	910	1010	1110	139,7	5	290	191,8
DN150	6"	710	910	1010	1110	165,1	5	340	262,7
DN200	8"	760	960	1050	1160	219,1	6,3	420	453,5
DN250	10"	860	1060	1150	1260	273	6,3	495	698,4
DN300	12"	945	1150	1245	1345	323,9	7,1	575	967,0
DN350	14"	1020	1320	1360	1460	355,6	8	622	1149,6
DN400	16"	1045	1350	1420	1520	406,4	8	713	1517,7
DN450	18"	1080	1370	1470	1620	457	8	780	1884,2
DN500	20"	1120	1420	1570	1920	508	8	845	2282,5

\*\* X,Y value represents axial, lateral movements. Please contact our technical department for different movement requirements.

Product Code	Definition
DK25 - YV	Dilatation Expansion Joint With Tie Rods Grooved $\pm 25$ mm Expansion
DK50 - YV	Dilatation Expansion Joint With Tie Rods Grooved $\pm 50$ mm Expansion
DK75 - YV	Dilatation Expansion Joint With Tie Rods Grooved $\pm 75$ mm Expansion
DK100 - YV	Dilatation Expansion Joint With Tie Rods Grooved $\pm 100$ mm Expansion

## GENERAL

Dilatation expansion joints are the interconnection elements that ensure uninterrupted and efficient operation of the installation in the joints of buildings with different foundations (Dilatation), by absorbing strain and rupture that can occur in the pipelines due to building collapses or earthquakes, and lateral deviations. These types of expansion joints consisting of double bellows can be fixed to the desired expansion amounts by using limit rods. They can be used at all Dilatation points in building passages.

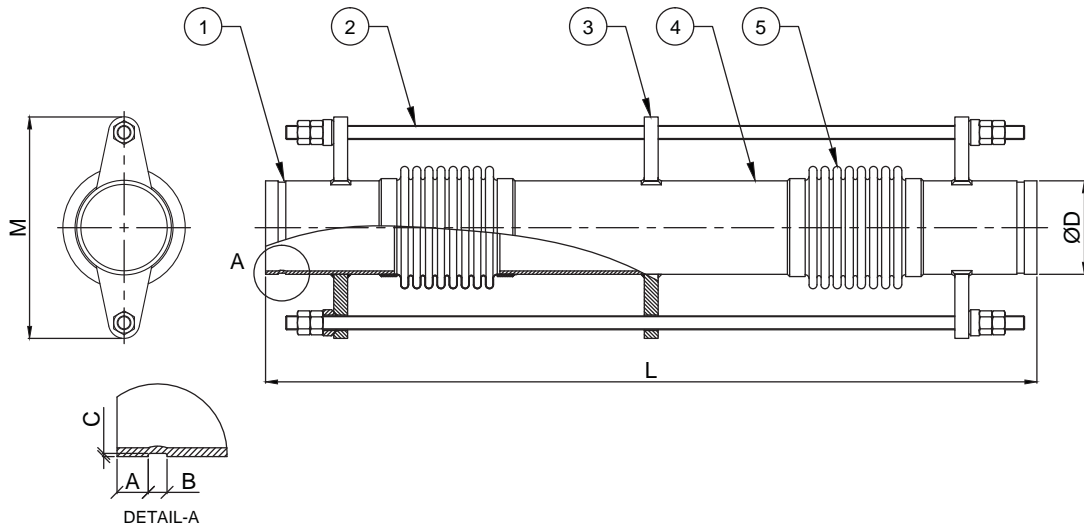


Standard Product Materials		Optional Product Materials
Bellows	1.4301 (AISI 304)	1.4541 / 1.4401 / Titanium / Incoloy 800H / Inconel etc.
Tie Rod Holders	1.0038 (St 37-2)	Stainless Steel
Grooved Connections	1.0038 (St 37-2)	Stainless Steel
Intermediate Pipe	1.0038 (St 37-2)	Stainless Steel

Design Parameters	
Design Pressure	16 Bar (1 Bar...64 Bar)
Design Temperature	+20 °C (-90°C...+550°C)
Diameters	DN25 (1")...DN2500 (100")
Movements	X:60mm ( $\pm 30$ ), Y:50mm ( $\pm 25$ ) / 100mm ( $\pm 50$ ) / 150mm ( $\pm 75$ ) / 200mm ( $\pm 100$ )
Design Standards	EJMA, EN 14917
Certifications	TSE, CE - Module H (Optional) - EAC

\*\*Please contact our sales team for your special requests.





Part Number	Specifications	
	Name	Material
1	Grooved Connection	1.0038 (S235JR / St37-2)
2	Tie Rod	1.0038 (S235JR / St37-2)
3	Tie Rod Holder	1.0038 (S235JR / St37-2)
4	Intermediate Pipe	1.0038 (S235JR / St37-2)
5	Bellows	1.4301 (AISI 304)

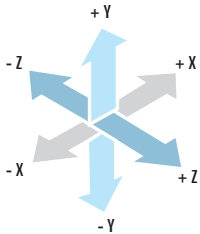
Diameters		LENGTH (L = mm)				A (mm)	B (mm)	C (mm)	ØD (mm)	M (mm)	Effective Area (cm²)
		DK25-YV	DK50-YV	DK75-YV	DK100-YV						
		X: ±30mm Y: ±25mm	X: ±30mm Y: ±50mm	X: ±30mm Y: ±75mm	X: ±30mm Y: ±100mm						
DN25	1"	550	650	750	850	15,8	7,1	1,6	33,7	136	19,0
DN32	1 1/4"	550	650	750	850	15,8	7,1	1,6	42,4	136	19,0
DN40	1 1/2"	550	650	750	850	15,8	7,1	1,6	48,3	147	24,7
DN50	2"	620	720	820	920	15,8	8,7	1,6	60,3	163	38,7
DN65	2 1/2"	620	720	820	920	15,8	8,7	1,9	76,1	190	58,0
DN80	3"	670	770	870	970	15,8	8,7	1,9	88,9	212	80,5
DN100	4"	670	770	870	970	15,8	8,7	2,1	114,3	245	129,0
DN125	5"	710	910	1010	1110	15,8	8,7	2,1	139,7	290	191,8
DN150	6"	710	910	1010	1110	15,8	8,7	2,1	165,1	340	262,7
DN200	8"	760	960	1050	1160	19,0	11,9	2,3	219,1	420	453,5
DN250	10"	860	1060	1150	1260	19,0	11,9	2,3	273	495	698,4
DN300	12"	945	1150	1245	1345	19,0	11,9	2,7	323,9	575	967,0

\*\* X,Y value represents axial, lateral movements. Please contact our technical department for different movement requirements.

Product Code	Definition
KM100-GD	Dilatation&Earthquake Expansion Joint Threaded Galvanised ±50mm Expansion
KM200-GD	Dilatation&Earthquake Expansion Joint Threaded Galvanised ±100mm Expansion
KM300-GD	Dilatation&Earthquake Expansion Joint Threaded Galvanised ±150mm Expansion
KM400-GD	Dilatation&Earthquake Expansion Joint Threaded Galvanised ±200mm Expansion

**GENERAL**

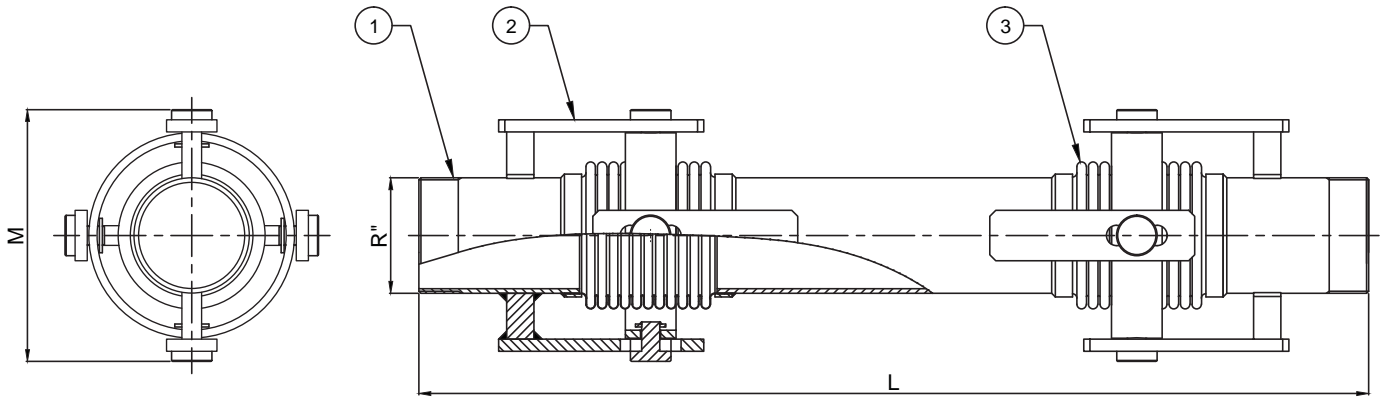
Dilatation & Earthquake expansion joints are the flexible connection elements that minimize the risk of breakage that may occur in the system as a result of seismic (earthquake, building collapses, etc.) movements by damping the three dimensional movement as axial, lateral and angular and provide the continuity of the system by removing the stress on the rigid pipe. The Dilatation & Earthquake Expansion joints, which are designed to meet the movement in three different directions (axial, lateral and angular) are widely used in domestic piping systems. They can also be used in places such as all building passages, Dilatation points etc..



Standard Product Materials		Optional Product Materials
Bellows	1.4301 (AISI 304)	1.4541 / 1.4401 / Titanium / Incoloy 800H / Inconel etc.
Joint Arms	1.0038 (St 37-2 Galvanised)	Stainless Steel
Threaded Connections	1.0038 (St 37-2 Galvanised)	Stainless Steel

Design Parameters	
Design Pressure	16 Bar (1 Bar...64 Bar)
Design Temperature	+20 °C
Diameters	DN25 (1")...DN300 (12")
Movements	X: ±50mm, Y,Z: ±50mm / Y,Z: ±100mm / Y,Z: ±150mm / Y,Z: 200mm
Design Standards	EJMA, EN 14917
Certifications	TSE, CE - Module H (Optional) - EAC

\*\*Please contact our sales team for your special requests.



Part Number	Specifications	
	Name	Material
1	Threaded Connection	1.0038 (S235JR / St37-2 - Galvanised)
2	Joint Arm	1.0038 (S235JR / St37-2 - Galvanised)
3	Bellows	1.4301 (AISI 304)

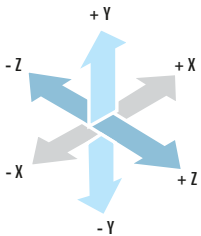
Diameters	LENGTH (L = mm)				M (mm)	Effective Area (cm <sup>2</sup> )
	KM100-GD	KM200-GD	KM300-GD	KM400-GD		
	X: ±50mm Y: ±50mm Z: ±50mm	X: ±50mm Y: ±100mm Z: ±100mm	X: ±50mm Y: ±150mm Z: ±150mm	X: ±50mm Y: ±200mm Z: ±200mm		
R 1"	930	1130	1330	1530	170	19,0
R 1 1/4"	810	1010	1210	1410	170	19,0
R 1 1/2"	810	1010	1210	1410	170	24,7
R 2"	870	1070	1270	1480	195	38,7
R 2 1/2"	870	1070	1320	1580	210	58,0
R 3"	920	1120	1350	1580	220	80,5
R 4"	920	1120	1380	1630	265	129,0
R 5"	1050	1250	1560	1850	310	191,8
R 6"	1050	1250	1560	1850	335	262,7

\*\* X,Y,Z value represents axial, lateral, angular movements. Please contact our technical department for different movement requirements.

Product Code	Definition
KM100 - GYV	Dilatation&Earthquake Expansion Joint Grooved Galvanised $\pm 50$ mm Expansion
KM200 - GYV	Dilatation&Earthquake Expansion Joint Grooved Galvanised $\pm 100$ mm Expansion
KM300 - GYV	Dilatation&Earthquake Expansion Joint Grooved Galvanised $\pm 150$ mm Expansion
KM400 - GYV	Dilatation&Earthquake Expansion Joint Grooved Galvanised $\pm 200$ mm Expansion

## GENERAL

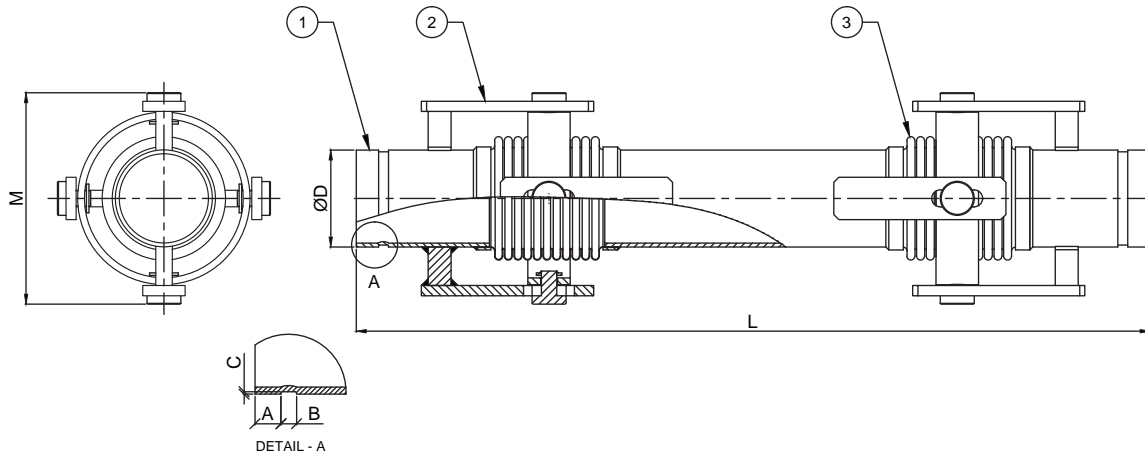
Dilatation & Earthquake expansion joints are the flexible connection elements that minimize the risk of breakage that may occur in the system as a result of seismic (earthquake, building collapses, etc.) movements by damping the three dimensional movement as axial, lateral and angular and provide the continuity of the system by removing the stress on the rigid pipe. The Dilatation & Earthquake Expansion joints, which are designed to meet the movement in three different directions (axial, lateral and angular) are widely used in domestic piping systems. They can also be used in places such as all building passages, Dilatation points etc.



Standard Product Materials		Optional Product Materials
Bellows	1.4301 (AISI 304)	1.4541 / 1.4401 / Titanium / Incoloy 800H / Inconel etc.
Joint Arms	1.0038 (St 37-2 Galvanised)	Stainless Steel
Grooved Connections	1.0038 (St 37-2 Galvanised)	Stainless Steel

Design Parameters	
Design Pressure	16 Bar (1 Bar...64 Bar)
Design Temperature	+20 °C
Diameters	DN25 (1")...DN300 (12")
Movements	X: $\pm 50$ mm Y,Z: $\pm 50$ mm / Y,Z: $\pm 100$ mm / Y,Z: $\pm 150$ mm / Y,Z: $\pm 200$ mm
Design Standards	EJMA, EN 14917
Certifications	TSE, CE - Module H (Optional) - EAC

\*\*Please contact our sales team for your special requests.



Part Number	Specifications	
	Name	Material
1	Grooved Connection	1.0038 (S235JR / St37-2 - Galvanised)
2	Joint Arm	1.0038 (S235JR / St37-2 - Galvanised)
3	Bellows	1.4301 (AISI 304)

Diameters		LENGTH (L = mm)				A (mm)	B (mm)	C (mm)	ØD (mm)	M (mm)	Effective Area (cm <sup>2</sup> )
		KM100-GYV	KM200-GYV	KM300-GYV	KM400-GYV						
		X: ±50mm Y: ±50mm Z: ±50mm	X: ±50mm Y: ±100mm Z: ±100mm	X: ±50mm Y: ±150mm Z: ±150mm	X: ±50mm Y: ±200mm Z: ±200mm						
DN25	1"	710	910	1110	1310	15,8	7,1	1,6	33,7	170	19,0
DN32	1 1/4"	710	910	1110	1310	15,8	7,1	1,6	42,4	170	19,0
DN40	1 1/2"	710	910	1110	1310	15,8	7,1	1,6	48,3	170	24,7
DN50	2"	770	970	1170	1380	15,8	8,7	1,6	60,3	195	38,7
DN65	2 1/2"	770	970	1220	1480	15,8	8,7	1,9	76,1	210	58,0
DN80	3"	820	1020	1250	1480	15,8	8,7	1,9	88,9	220	80,5
DN100	4"	820	1020	1280	1530	15,8	8,7	2,1	114,3	265	129,0
DN125	5"	950	1150	1460	1750	15,8	8,7	2,1	139,7	310	191,8
DN150	6"	950	1150	1460	1750	15,8	8,7	2,1	165,1	335	262,7
DN200	8"	1120	1340	1690	2040	19,0	11,9	2,3	219,1	425	453,5
DN250	10"	1120	1340	1690	2040	19,0	11,9	2,3	273	470	698,4
DN300	12"	1080	1430	1830	2230	19,0	11,9	2,7	323,9	570	967,0

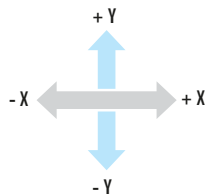
\*\* X,Y,Z value represents axial, lateral, angular movements. Please contact our technical department for different movement requirements.



Product Code	Definition
DK25 - GD	Dilatation Expansion Joint With Tie Rods Threaded Galvanised $\pm 25$ mm Expansion
DK50 - GD	Dilatation Expansion Joint With Tie Rods Threaded Galvanised $\pm 50$ mm Expansion
DK75 - GD	Dilatation Expansion Joint With Tie Rods Threaded Galvanised $\pm 75$ mm Expansion
DK100 - GD	Dilatation Expansion Joint With Tie Rods Threaded Galvanised $\pm 100$ mm Expansion

## GENERAL

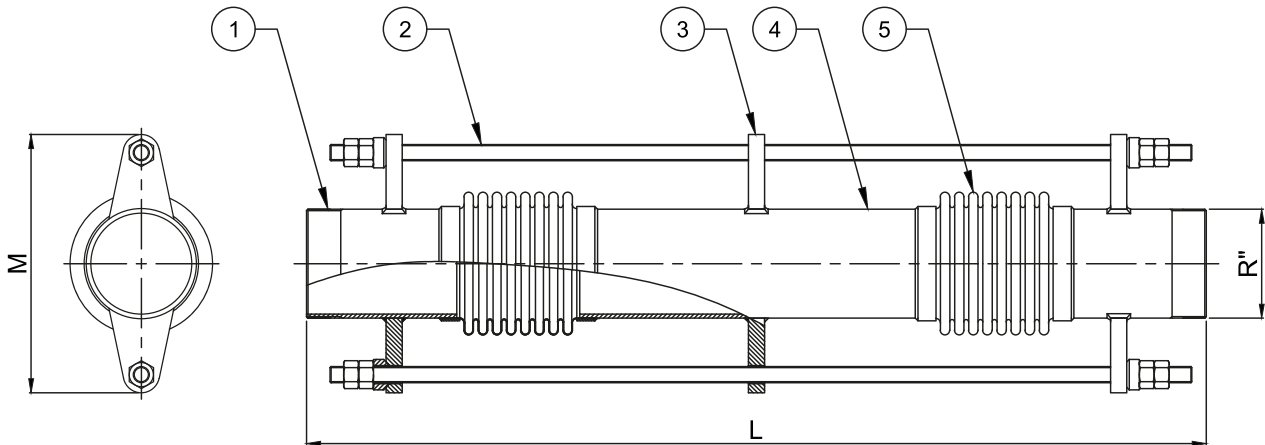
Dilatation expansion joints are the interconnection elements that ensure uninterrupted and efficient operation of the installation in the joints of buildings with different foundations (Dilatation), by absorbing strain and rupture that can occur in the pipelines due to building collapses or earthquakes, and lateral deviations. These types of expansion joints consisting of double bellows can be fixed to the desired expansion amounts by using limit rods. They can be used at all Dilatation points in building passages.



Standard Product Materials		Optional Product Materials
Bellows	1.4301 (AISI 304)	1.4541 / 1.4401 / Titanium / Incoloy 800H / Inconel etc.
Tie Rod Holders	1.0038 (St 37-2 Galvanised)	Stainless Steel
Threaded Connections	1.0038 (St 37-2 Galvanised)	Stainless Steel

Design Parameters	
Design Pressure	16 Bar (1 Bar...64 Bar Optional)
Design Temperature	+20 °C
Diameters	DN25 (1")...DN300 (12")
Movements	X:60mm ( $\pm 30$ ), Y:50mm ( $\pm 25$ ) / 100mm ( $\pm 50$ ) / 150mm ( $\pm 75$ ) / 200mm ( $\pm 100$ )
Design Standards	EJMA, EN 14917
Certifications	TSE, CE - Module H (Optional) - EAC

\*\*Please contact our sales team for your special requests.



Part Number	Specifications	
	Name	Material
1	Threaded Connection	1.0038 (S235JR / St37-2 - Galvanised)
2	Tie Rod	1.0038 (S235JR / St37-2 - Galvanised)
3	Tie Rod Holder	1.0038 (S235JR / St37-2 - Galvanised)
4	Bellows	1.4301 (AISI 304)

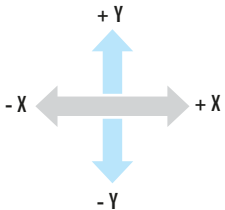
Diameters	LENGTH (L = mm)				M (mm)	Effective Area (cm <sup>2</sup> )
	DK25-GD	DK50-GD	DK75-GD	DK100-GD		
	X: ±30mm Y: ±25mm	X: ±30mm Y: ±50mm	X: ±30mm Y: ±75mm	X: ±30mm Y: ±100mm		
R 1"	770	870	970	1070	136	19,0
R 1 1/4"	650	750	850	950	136	19,0
R 1 1/2"	650	750	850	950	147	24,7
R 2"	720	820	920	1020	163	38,7
R 2 1/2"	720	820	920	1020	190	58,0
R 3"	770	870	970	1070	212	80,5
R 4"	770	870	970	1070	245	129,0
R 5"	810	1010	1110	1210	290	191,8
R 6"	810	1010	1110	1210	340	262,7

\*\* X,Y value represents axial, lateral movements. Please contact our technical department for different movement requirements.

Product Code	Definition
DK25 - GYV	Dilatation Expansion Joint With Tie Rods Grooved Galvanised $\pm 25$ mm Expansion
DK50 - GYV	Dilatation Expansion Joint With Tie Rods Grooved Galvanised $\pm 50$ mm Expansion
DK75 - GYV	Dilatation Expansion Joint With Tie Rods Grooved Galvanised $\pm 75$ mm Expansion
DK100 - GYV	Dilatation Expansion Joint With Tie Rods Grooved Galvanised $\pm 100$ mm Expansion

## GENERAL

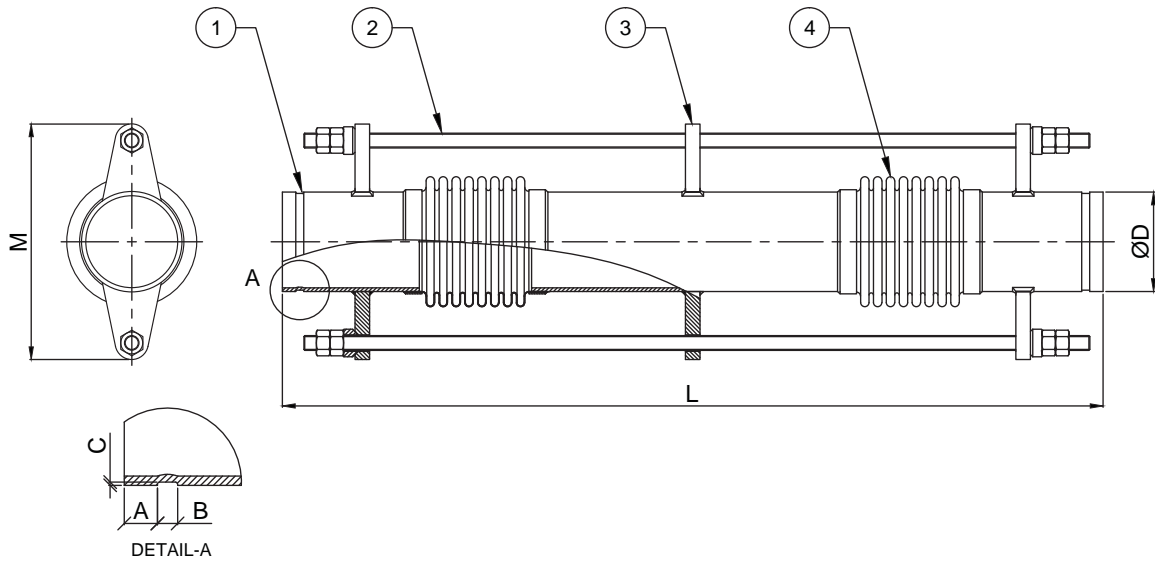
Dilatation expansion joints are the interconnection elements that ensure uninterrupted and efficient operation of the installation in the joints of buildings with different foundations (Dilatation), by absorbing strain and rupture that can occur in the pipelines due to building collapses or earthquakes, and lateral deviations. These types of expansion joints consisting of double bellows can be fixed to the desired expansion amounts by using limit rods. They can be used at all Dilatation points in building passages.



Standard Product Materials		Optional Product Materials
Bellows	1.4301 (AISI 304)	1.4541 / 1.4401 / Titanium / Incoloy 800H / Inconel etc.
Tie Rod Holders	1.0038 (St 37-2 Galvanised)	Stainless Steel
Grooved Connections	1.0038 (St 37-2 Galvanised)	Stainless Steel

Design Parameters	
Design Pressure	16 Bar (1 Bar...64 Bar Optional)
Design Temperature	+20°C
Diameters	DN25 (1")...DN300 (12")
Movements	X:60mm ( $\pm 30$ ), Y:50mm ( $\pm 25$ ) / 100mm ( $\pm 50$ ) / 150mm ( $\pm 75$ ) / 200mm ( $\pm 100$ )
Standards	EJMA, EN 14917
Certifications	TSE, CE Module H (Optional) - EAC

\*\*Please contact our sales team for your special requests.



Part Number	Specifications	
	Name	Material
1	Grooved Connections	1.0038 (S235JR / St37-2 - Galvanised)
2	Tie Rod	1.0038 (S235JR / St37-2)
3	Tie Rod Holder	1.0038 (S235JR / St37-2 - Galvanised)
4	Bellows	1.4301 (AISI 304)

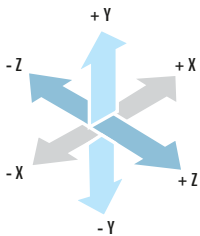
Diameters		LENGTH (L = mm)				A (mm)	B (mm)	C (mm)	ØD (mm)	M (mm)	Effective Area (cm <sup>2</sup> )
		DK25-GYV	DK50-GYV	DK75-GYV	DK100-GYV						
		X: ±30mm Y: ±25mm	X: ±30mm Y: ±50mm	X: ±30mm Y: ±75mm	X: ±30mm Y: ±100mm						
DN25	1"	550	650	750	850	15,8	7,1	1,6	33,7	136	19,0
DN32	1 1/4"	550	650	750	850	15,8	7,1	1,6	42,4	136	19,0
DN40	1 1/2"	550	650	750	850	15,8	7,1	1,6	48,3	147	24,7
DN50	2"	620	720	820	920	15,8	8,7	1,6	60,3	163	38,7
DN65	2 1/2"	620	720	820	920	15,8	8,7	1,9	76,1	190	58,0
DN80	3"	670	770	870	970	15,8	8,7	1,9	88,9	212	80,5
DN100	4"	670	770	870	970	15,8	8,7	2,1	114,3	245	129,0
DN125	5"	710	910	1010	1110	15,8	8,7	2,1	139,7	290	191,8
DN150	6"	710	910	1010	1110	15,8	8,7	2,1	165,1	340	262,7
DN200	8"	760	960	1050	1160	19,0	11,9	2,3	219,1	420	453,5
DN250	10"	860	1060	1150	1260	19,0	11,9	2,3	273	495	698,4
DN300	12"	945	1150	1245	1345	19,0	11,9	2,7	323,9	575	967,0

\*\* X,Y value represents axial, lateral movements. Please contact our technical department for different movement requirements.

FM Code	Product Code	Definition
KMKBYF	KM100 - FFM	Dilatation & Earthquake Expansion Joint FM Approved Flanged ±50mm Expansion
KMKBYF	KM200 - FFM	Dilatation & Earthquake Expansion Joint FM Approved Flanged ±100mm Expansion
KMKBYF	KM300 - FFM	Dilatation & Earthquake Expansion Joint FM Approved Flanged ±150mm Expansion
KMKBYF	KM400 - FFM	Dilatation & Earthquake Expansion Joint FM Approved Flanged ±200mm Expansion

**GENERAL**

Dilatation & Earthquake expansion joints are the flexible connection elements that minimize the risk of breakage that may occur in the system as a result of seismic (earthquake, building collapses, etc.) movements by damping the three dimensional movement as axial, lateral and angular and provide the continuity of the system by removing the stress on the rigid pipe. The Dilatation & Earthquake Expansion joints, which are designed to meet the movement in three different directions (axial, lateral and angular) are widely used in fire circuits since they are FM approved. They can also be used in places such as all building passages, Dilatation points etc.

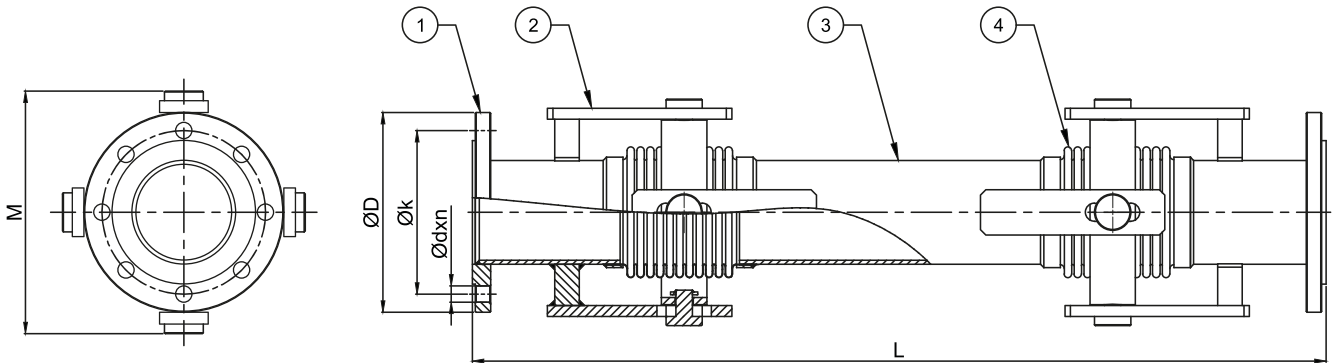


Standard Product Materials		Optional Product Materials	
Bellows	1.4301 (AISI 304)	1.4541 / 1.4401 / Titanium / Incoloy 800H / Inconel etc.	
Joint Arms	1.0038 (St 37-2)	Stainless Steel	
Flanges	1.0038 (St 37-2)	Stainless Steel	
Intermediate Pipe	1.0038 (St 37-2)	Stainless Steel	

Design Parameters	
Design Pressure	250 psi
Design Temperature	+20°C (+90°C...+550°C)
Diameters	DN25 (1")...DN300 (100")
Movements	X:±50mm, Y,Z:±50mm / Y,Z:±100mm / Y,Z:±150mm / Y,Z:±200mm
Standards	EJMA, EN 14917
Certifications	FM Approved - TSE - CE Module H (Optional) - EAC

\*\*Please contact our sales team for your special requests.





Part Number	Specifications	
	Name	Material
1	Flange	1.0038 (S235JR / St37-2)
2	Joint Arm	1.0038 (S235JR / St37-2)
3	Intermediate Pipe	1.0038 (S235JR / St37-2)
4	Bellows	1.4301 (AISI 304)

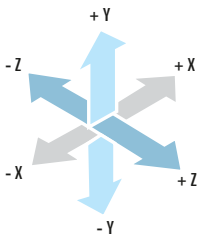
Diameters	LENGTH (L = mm)					ØD (mm)	Øk (mm)	Ød x n (mm)	M (mm)	Effective Area (cm <sup>2</sup> )
	KMKBYF									
	KM100-FFM	KM200-FFM	KM300-FFM	KM400-FFM						
	X: ±50mm Y: ±50mm Z: ±50mm	X: ±50mm Y: ±100mm Z: ±100mm	X: ±50mm Y: ±150mm Z: ±150mm	X: ±50mm Y: ±200mm Z: ±200mm						
DN25	1"	730	930	1130	1330	115	85	14*4	160	19,0
DN32	1 1/4"	730	930	1130	1330	140	100	18*4	160	19,0
DN40	1 1/2"	730	930	1130	1330	150	110	18*4	160	24,7
DN50	2"	790	990	1190	1400	165	125	18*4	185	38,7
DN65	2 1/2"	790	990	1240	1500	185	145	18*4	205	58,0
DN80	3"	840	1040	1270	1500	200	160	18*8	215	80,5
DN100	4"	840	1040	1300	1550	220	180	18*8	280	129,0
DN125	5"	970	1170	1480	1770	250	210	18*8	335	191,8
DN150	6"	970	1170	1480	1770	285	240	22*8	345	262,7
DN200	8"	1140	1360	1710	2060	340	295	22*12	435	453,5
DN250	10"	1140	1360	1710	2060	405	355	26*12	495	698,4
DN300	12"	1170	1545	1920	2285	460	410	26*12	565	967,0

\*\* X,Y,Z value represents axial, lateral, angular movements. Please contact our technical department for different movement requirements.  
\*\* Flange diameters are according to PN16 pressure class.

FM Code	Product Code	Definition
KMKBYF	KM100 - KBFM	Dilatation & Earthquake Expansion Joint FM Approved Welding Ends $\pm 50$ mm Expansion
KMKBYF	KM200 - KBFM	Dilatation & Earthquake Expansion Joint FM Approved Welding Ends $\pm 100$ mm Expansion
KMKBYF	KM300 - KBFM	Dilatation & Earthquake Expansion Joint FM Approved Welding Ends $\pm 150$ mm Expansion
KMKBYF	KM400 - KBFM	Dilatation & Earthquake Expansion Joint FM Approved Welding Ends $\pm 200$ mm Expansion

**GENERAL**

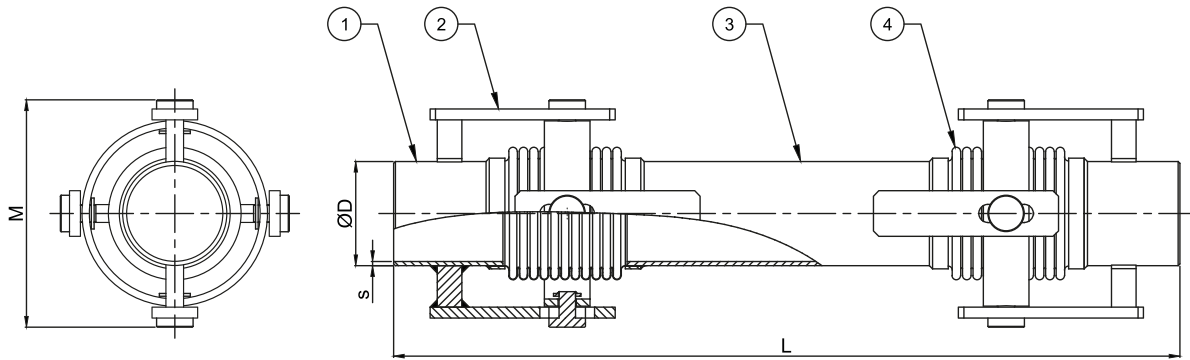
Dilatation & Earthquake expansion joints are the flexible connection elements that minimize the risk of breakage that may occur in the system as a result of seismic (earthquake, building collapses, etc.) movements by damping the three dimensional movement as axial, lateral and angular and provide the continuity of the system by removing the stress on the rigid pipe. The Dilatation & Earthquake Expansion joints, which are designed to meet the movement in three different directions (axial, lateral and angular) are widely used in fire circuits since they are FM approved. They can also be used in places such as all building passages, Dilatation points etc.



Standard Product Materials		Optional Product Materials	
Bellows	1.4301 (AISI 304)	1.4541 / 1.4401 / Titanium / Incoloy 800H / Inconel etc.	
Joint Arms	1.0038 (St 37-2)	Stainless Steel	
Welding Ends	1.0038 (St 37-2)	Stainless Steel	
Intermediate Pipe	1.0038 (St 37-2)	Stainless Steel	

Design Parameters	
Design Pressure	250 psi
Design Temperature	+20°C (+90°C...+550°C)
Diameters	DN25 (1")...DN300 (12")
Movements	X: $\pm 50$ mm ; Y,Z: $\pm 50$ mm / Y,Z: $\pm 100$ mm / Y,Z: $\pm 150$ mm / Y,Z: $\pm 200$ mm
Standards	EJMA, EN 14917
Certifications	FM Approved - TSE - CE Module H (Optional) - EAC

\*\*Please contact our sales team for your special requests.



Part Number	Specifications	
	Name	Material
1	Welding Ends	1.0038 (S235JR / St37-2)
2	Joint Arm	1.0038 (S235JR / St37-2)
3	Intermediate Pipe	1.0038 (S235JR / St37-2)
4	Bellows	1.4301 (AISI 304)

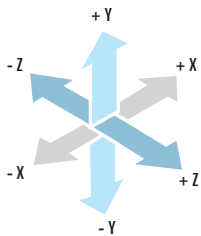
Diameters		LENGTH (L = mm)				ØD (mm)	s (mm)	M (mm)	Effective Area (cm <sup>2</sup> )
		KMKBYF							
		KM100-KBFM	KM200-KBFM	KM300-KBFM	KM400-KBFM				
		X: ±50mm Y: ±50mm Z: ±50mm	X: ±50mm Y: ±100mm Z: ±100mm	X: ±50mm Y: ±150mm Z: ±150mm	X: ±50mm Y: ±200mm Z: ±200mm				
DN25	1"	710	910	1110	1310	33,7	3,2	160	19,0
DN32	1 1/4"	710	910	1110	1310	42,4	3,2	160	19,0
DN40	1 1/2"	710	910	1110	1310	48,3	3,2	160	24,7
DN50	2"	770	970	1170	1380	60,3	3,6	185	38,7
DN65	2 1/2"	770	970	1220	1480	76,1	3,6	205	58,0
DN80	3"	820	1020	1250	1480	88,9	4	215	80,5
DN100	4"	820	1020	1280	1530	114,3	4,5	280	129,0
DN125	5"	950	1150	1460	1750	139,7	5	335	191,8
DN150	6"	950	1150	1460	1750	165,1	5	345	262,7
DN200	8"	1120	1340	1690	2040	219,1	6,3	435	453,5
DN250	10"	1120	1340	1690	2040	273	6,3	495	698,4
DN300	12"	1150	1525	1900	2265	323,9	7,1	565	967,0

\*\* X,Y,Z value represents axial, lateral, angular movements. Please contact our technical department for different movement requirements.

FM Code	Product Code	Definition
KMKBYF	KM100 - YVFM	Dilatation & Earthquake Expansion Joint FM Approved Grooved $\pm 50$ mm Expansion
KMKBYF	KM200 - YVFM	Dilatation & Earthquake Expansion Joint FM Approved Grooved $\pm 100$ mm Expansion
KMKBYF	KM300 - YVFM	Dilatation & Earthquake Expansion Joint FM Approved Grooved $\pm 150$ mm Expansion
KMKBYF	KM400 - YVFM	Dilatation & Earthquake Expansion Joint FM Approved Grooved $\pm 200$ mm Expansion

**GENERAL**

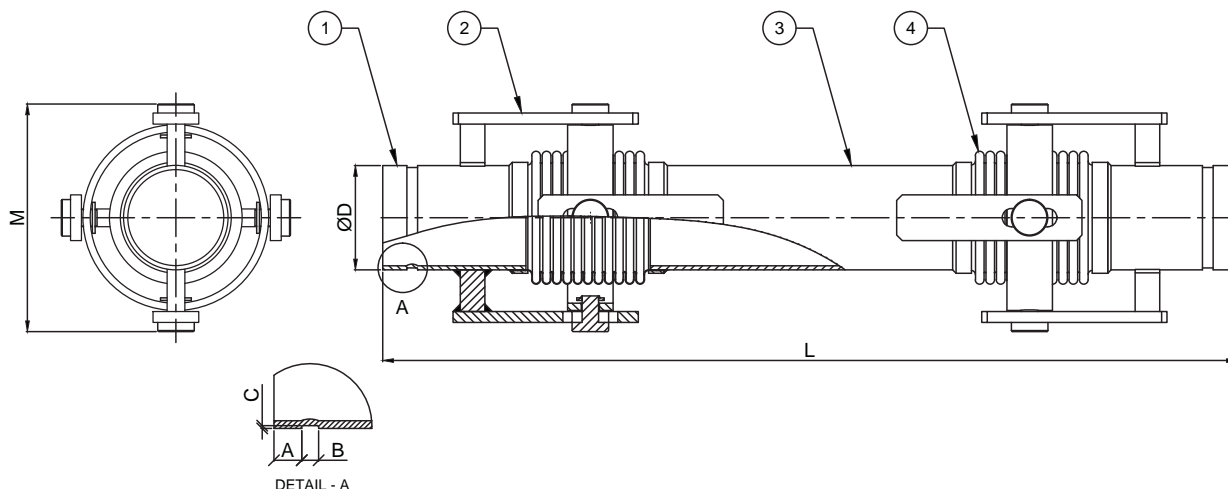
Dilatation & Earthquake expansion joints are the flexible connection elements that minimize the risk of breakage that may occur in the system as a result of seismic (earthquake, building collapses, etc.) movements by damping the three dimensional movement as axial, lateral and angular and provide the continuity of the system by removing the stress on the rigid pipe. The Dilatation & Earthquake Expansion joints, which are designed to meet the movement in three different directions (axial, lateral and angular) are widely used in fire circuits since they are FM approved. They can also be used in places such as all building passages, Dilatation points etc.



Standard Product Materials		Optional Product Materials	
Bellows	1.4301 (AISI 304)	1.4541 / 1.4401 / Titanium / Incoloy 800H / Inconel etc.	
Joint Arms	1.0038 (St 37-2)	Stainless Steel	
Grooved Connections	1.0038 (St 37-2)	Stainless Steel	
Intermediate Pipe	1.0038 (St 37-2)	Stainless Steel	

Design Parameters	
Design Pressure	250 psi
Design Temperature	+20°C (+90°C...+550°C)
Diameters	DN25 (1")...DN300 (12")
Movements	X: $\pm 50$ mm, Y,Z: $\pm 50$ mm / Y,Z: $\pm 100$ mm / Y,Z: $\pm 150$ mm / Y,Z: $\pm 200$ mm
Standards	EJMA, EN 14917
Certifications	FM Approved - TSE - CE Module H (Optional) - EAC

\*\*Please contact our sales team for your special requests.



Part Number	Specifications	
	Name	Material
1	Grooved Connections	1.0038 (S235JR / St37-2)
2	Joint Arm	1.0038 (S235JR / St37-2)
3	Intermediate Pipe	1.0038 (S235JR / St37-2)
4	Bellows	1.4301 (AISI 304)

Diameters	LENGTH (L = mm)				A (mm)	B (mm)	C (mm)	ØD (mm)	M (mm)	Effective Area (cm <sup>2</sup> )
	KMKBYF									
	KM100-YVFM X: ±50mm Y: ±50mm Z: ±50mm	KM200-YVFM X: ±50mm Y: ±100mm Z: ±100mm	KM300-YVFM X: ±50mm Y: ±150mm Z: ±150mm	KM400-YVFM X: ±50mm Y: ±200mm Z: ±200mm						
DN25 1"	710	910	1110	1310	15,8	7,1	1,6	33,7	160	19,0
DN32 1 1/4"	710	910	1110	1310	15,8	7,1	1,6	42,4	160	19,0
DN40 1 1/2"	710	910	1110	1310	15,8	7,1	1,6	48,3	160	24,7
DN50 2"	770	970	1170	1380	15,8	8,7	1,6	60,3	185	38,7
DN65 2 1/2"	770	970	1220	1480	15,8	8,7	1,9	76,1	205	58,0
DN80 3"	820	1020	1250	1480	15,8	8,7	1,9	88,9	215	80,5
DN100 4"	820	1020	1280	1530	15,8	8,7	2,1	114,3	280	129,0
DN125 5"	950	1150	1460	1750	15,8	8,7	2,1	139,7	335	191,8
DN150 6"	950	1150	1460	1750	15,8	8,7	2,1	165,1	345	262,7
DN200 8"	1120	1340	1690	2040	19,0	11,9	2,3	219,1	435	453,5
DN250 10"	1120	1340	1690	2040	19,0	11,9	2,3	273	495	698,4
DN300 12"	1150	1525	1900	2265	19,0	11,9	2,7	323,9	565	967,0

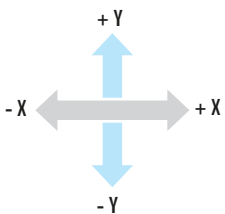
\*\* X,Y,Z value represents axial, lateral, angular movements. Please contact our technical department for different movement requirements.



FM Code	Product Code	Definition
DKLRKBYF	DK25 - FFM	Dilatation Expansion Joint With Tie Rods FM Approved Flanged $\pm 25$ mm Expansion
DKLRKBYF	DK50 - FFM	Dilatation Expansion Joint With Tie Rods FM Approved Flanged $\pm 50$ mm Expansion
DKLRKBYF	DK75 - FFM	Dilatation Expansion Joint With Tie Rods FM Approved Flanged $\pm 75$ mm Expansion
DKLRKBYF	DK100 - FFM	Dilatation Expansion Joint With Tie Rods FM Approved Flanged $\pm 100$ mm Expansion

**GENERAL**

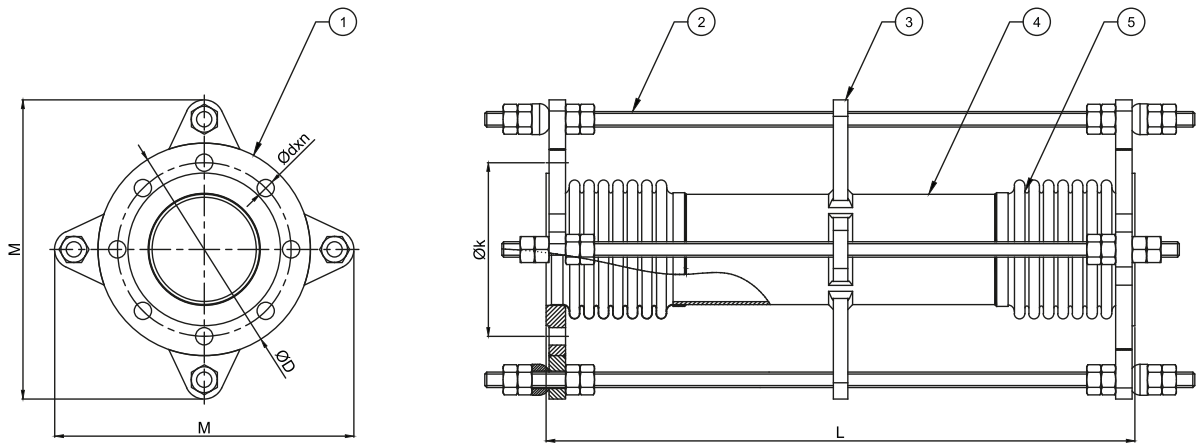
Dilatation expansion joints are the interconnection elements that ensure uninterrupted and efficient operation of the installation in the joints of buildings with different foundations (Dilatation), by absorbing strain and rupture that can occur in the pipelines due to building collapses or earthquakes, and lateral deviations. These types of expansion joints consisting of double bellows can be fixed to the desired expansion amounts by using limit rods. They can be used at all Dilatation points in building passages.



Standard Product Materials		Optional Product Materials
Bellows	1.4301 (AISI 304)	1.4541 / 1.4401 / Titanium / Incoloy 800H / Inconel etc.
Tie Rod Holders	1.0038 (St 37-2)	Stainless Steel
Flanges	1.0038 (St 37-2)	Stainless Steel
Intermediate Pipe	1.0038 (St 37-2)	Stainless Steel

Design Parameters	
Design Pressure	250 psi
Design Temperature	+20°C (-90°C...+550°C)
Diameters	DN25 (1")...DN250 (10")
Movements	X:60mm( $\pm 30$ ), Y:50mm ( $\pm 25$ ) / 100mm ( $\pm 50$ ) / 150mm ( $\pm 75$ ) / 200mm ( $\pm 100$ )
Standards	EJMA, EN 14917
Certifications	FM Approved - TSE - CE Module H (Optional) - EAC

\*\*Please contact our sales team for your special requests.



Part Number	Specifications	
	Name	Material
1	Flange	1.0038 (S235JR / St37-2)
2	Tie Rod	1.0038 (S235JR / St37-2)
3	Tie Rod Holder	1.0038 (S235JR / St37-2)
4	Intermediate Pipe	1.0038 (S235JR / St37-2)
5	Bellows	1.4301 (AISI 304)

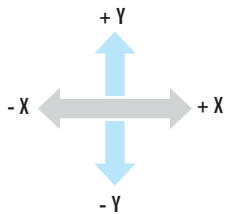
Diameters		LENGTH (L = mm)				ØD (mm)	Øk (mm)	Ødxn (mm)	M (mm)	Effective Area (cm²)
		DKLRKBYF								
		DK25-FFM	DK50-FFM	DK75-FFM	DK100-FFM					
		X: ±30mm Y: ±25mm	X: ±30mm Y: ±50mm	X: ±30mm Y: ±75mm	X: ±30mm Y: ±100mm					
DN25	1"	260	360	460	560	115	85	14*4	195	19,0
DN32	1 1/4"	260	360	460	560	140	100	18*4	240	19,0
DN40	1 1/2"	260	360	460	560	150	110	18*4	254	24,7
DN50	2"	360	460	560	660	165	125	18*4	273	38,7
DN65	2 1/2"	360	460	560	660	185	145	18*4	285	58,0
DN80	3"	410	510	610	710	200	160	18*8	308	80,5
DN100	4"	410	510	610	710	220	180	18*8	328	129,0
DN125	5"	460	660	760	860	250	210	18*8	358	191,8
DN150	6"	460	660	760	860	285	240	22*8	413	262,7
DN200	8"	510	700	800	900	340	295	22*12	468	453,5
DN250	10"	600	800	900	1000	405	355	26*12	557	698,4

\*\* X,Y value represents axial, lateral movements. Please contact our technical department for different movement requirements.  
\*\* Flange diameters are according to PN16 pressure class.

FM Code	Product Code	Definition
DKLRKBYF	DK25 - KBFM	Dilatation Expansion Joint With Tie Rods FM Approved Welding Ends ±25mm Expansion
DKLRKBYF	DK50 - KBFM	Dilatation Expansion Joint With Tie Rods FM Approved Welding Ends ±50mm Expansion
DKLRKBYF	DK75 - KBFM	Dilatation Expansion Joint With Tie Rods FM Approved Welding Ends ±75mm Expansion
DKLRKBYF	DK100 - KBFM	Dilatation Expansion Joint With Tie Rods FM Approved Welding Ends ±100mm Expansion

**GENERAL**

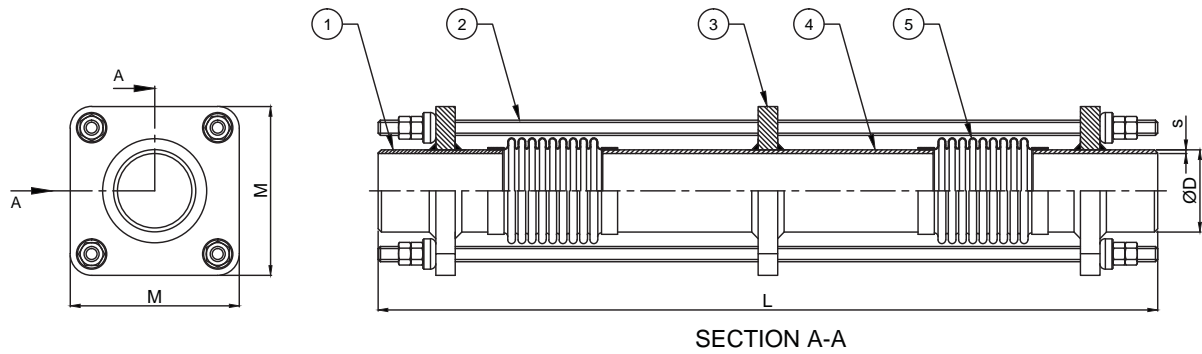
Dilatation expansion joints are the interconnection elements that ensure uninterrupted and efficient operation of the installation in the joints of buildings with different foundations (Dilatation), by absorbing strain and rupture that can occur in the pipelines due to building collapses or earthquakes, and lateral deviations. These types of expansion joints consisting of double bellows can be fixed to the desired expansion amounts by using limit rods. They can be used at all Dilatation points in building passages.



Standard Product Materials		Optional Product Materials	
Bellows	1.4301 (AISI 304)	1.4541 / 1.4401 / Titanium / Incoloy 800H / Inconel etc.	
Tie Rod Holders	1.0038 (St 37-2)	Stainless Steel	
Welding Ends	1.0038 (St 37-2)	Stainless Steel	
Intermediate Pipe	1.0038 (St 37-2)	Stainless Steel	

Design Parameters	
Design Pressure	250 psi
Design Temperature	+20°C (+90°C...+550°C)
Diameters	DN25 (1")...DN250 (10")
Movements	X:60mm (±30), Y: 50mm (±25) / 100mm (±50) / 150mm (±75) / 200mm (±100)
Standards	EJMA, EN 14917
Certifications	FM Approved - TSE - CE Module H (Optional) - EAC

\*\*Please contact our sales team for your special requests.



Part Number	Specifications	
	Name	Material
1	Welding Ends	1.0038 (S235JR / St37-2)
2	Tie Rod	1.0038 (S235JR / St37-2)
3	Tie Rod Holder	1.0038 (S235JR / St37-2)
4	Intermediate Pipe	1.0038 (S235JR / St37-2)
5	Bellows	1.4301 (AISI 304)

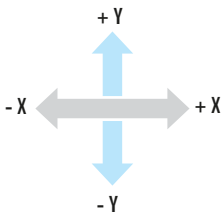
Diameters		LENGTH (L = mm)				ØD (mm)	s (mm)	M (mm)	Effective Area (cm <sup>2</sup> )
		DKLRKBYF							
		DK25-KBFM	DK50-KBFM	DK75-KBFM	DK100-KBFM				
		X: ±30mm Y: ±25mm	X: ±30mm Y: ±50mm	X: ±30mm Y: ±75mm	X: ±30mm Y: ±100mm				
DN25	1"	550	650	750	850	33,7	3,2	111	19,0
DN32	1 1/4"	550	650	750	850	42,4	3,2	111	19,0
DN40	1 1/2"	550	650	750	850	48,3	3,2	111	24,7
DN50	2"	620	720	820	920	60,3	3,6	120	38,7
DN65	2 1/2"	620	720	820	920	76,1	3,6	156	58,0
DN80	3"	670	770	870	970	88,9	4	165	80,5
DN100	4"	670	770	870	970	114,3	4,5	183	129,0
DN125	5"	710	910	1010	1110	139,7	5	227	191,8
DN150	6"	710	910	1010	1110	165,1	5	247	262,7
DN200	8"	760	960	1050	1260	219,1	6,3	308	453,5
DN250	10"	860	1060	1150	1260	273	6,3	346	698,4

\*\* X,Y value represents axial, lateral movements. Please contact our technical department for different movement requirements.

FM Code	Product Code	Definition
DKLRKBYF	DK25-YVFM	Dilatation Expansion Joint With Tie Rods FM Approved Grooved $\pm 25$ mm Expansion
DKLRKBYF	DK50-YVFM	Dilatation Expansion Joint With Tie Rods FM Approved Grooved $\pm 50$ mm Expansion
DKLRKBYF	DK75-YVFM	Dilatation Expansion Joint With Tie Rods FM Approved Grooved $\pm 75$ mm Expansion
DKLRKBYF	DK100-YVFM	Dilatation Expansion Joint With Tie Rods FM Approved Grooved $\pm 100$ mm Expansion

## GENERAL

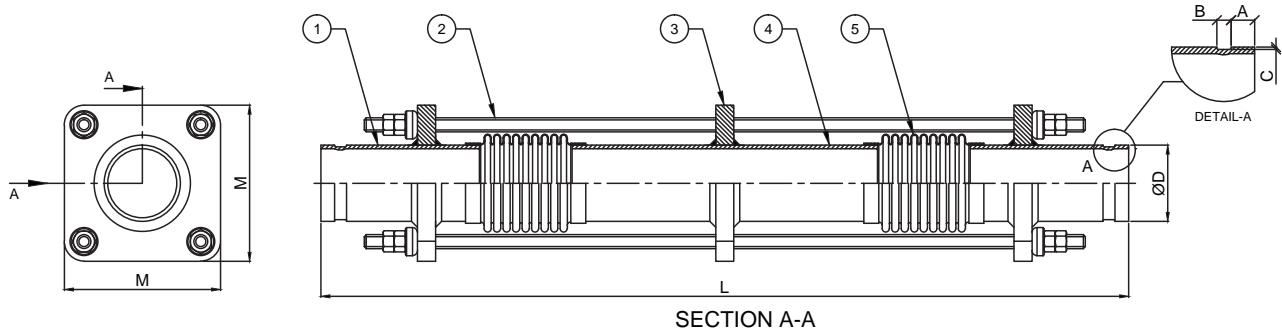
Dilatation expansion joints are the interconnection elements that ensure uninterrupted and efficient operation of the installation in the joints of buildings with different foundations (Dilatation), by absorbing strain and rupture that can occur in the pipelines due to building collapses or earthquakes, and lateral deviations. These types of expansion joints consisting of double bellows can be fixed to the desired expansion amounts by using limit rods. They can be used at all Dilatation points in building passages.



Standard Product Materials		Optional Product Materials
Bellows	1.4301 (AISI 304)	1.4541 / 1.4401 / Titanium / Incoloy 800H / Inconel etc.
Tie Rod Holders	1.0038 (St 37-2)	Stainless Steel
Grooved Connections	1.0038 (St 37-2)	Stainless Steel
Intermediate Pipe	1.0038 (St 37-2)	Stainless Steel

Design Parameters	
Design Pressure	250 psi
Design Temperature	+20°C (-90°C...+550°C)
Diameters	DN25 (1")...DN250 (10")
Movements	X: 60mm ( $\pm 30$ ), Y: 50mm ( $\pm 25$ ) / 100mm ( $\pm 50$ ) / 150mm ( $\pm 75$ ) / 200mm ( $\pm 100$ )
Standards	EJMA, EN 14917
Certifications	FM Approved - TSE - CE Module H (Optional) - EAC

\*\*Please contact our sales team for your special requests.



Part Number	Specifications	
	Name	Material
1	Grooved Connections	1.0038 (S235JR / St37-2)
2	Tie Rod	1.0038 (S235JR / St37-2)
3	Tie Rod Holder	1.0038 (S235JR / St37-2)
4	Intermediate Pipe	1.0038 (S235JR / St37-2)
5	Bellows	1.4301 (AISI 304)

Diameters		LENGTH (L = mm)				A (mm)	B (mm)	C (mm)	ØD (mm)	M (mm)	Effective Area (cm <sup>2</sup> )
		DKLRKBYF									
		DK25-YVFM	DK50-YVFM	DK75-YVFM	DK100-YVFM						
		X: ±30mm Y: ±25mm	X: ±30mm Y: ±50mm	X: ±30mm Y: ±75mm	X: ±30mm Y: ±100mm						
DN25	1"	550	650	750	850	15,8	7,1	1,6	33,7	111	19,0
DN32	1 1/4"	550	650	750	850	15,8	7,1	1,6	42,4	111	19,0
DN40	1 1/2"	550	650	750	850	15,8	7,1	1,6	48,3	111	24,7
DN50	2"	620	720	820	920	15,8	8,7	1,6	60,3	120	38,7
DN65	2 1/2"	620	720	820	920	15,8	8,7	1,9	76,1	156	58,0
DN80	3"	670	770	870	970	15,8	8,7	1,9	88,9	165	80,5
DN100	4"	670	770	870	970	15,8	8,7	2,1	114,3	183	129,0
DN125	5"	710	910	1010	1110	15,8	8,7	2,1	139,7	227	191,8
DN150	6"	710	910	1010	1110	15,8	8,7	2,1	165,1	247	262,7
DN200	8"	760	960	1050	1260	19,0	11,9	2,3	219,1	308	453,5
DN250	10"	860	1060	1150	1260	19,0	11,9	2,3	273	346	698,4

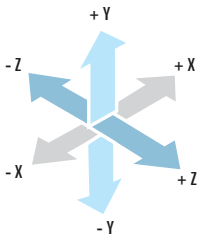
\*\* X,Y value represents axial, lateral movements. Please contact our technical department for different movement requirements.



Product Code	Definition
KM100-FDB	Seismic Isolation Expansion Joint Flanged $\pm 50$ mm Expansion
KM200-FDB	Seismic Isolation Expansion Joint Flanged $\pm 100$ mm Expansion
KM300-FDB	Seismic Isolation Expansion Joint Flanged $\pm 150$ mm Expansion
KM400-FDB	Seismic Isolation Expansion Joint Flanged $\pm 200$ mm Expansion

## GENERAL

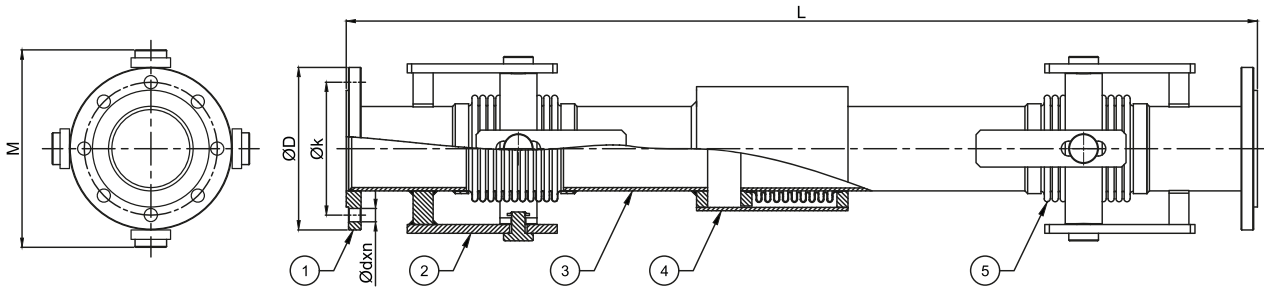
Seismic expansion joints are the flexible connection elements that minimize the risk of breakage that may occur in the system as a result of seismic (earthquake, building collapses, etc.) movements by damping the three dimensional movement as axial, lateral and angular and provide the continuity of the system by removing the stress on the rigid pipe. Seismic Expansion joints which are designed such as to accommodate the movement in three different directions (axial, lateral and angular), are widely used in systems such as heating, cooling, fire and sanitary systems of the structures where seismic isolators are used and the amount of movement is very high. They can also be used in places such as all building passages, Dilatation points etc. In the order phase, the prescribed amount of motion in the system, fluid type in the line, place of use, connection type, the working pressure and temperature of the system should be specified.



Standard Product Materials		Optional Product Materials
Bellows	1.4301 (AISI 304)	1.4541 / 1.4401 / Titanium / Incoloy 800H / Inconel etc.
Joint Arms	1.0038 (St 37-2)	Stainless Steel
Flanges	1.0038 (St 37-2)	Stainless Steel

Design Parameters	
Design Pressure	16 Bar (1 Bar...64 Bar)
Design Temperature	+20°C (-90°C...+550°C)
Diameters	DN25 (1")...DN2500 (100")
Movements	X: 100mm ( $\pm 50$ ); Y,Z: $\pm 50$ mm / Y,Z: $\pm 100$ mm / Y,Z: $\pm 150$ mm / Y,Z: $\pm 200$ mm
Standards	EJMA, EN 14917
Certifications	TSE - CE Module H (Optional) - EAC

\*\*Please contact our sales team for your special requests.



Part Number	Specifications	
	Name	Material
1	Flange	1.0038 (S235JR / St37-2)
2	Joint Arm	1.0038 (S235JR / St37-2)
3	Intermediate Pipe	1.0038 (S235JR / St37-2)
4	Outside Pipe	1.0038 (S235JR / St37-2)
5	Bellows	1.4301 (AISI 304)

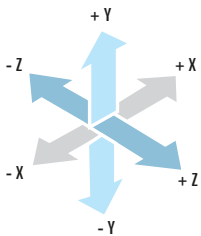
Diameters	LENGTH (L = mm)				ØD (mm)	Øk (mm)	Ødxn (mm)	M (mm)	Effective Area (cm²)	
	KM100-FDB	KM200-FDB	KM300-FDB	KM400-FDB						
	X: ±50mm Y: ±50mm Z: ±50mm	X: ±50mm Y: ±100mm Z: ±100mm	X: ±50mm Y: ±150mm Z: ±150mm	X: ±50mm Y: ±200mm Z: ±200mm						
DN25	1"	1290	1370	1470	1570	115	85	14*4	170	19,0
DN32	1 1/4"	1290	1370	1470	1570	140	100	18*4	170	19,0
DN40	1 1/2"	1270	1370	1470	1570	150	110	18*4	170	24,7
DN50	2"	1320	1420	1520	1620	165	125	18*4	195	38,7
DN65	2 1/2"	1400	1500	1600	1700	185	145	18*4	210	58,0
DN80	3"	1470	1570	1670	1770	200	160	18*8	220	80,5
DN100	4"	1550	1650	1750	1850	220	180	18*8	265	129,0
DN125	5"	1620	1720	1820	1920	250	210	18*8	310	191,8
DN150	6"	1645	1745	1845	1945	285	240	22*8	335	262,7
DN200	8"	1730	1830	1930	2030	340	295	22*12	425	453,5
DN250	10"	1820	1920	2020	2120	405	355	26*12	470	698,4
DN300	12"	1930	2030	2130	2230	460	410	26*12	570	967,0
DN350	14"	1950	2050	2150	2330	520	470	26*16	620	1149,6
DN400	16"	1995	2095	2195	2550	580	525	30*16	700	1517,7
DN450	18"	2030	2130	2350	2900	640	585	30*20	745	1884,2
DN500	20"	2030	2130	2550	3200	715	650	33*20	815	2282,5

\*\* X,Y,Z value represents axial, lateral, angular movements. Please contact our technical department for different movement requirements.  
\*\* Flange diameters are according to PN16 pressure class.

Product Code	Definition
KM100 - KBDB	Seismic Isolation Expansion Joint Welding Ends $\pm 50$ mm Expansion
KM200 - KBDB	Seismic Isolation Expansion Joint Welding Ends $\pm 100$ mm Expansion
KM300 - KBDB	Seismic Isolation Expansion Joint Welding Ends $\pm 150$ mm Expansion
KM400 - KBDB	Seismic Isolation Expansion Joint Welding Ends $\pm 200$ mm Expansion

## GENERAL

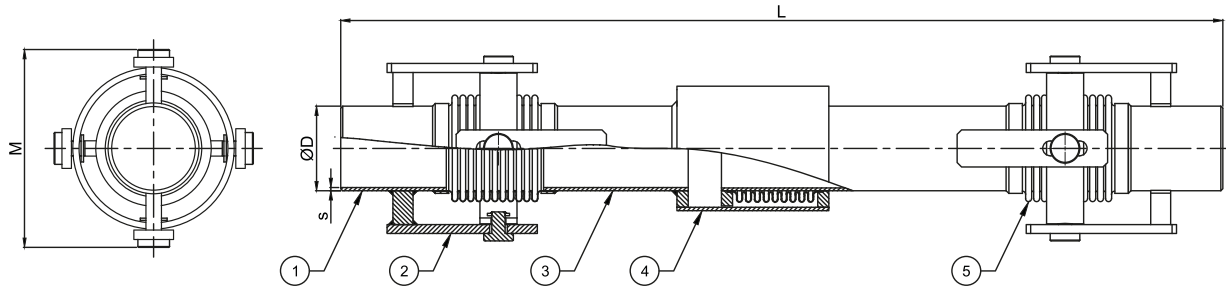
Seismic expansion joints are the flexible connection elements that minimize the risk of breakage that may occur in the system as a result of seismic (earthquake, building collapses, etc.) movements by damping the three dimensional movement as axial, lateral and angular and provide the continuity of the system by removing the stress on the rigid pipe. Seismic Expansion joints which are designed such as to accommodate the movement in three different directions (axial, lateral and angular), are widely used in systems such as heating, cooling, fire and sanitary systems of the structures where seismic isolators are used and the amount of movement is very high. They can also be used in places such as all building passages, Dilatation points etc. In the order phase, the prescribed amount of motion in the system, fluid type in the line, place of use, connection type, the working pressure and temperature of the system should be specified.



Standard Product Materials		Optional Product Materials
Bellows	1.4301 (AISI 304)	1.4541 / 1.4401 / Titanium / Incoloy 800H / Inconel etc.
Joint Arms	1.0038 (St 37-2)	Stainless Steel
Welding Ends	1.0038 (St 37-2)	Stainless Steel

Design Parameters	
Design Pressure	16 Bar (1 Bar...64 Bar)
Design Temperature	+20°C (+90°C...+550°C)
Diameters	DN25 (1")...DN2500 (100")
Movements	X:100mm ( $\pm 50$ ); Y,Z: $\pm 50$ mm / Y,Z: $\pm 100$ mm / Y,Z: $\pm 150$ mm / Y,Z: $\pm 200$ mm
Standards	EJMA, EN 14917
Certifications	TSE - CE Module H (Optional) - EAC

\*\*Please contact our sales team for your special requests.



Part Number	Specifications	
	Name	Material
1	Welding Ends	1.0038 (S235JR / St37-2)
2	Joint Arm	1.0038 (S235JR / St37-2)
3	Intermediate Pipe	1.0038 (S235JR / St37-2)
4	Outside Pipe	1.0038 (S235JR / St37-2)
5	Bellows	1.4301 (AISI 304)

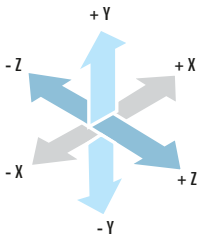
Diameters		LENGTH (L = mm)				ØD (mm)	s (mm)	M (mm)	Effective Area (cm <sup>2</sup> )
		KM100-KBDB	KM200-KBDB	KM300-KBDB	KM400-KBDB				
		X: ±50mm Y: ±50mm Z: ±50mm	X: ±50mm Y: ±100mm Z: ±100mm	X: ±50mm Y: ±150mm Z: ±150mm	X: ±50mm Y: ±200mm Z: ±200mm				
DN25	1"	1270	1350	1450	1550	33,7	3,2	170	19,0
DN32	1 1/4"	1270	1350	1450	1550	42,4	3,2	170	19,0
DN40	1 1/2"	1250	1350	1450	1550	48,3	3,2	170	24,7
DN50	2"	1300	1400	1500	1600	60,3	3,6	195	38,7
DN65	2 1/2"	1380	1480	1580	1680	76,1	3,6	210	58,0
DN80	3"	1450	1550	1650	1750	88,9	4	220	80,5
DN100	4"	1530	1630	1730	1830	114,3	4,5	265	129,0
DN125	5"	1600	1700	1800	1900	139,7	5	310	191,8
DN150	6"	1625	1725	1825	1925	165,1	5	335	262,7
DN200	8"	1710	1810	1910	2010	219,1	6,3	425	453,5
DN250	10"	1800	1900	2000	2100	273	6,3	470	698,4
DN300	12"	1900	2000	2100	2200	323,9	7,1	570	967,0
DN350	14"	1920	2020	2120	2300	355,6	8	620	1149,6
DN400	16"	1965	2065	2165	2520	406,4	8	700	1517,7
DN450	18"	2000	2100	2320	2870	457	8	745	1884,2
DN500	20"	2000	2100	2520	3170	508	8	815	2282,5

\*\* X,Y,Z value represents axial, lateral, angular movements. Please contact our technical department for different movement requirements.

Product Code	Definition
KM100 - YVDB	Seismic Isolation Expansion Joint Grooved $\pm 50$ mm Expansion
KM200 - YVDB	Seismic Isolation Expansion Joint Grooved $\pm 100$ mm Expansion
KM300 - YVDB	Seismic Isolation Expansion Joint Grooved $\pm 150$ mm Expansion
KM400 - YVDB	Seismic Isolation Expansion Joint Grooved $\pm 200$ mm Expansion

**GENERAL**

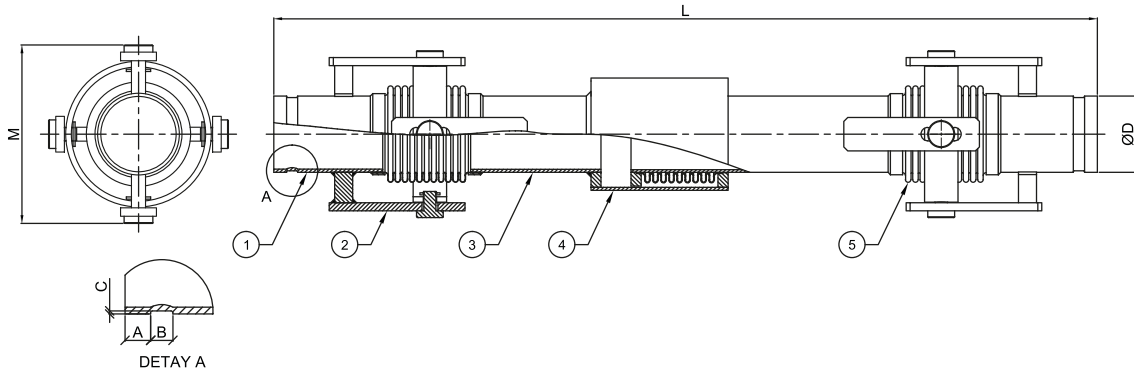
Seismic expansion joints are the flexible connection elements that minimize the risk of breakage that may occur in the system as a result of seismic (earthquake, building collapses, etc.) movements by damping the three dimensional movement as axial, lateral and angular and provide the continuity of the system by removing the stress on the rigid pipe. Seismic Expansion joints which are designed such as to accommodate the movement in three different directions (axial, lateral and angular), are widely used in systems such as heating, cooling, fire and sanitary systems of the structures where seismic isolators are used and the amount of movement is very high. They can also be used in places such as all building passages, Dilatation points etc. In the order phase, the prescribed amount of motion in the system, fluid type in the line, place of use, connection type, the working pressure and temperature of the system should be specified.



Standard Product Materials		Optional Product Materials	
Bellows	1.4301 (AISI 304)	1.4541 / 1.4401 / Titanium / Incoloy 800H / Inconel etc.	
Joint Arms	1.0038 (St 37-2)	Stainless Steel	
Grooved Connections	1.0038 (St 37-2)	Stainless Steel	

Design Parameters	
Design Pressure	16 Bar (1 Bar...64 Bar)
Design Temperature	+20°C (+90°C...+550°C)
Diameters	DN25 (1")...DN2500 (100")
Movements	X: 100mm ( $\pm 50$ ); Y,Z: $\pm 50$ mm / Y,Z: $\pm 100$ mm / Y,Z: $\pm 150$ mm / Y,Z: $\pm 200$ mm
Standards	EJMA, EN 14917
Certifications	TSE - CE Module H (Optional) - EAC

\*\*Please contact our sales team for your special requests.



Part Number	Specifications	
	Name	Material
1	Grooved End	1.0038 (S235JR / St37-2)
2	Joint Arm	1.0038 (S235JR / St37-2)
3	Intermediate Pipe	1.0038 (S235JR / St37-2)
4	Outside Pipe	1.0038 (S235JR / St37-2)
5	Bellows	1.4301 (AISI 304)

Diameters	LENGTH (L = mm)				A (mm)	B (mm)	C (mm)	ØD (mm)	M (mm)	Effective Area (cm²)	
	KM100-YVDB	KM200-YVDB	KM300-YVDB	KM400-YVDB							
	X: ±50mm Y: ±50mm Z: ±50mm	X: ±50mm Y: ±100mm Z: ±100mm	X: ±50mm Y: ±150mm Z: ±150mm	X: ±50mm Y: ±200mm Z: ±200mm							
DN25	1"	1270	1350	1450	1550	15,8	7,1	1,6	33,7	170	19,0
DN32	1 1/4"	1270	1350	1450	1550	15,8	7,1	1,6	42,4	170	19,0
DN40	1 1/2"	1250	1350	1450	1550	15,8	7,1	1,6	48,3	170	24,7
DN50	2"	1300	1400	1500	1600	15,8	8,7	1,6	60,3	195	38,7
DN65	2 1/2"	1380	1480	1580	1680	15,8	8,7	1,9	76,1	210	58,0
DN80	3"	1450	1550	1650	1750	15,8	8,7	1,9	88,9	220	80,5
DN100	4"	1530	1630	1730	1830	15,8	8,7	2,1	114,3	265	129,0
DN125	5"	1600	1700	1800	1900	15,8	8,7	2,1	139,7	310	191,8
DN150	6"	1625	1725	1825	1925	15,8	8,7	2,1	165,1	335	262,7
DN200	8"	1710	1810	1910	2010	19,0	11,9	2,3	219,1	425	453,5
DN250	10"	1800	1900	2000	2100	19,0	11,9	2,3	273	470	698,4
DN300	12"	1900	2000	2100	2200	19,0	11,9	2,7	323,9	570	967,0

\*\* X,Y,Z value represents axial, lateral, angular movements. Please contact our technical department for different movement requirements.

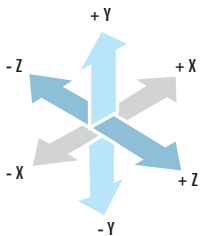


FM Code	Product Code	Definition
KYSUF	U100 - FFM	U-Flex Omega Loop Expansion Joint Flanged $\pm 50$ mm Expansion
KYSUF	U200 - FFM	U-Flex Omega Loop Expansion Joint Flanged $\pm 100$ mm Expansion

**GENERAL**

U-Flex expansion joints are intermediate parts used to dampen unexpected random dynamic loads that may come from the ground in seismic zones where seismic motion may be intense, to take stress on the line and to ensure the smooth operation of the system. They ensure the continuity of the line by protecting the boiler, chiller, fan coil units and fire sprinkler system by countering possible movements in any direction with the building.

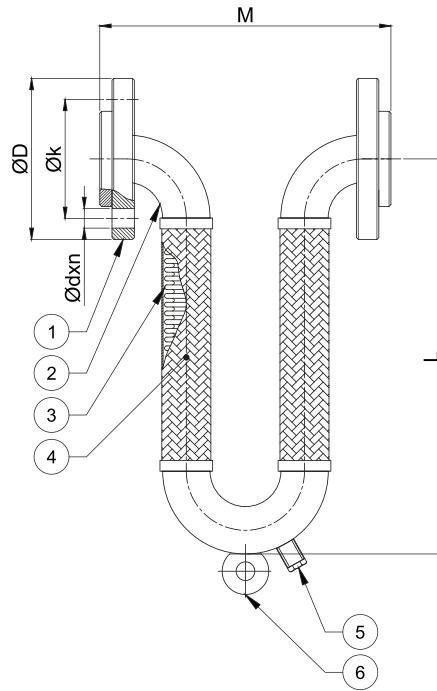
KAYSE Omega Type U-Flex omega loop expansion joints with FM Approved certificate eliminate breakage, cracking and crashes in the line, and ensure the continuity of fire, water and gas line in earthquake or building collapses.



Standard Product Materials		Optional Product Materials
Hose	1.4301 (AISI 304)	1.4541 (AISI 321)
Braid	1.4301 (AISI 304)	1.4301 (AISI 304)
Flanges	1.0038 (St 37-2)	Stainless Steel
Elbows	1.0038 (St 37-2)	Stainless Steel

Design Parameters	
Design Pressure	175 psi (Up to 250 psi)
Design Temperature	+20°C (+90°C...+550°C)
Diameters	DN25 (1")...DN250 (10")
Movements	100mm ( $\pm 50$ ) / 200mm ( $\pm 100$ )
Standards	EN, ANSI
Certifications	FM Approved - CE Module H (Optional)

\*\*Please contact our sales team for your special requests.



Part Number	Specifications	
	Name	Material
1	Flange	1.0038 (S235JR / St37-2)
2	90° Elbow	1.0038 (S235JR / St37-2)
3	Flex Metal Hose	1.4301 (AISI 304)
4	Braid	1.4301 (AISI 304)
5	Drain Plug	1.0038 (S235JR / St37-2)
6	Fixing Part	1.0038 (S235JR / St37-2)

Diameters		KYSUF				ØD (mm)	Øk (mm)	Ød x n (mm)
		U100-FFM		U200-FFM				
		X, Y, Z: ±50mm		X, Y, Z: ±100mm				
		M (mm)	L (mm)	M (mm)	L (mm)			
DN25	1"	254	375	254	500	115	85	14*4
DN32	1 1/4"	302	400	302	525	140	100	18*4
DN40	1 1/2"	340	425	340	575	140	110	18*4
DN50	2"	426	475	426	625	165	125	18*4
DN65	2 1/2"	522	525	522	700	185	145	18*4
DN80	3"	610	575	610	750	200	160	18*8
DN100	4"	792	700	792	875	220	180	18*8
DN125	5"	954	800	954	1000	250	210	18*8
DN150	6"	1106	925	1106	1150	285	240	22*8
DN200	8"	1432	1200	1432	1450	340	295	22*12
DN250	10"	1760	1702	1760	1981	405	355	26*12

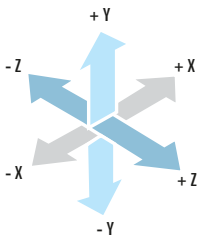
\*\* X,Y,Z value represents axial, lateral, angular movements. Please contact our technical department for different movement requirements.  
\*\* Flange diameters are according to PN16 pressure class.

FM Code	Product Code	Definition
KYSUKB	U100-KBFM	U-Flex Omega Loop Expansion Joint Welding Ends ±50mm Expansion
KYSUKB	U200-KBFM	U-Flex Omega Loop Expansion Joint Welding Ends ±100mm Expansion

**GENERAL**

U-Flex expansion joints are intermediate parts used to dampen unexpected random dynamic loads that may come from the ground in seismic zones where seismic motion may be intense, to take stress on the line and to ensure the smooth operation of the system. They ensure the continuity of the line by protecting the boiler, chiller, fan coil units and fire sprinkler system by countering possible movements in any direction with the building.

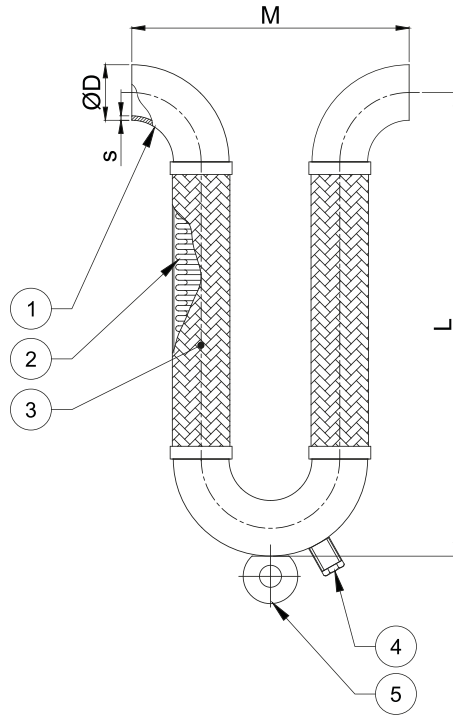
KAYSE Omega Type U-Flex omega loop expansion joints with FM Approved certificate eliminate breakage, cracking and crashes in the line, and ensure the continuity of fire, water and gas line in earthquake or building collapses.



Standard Product Materials		Optional Product Materials
Hose	1.4301 (AISI 304)	1.4541 (AISI 321)
Braid	1.4301 (AISI 304)	1.4301 (AISI 304)
Welding Ends	1.0038 (St 37-2)	Stainless Steel
Elbows	1.0038 (St 37-2)	Stainless Steel

Design Parameters	
Design Pressure	175 psi (Up to 250 psi)
Design Temperature	+20°C (+90°C...+550°C)
Diameters	DN25 (1")...DN250 (10")
Movements	100mm (±50) / 200mm (±100)
Standards	EN, ANSI
Certifications	FM Approved - CE Module H (Optional)

\*\*Please contact our sales team for your special requests.



Part Number	Specifications	
	Name	Material
1	90° Patent Elbow	1.0038 (S235JR / St37-2)
2	Flex Metal Hose	1.4301 (AISI 304)
3	Braid	1.4301 (AISI 304)
4	Drain Plug	1.0038 (S235JR / St37-2)
5	Fixing Part	1.0038 (S235JR / St37-2)

Diameters		KYSUKB				ØD (mm)	s (mm)
		U100-KBFM		U200-KBFM			
		X, Y, Z: ±50mm		X, Y, Z: ±100mm			
		M (mm)	L (mm)	M (mm)	L (mm)		
DN25	1"	152	375	152	500	33,7	2,6
DN32	1 1/4"	190	400	190	525	42,4	2,6
DN40	1 1/2"	228	425	228	575	48,3	2,6
DN50	2"	304	475	304	625	60,3	2,9
DN65	2 1/2"	380	525	380	700	76,1	2,9
DN80	3"	458	575	458	750	88,9	3,2
DN100	4"	610	700	610	875	114,3	3,6
DN125	5"	762	800	762	1000	139,7	4
DN150	6"	914	925	914	1150	168,3	4,5
DN200	8"	1220	1200	1220	1450	219,1	5,9
DN250	10"	1524	1702	1524	1981	273	6,3

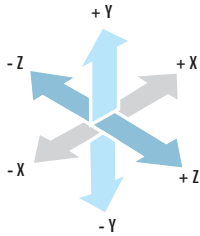
\*\* X,Y,Z value represents axial, lateral, angular movements. Please contact our technical department for different movement requirements.

FM Code	Product Code	Definition
KYSUY	U100- YVFM	U-Flex Omega Loop Expansion Joint Grooved ±50mm Expansion
KYSUY	U200- YVFM	U-Flex Omega Loop Expansion Joint Grooved ±100mm Expansion

**GENERAL**

U-Flex expansion joints are intermediate parts used to dampen unexpected random dynamic loads that may come from the ground in seismic zones where seismic motion may be intense, to take stress on the line and to ensure the smooth operation of the system. They ensure the continuity of the line by protecting the boiler, chiller, fan coil units and fire sprinkler system by countering possible movements in any direction with the building.

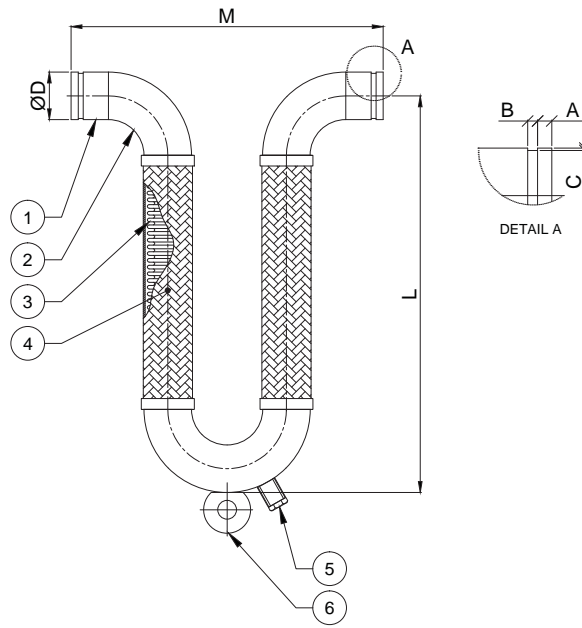
KAYSE Omega Type U-Flex omega loop expansion joints with FM Approved certificate eliminate breakage, cracking and crashes in the line, and ensure the continuity of fire, water and gas line in earthquake or building collapses.



Standard Product Materials		Optional Product Materials
Hose	1.4301 (AISI 304)	1.4541 (AISI 321)
Braid	1.4301 (AISI 304)	1.4301 (AISI 304)
Grooved Connections	1.0038 (St 37-2)	Stainless Steel
Elbows	1.0038 (St 37-2)	Stainless Steel

Design Parameters	
Design Pressure	250 psi
Design Temperature	+20°C (+90°C...+550°C)
Diameters	DN25 (1")...DN250 (10")
Movements	100mm (±50) / 200mm (±100)
Standards	EN, ANSI
Certifications	FM Approved - CE Module H (Optional)

\*\*Please contact our sales team for your special requests.



Part Number	Specifications	
	Name	Material
1	Grooved Connections	1.0038 (S235JR / St37-2)
2	90° Elbow	1.0038 (S235JR / St37-2)
3	Flex Metal Hose	1.4301 (AISI 304)
4	Braid	1.4301 (AISI 304)
5	Drain Plug	1.0038 (S235JR / St37-2)
6	Fixing Part	1.0038 (S235JR / St37-2)

Diameters		KYSUY				A (mm)	B (mm)	C (mm)	ØD (mm)
		U100-YVFM		U200-YVFM					
		X, Y, Z: ±50mm		X, Y, Z: ±100mm					
		M (mm)	L (mm)	M (mm)	L (mm)				
DN25	1"	242	375	242	500	15,8	7,1	1,6	33,7
DN32	1 1/4"	290	400	290	525	15,8	7,1	1,6	42,4
DN40	1 1/2"	328	425	328	575	15,8	7,1	1,6	48,3
DN50	2"	414	475	414	625	15,8	8,7	1,6	60,3
DN65	2 1/2"	510	525	510	700	15,8	8,7	1,9	76,1
DN80	3"	598	575	598	750	15,8	8,7	1,9	88,9
DN100	4"	780	700	780	875	15,8	8,7	2,1	114,3
DN125	5"	942	800	942	1000	15,8	8,7	2,1	139,7
DN150	6"	1094	925	1094	1150	15,8	8,7	2,1	168,3
DN200	8"	1420	1200	1420	1450	19,0	11,9	2,3	219,1
DN250	10"	1724	1702	1724	1981	19,0	11,9	2,3	273

\*\* X,Y,Z value represents axial, lateral, angular movements. Please contact our technical department for different movement requirements.

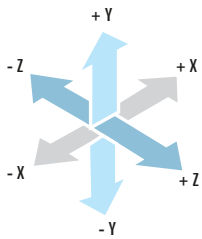


FM Code	Product Code	Definition
KYSUD	U100-DFM	U-Flex Omega Loop Expansion Joint Threaded ±50mm Expansion
KYSUD	U200-DFM	U-Flex Omega Loop Expansion Joint Threaded ±100mm Expansion

**GENERAL**

U-Flex expansion joints are intermediate parts used to dampen unexpected random dynamic loads that may come from the ground in seismic zones where seismic motion may be intense, to take stress on the line and to ensure the smooth operation of the system. They ensure the continuity of the line by protecting the boiler, chiller, fan coil units and fire sprinkler system by countering possible movements in any direction with the building.

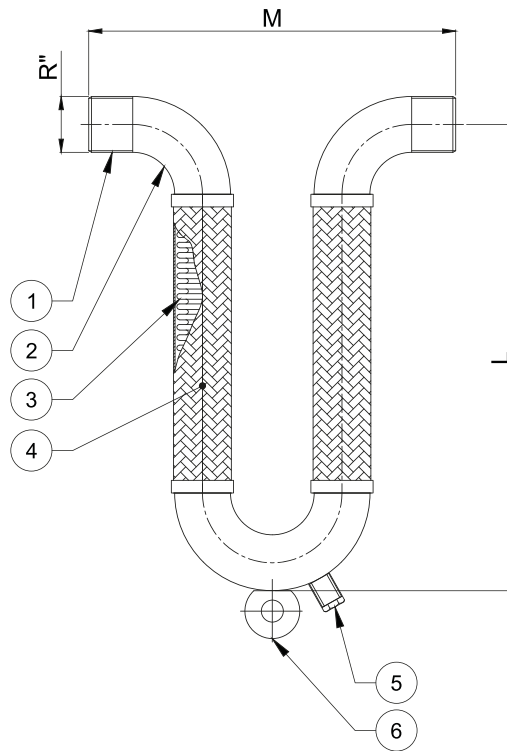
KAYSE Omega Type U-Flex omega loop expansion joints with FM Approved certificate eliminate breakage, cracking and crashes in the line, and ensure the continuity of fire, water and gas line in earthquake or building collapses.



Standard Product Materials		Optional Product Materials
Hose	1.4301 (AISI 304)	1.4541 (AISI 321)
Braid	1.4301 (AISI 304)	1.4301 (AISI 304)
Threaded Connections	1.0038 (St 37-2)	Stainless Steel
Elbows	1.0038 (St 37-2)	Stainless Steel

Design Parameters	
Design Pressure	250 psi
Design Temperature	+20°C (+90°C...+550°C)
Diameters	DN25 (1")...DN250 (10")
Movements	100mm (±50) / 200mm (±100)
Standards	EN, ANSI
Certifications	FM Approved - CE Module H (Optional)

\*\*Please contact our sales team for your special requests.



Part Number	Specifications	
	Name	Material
1	Threaded Connection	1.0038 (S235JR / St37-2)
2	90° Elbow	1.0038 (S235JR / St37-2)
3	Flex Metal Hose	1.4301 (AISI 304)
4	Braid	1.4301 (AISI 304)
5	Drain Plug	1.0038 (S235JR / St37-2)
6	Fixing Part	1.0038 (S235JR / St37-2)

Diameters	KYSUD			
	U100-DFM		U200-DFM	
	X, Y, Z: ±50mm		X, Y, Z: ±100mm	
	M (mm)	L (mm)	M (mm)	L (mm)
1"	242	375	242	500
1 1/4"	290	400	290	525
1 1/2"	328	425	328	575
2"	414	475	414	625
2 1/2"	510	525	510	700
3"	598	575	598	750
4"	780	700	780	875

\*\* X,Y,Z value represents axial movement. Please contact our technical department for different expansion requirements.

During earthquake it would not be possible to predict the direction of the movement with certainty therefore it would be possible to observe axial distancing, parallel movement, frontal collapse at dilatation points of two buildings with different foundations, as shown belows. With the omega application that is widely used in the world, all the movements can be taken under control and the continuity of the system can be ensured.



Standart Position



Thermal Compression



Thermal Expansion



All Directional Seismic Movement



Axial Compression & Extension



Parallel Offset with "X" Axis Rotation



Parallel Offset with "Z" Axis Rotation



Parallel Offset with "Y" Axis Rotation



Horizontal Connection



Vertical Connection



Vertical Connection



Parallel Connection



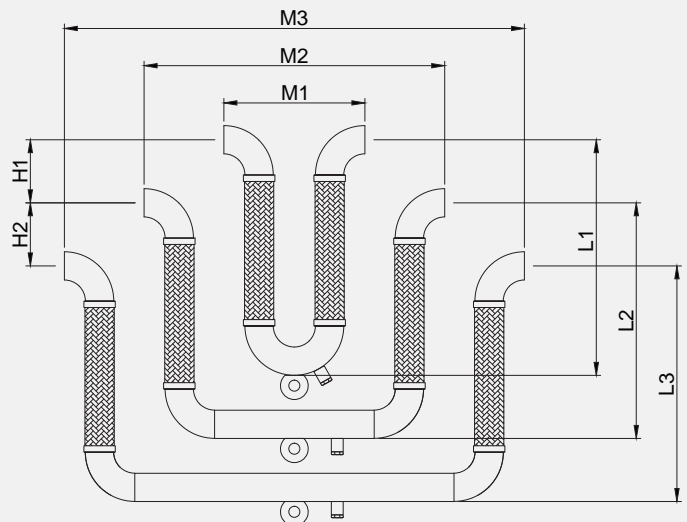
Storage Tanks



Fire Dilatation Transition

### MULTIPLE OMEGA U-FLEX APPLICATIONS

Omega Type U-Flex can be mounting by flange, thread, cut grooved, welded on the multiple installations application L, M, H distances determined before ordering notify values of X, Y, Z movement system pressure and temperature.

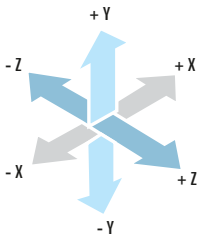


FM Code	Product Code	Definition
KYSVF	V100-FFM	V-Flex Omega Loop Expansion Joint Flanged ±50mm Expansion
KYSVF	V200-FFM	V-Flex Omega Loop Expansion Joint Flanged ±100mm Expansion

**GENERAL**

V-Flex expansion joints are intermediate parts used to dampen unexpected random dynamic loads that may come from the ground in seismic zones where seismic motion may be intense, to take stress on the line and to ensure the smooth operation of the system. They ensure the continuity of the line by protecting the boiler, chiller, fan coil units and fire sprinkler system by countering possible movements in any direction with the building.

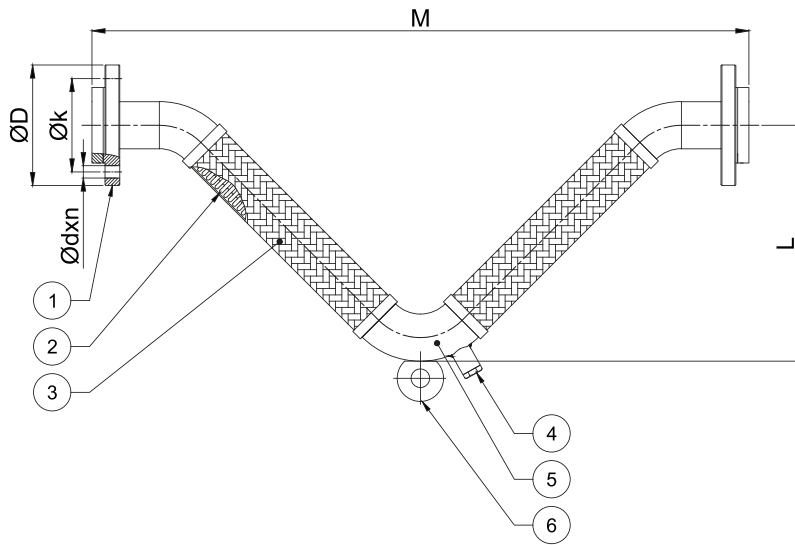
KAYSE Omega Type V-Flex omega loop expansion joints with FM Approved certificate eliminate breakage, cracking and crashes in the line, and ensure the continuity of fire, water and gas line in earthquake or building collapses.



Standard Product Materials		Optional Product Materials	
Hose	1.4301 (AISI 304)	1.4541 (AISI 321)	
Braid	1.4301 (AISI 304)	1.4301 (AISI 304)	
Flanges	1.0038 (St 37-2)	Stainless Steel	
Elbows	1.0038 (St 37-2)	Stainless Steel	

Design Parameters	
Design Pressure	250 psi
Design Temperature	+20°C (-90°C...+550°C)
Diameters	DN25 (1")...DN250 (10")
Movements	100mm (±50) / 200mm (±100)
Standards	EN, ANSI
Certifications	FM Approved - CE Module H (Optional)

\*\*Please contact our sales team for your special requests.



Part Number	Specifications	
	Name	Material
1	Flange	1.0038 (S235JR / St37-2)
2	Flex Metal Hose	1.4301 (AISI 304)
3	Braid	1.4301 (AISI 304)
4	Drain Plug	1.0038 (S235JR / St37-2)
5	90° Elbow	1.0038 (S235JR / St37-2)
6	Fixing Part	1.0038 (S235JR / St37-2)

Diameters		KYSVF				ØD (mm)	Øk (mm)	Ød x n (mm)
		V100-FFM		V200-FFM				
		X, Y, Z: ±50mm		X, Y, Z: ±100mm				
		M (mm)	L (mm)	M (mm)	L (mm)			
DN25	1"	609	239	761	315	115	85	14*4
DN32	1 1/4"	676	264	854	353	140	100	18*4
DN40	1 1/2"	800	321	966	404	150	110	18*4
DN50	2"	868	340	1097	455	165	125	18*4
DN65	2 1/2"	1044	410	1283	530	185	145	18*4
DN80	3"	1262	505	1428	588	200	160	18*8
DN100	4"	1392	536	1570	625	220	180	18*8
DN125	5"	1695	663	1733	682	250	210	18*8
DN150	6"	1894	746	2022	810	285	240	22*8
DN200	8"	2168	835	2358	930	340	295	22*12
DN250	10"	2541	986	2683	1056	405	355	26*12

\*\* X,Y,Z value represents axial, lateral, angular movements. Please contact our technical department for different movement requirements.

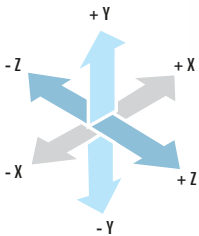
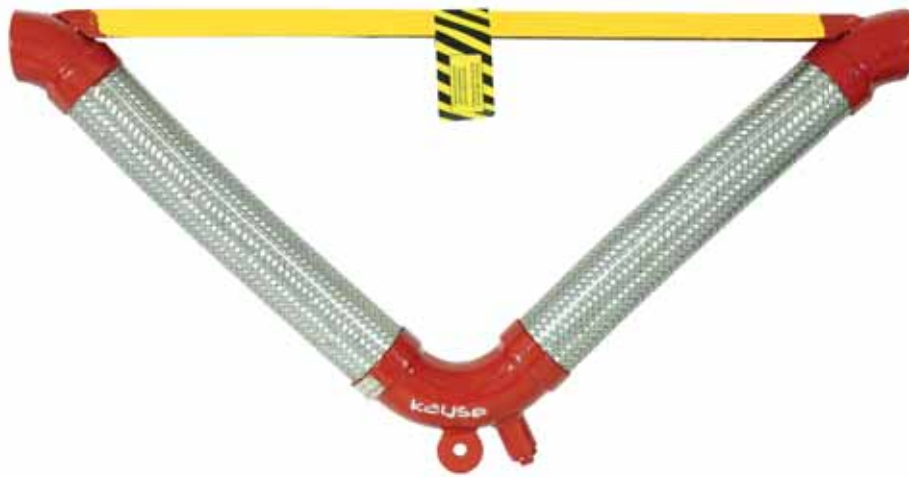
\*\* Flange diameters are according to PN16 pressure class.

FM Code	Product Code	Definition
KYSVKB	V100-KBFM	V-Flex Omega Loop Expansion Joint Welding Ends ±50mm Expansion
KYSVKB	V200-KBFM	V-Flex Omega Loop Expansion Joint Welding Ends ±100mm Expansion

**GENERAL**

V-Flex expansion joints are intermediate parts used to dampen unexpected random dynamic loads that may come from the ground in seismic zones where seismic motion may be intense, to take stress on the line and to ensure the smooth operation of the system. They ensure the continuity of the line by protecting the boiler, chiller, fan coil units and fire sprinkler system by countering possible movements in any direction with the building.

KAYSE Omega Type V-Flex omega loop expansion joints with FM Approved certificate eliminate breakage, cracking and crashes in the line, and ensure the continuity of fire, water and gas line in earthquake or building collapses.

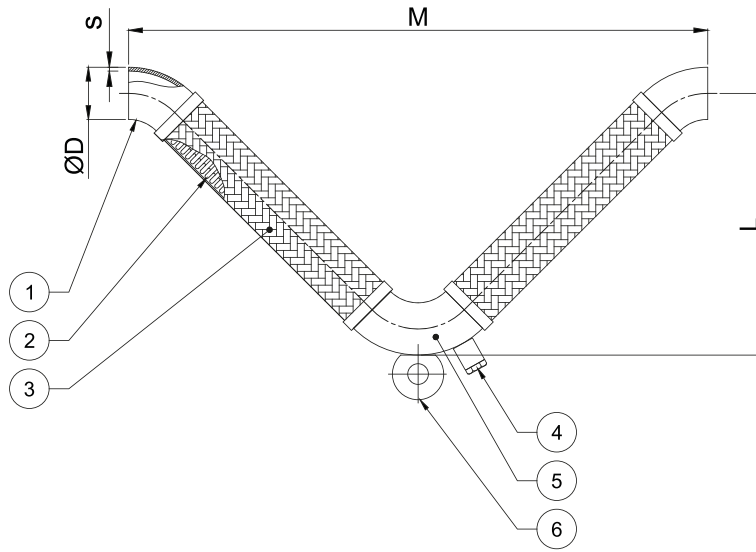


Standard Product Materials		Optional Product Materials
Hose	1.4301 (AISI 304)	1.4541 (AISI 321)
Braid	1.4301 (AISI 304)	1.4301 (AISI 304)
Welding Ends	1.0038 (St 37-2)	Stainless Steel
Elbows	1.0038 (St 37-2)	Stainless Steel

Design Parameters	
Design Pressure	250 psi
Design Temperature	+20°C (-90°C...+550°C)
Diameters	DN25 (1")...DN250 (10")
Movements	100mm (±50) / 200mm (±100)
Standards	EN, ANSI
Certifications	FM Approved - CE Module H (Optional)

\*\*Please contact our sales team for your special requests.





Part Number	Specifications	
	Name	Material
1	Welding Ends	1.0038 (S235JR / St37-2)
2	Flex Metal Hose	1.4301 (AISI 304)
3	Braid	1.4301 (AISI 304)
4	Drain Plug	1.0038 (S235JR / St37-2)
5	90° Elbow	1.0038 (S235JR / St37-2)
6	Fixing Part	1.0038 (S235JR / St37-2)

Diameters		KYSVKB				ØD (mm)	s (mm)
		V100-KBFM		V200-KBFM			
		X, Y, Z: ±50mm		X, Y, Z: ±100mm			
		M (mm)	L (mm)	M (mm)	L (mm)		
DN25	1"	507	239	659	315	33,7	2,6
DN32	1 1/4"	564	264	742	353	42,4	2,6
DN40	1 1/2"	689	321	854	404	48,3	2,6
DN50	2"	746	340	975	455	60,3	2,9
DN65	2 1/2"	902	410	1141	530	76,1	2,9
DN80	3"	1110	505	1277	588	88,9	3,2
DN100	4"	1210	536	1388	625	114,3	3,6
DN125	5"	1503	663	1541	682	139,7	4,0
DN150	6"	1702	746	1830	810	165,1	4,5
DN200	8"	1956	835	2146	930	219,1	5,9
DN250	10"	2329	986	2471	1056	273	6,3

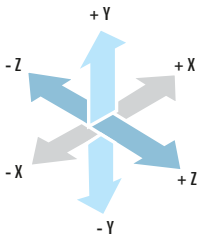
\*\* X,Y,Z value represents axial, lateral, angular movements. Please contact our technical department for different movement requirements.

FM Code	Product Code	Definition
KYSVY	V100 - YVFM	V-Flex Omega Loop Expansion Joint Grooved ±50mm Expansion
KYSVY	V200 - YVFM	V-Flex Omega Loop Expansion Joint Grooved ±100mm Expansion

**GENERAL**

V-Flex expansion joints are intermediate parts used to dampen unexpected random dynamic loads that may come from the ground in seismic zones where seismic motion may be intense, to take stress on the line and to ensure the smooth operation of the system. They ensure the continuity of the line by protecting the boiler, chiller, fan coil units and fire sprinkler system by countering possible movements in any direction with the building.

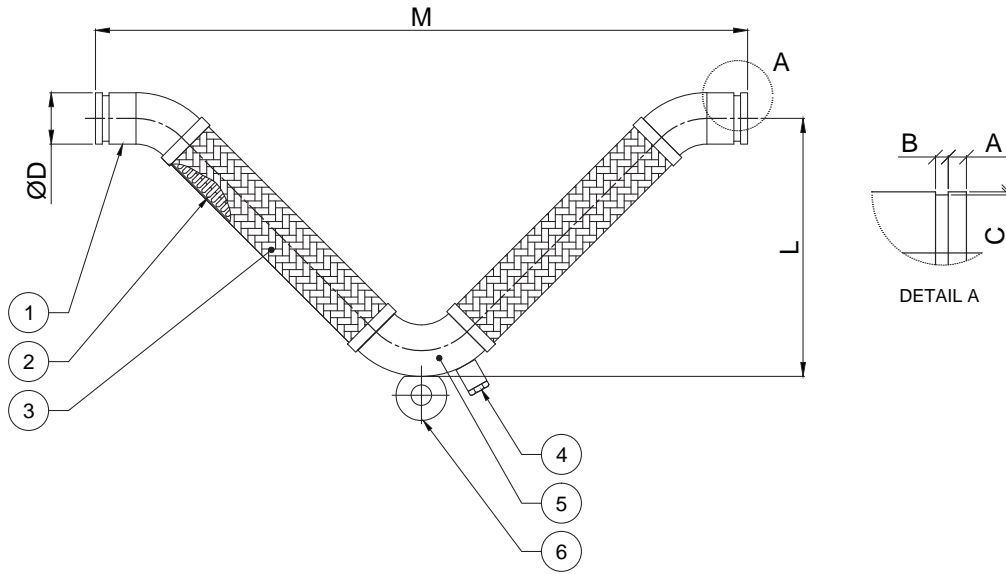
KAYSE Omega Type V-Flex omega loop expansion joints with FM Approved certificate eliminate breakage, cracking and crashes in the line, and ensure the continuity of fire, water and gas line in earthquake or building collapses.



Standard Product Materials		Optional Product Materials
Hose	1.4301 (AISI 321)	1.4541 (AISI 321)
Braid	1.4301 (AISI 304)	1.4301 (AISI 304)
Grooved Connections	1.0038 (St 37-2)	Stainless Steel
Elbows	1.0038 (St 37-2)	Stainless Steel

Design Parameters	
Design Pressure	250 psi
Design Temperature	+20°C (-90°C...+550°C)
Diameters	DN25 (1")...DN250 (10")
Movements	100mm (±50) / 200mm (±100)
Standards	EN, ANSI
Certifications	FM Approved - CE Module H (Optional)

\*\*Please contact our sales team for your special requests.



Part Number	Specifications	
	Name	Material
1	Grooved Connections	1.0038 (S235JR / St37-2)
2	Flex Metal Hose	1.4301 (AISI 304)
3	Braid	1.4301 (AISI 304)
4	Drain Plug	1.0038 (S235JR / St37-2)
5	90° Elbow	1.0038 (S235JR / St37-2)
6	Fixing Part	1.0038 (S235JR / St37-2)

Diameters		KYSVY				A (mm)	B (mm)	C (mm)	ØD (mm)
		V100-YVFM		V200-YVFM					
		X, Y, Z: ±50mm		X, Y, Z: ±100mm					
		M (mm)	L (mm)	M (mm)	L (mm)				
DN25	1"	597	239	749	315	15,8	7,1	1,6	33,7
DN32	1 1/4"	664	264	842	353	15,8	7,1	1,6	42,4
DN40	1 1/2"	789	321	954	404	15,8	7,1	1,6	48,3
DN50	2"	856	340	1085	455	15,8	8,7	1,6	60,3
DN65	2 1/2"	1032	410	1271	530	15,8	8,7	1,9	76,1
DN80	3"	1250	505	1416	588	15,8	8,7	1,9	88,9
DN100	4"	1380	536	1558	625	15,8	8,7	2,1	114,3
DN125	5"	1683	663	1721	682	15,8	8,7	2,1	139,7
DN150	6"	1882	746	2010	819	15,8	8,7	2,1	165,1
DN200	8"	2156	835	2346	930	19,0	11,9	2,3	219,1
DN250	10"	2529	986	2671	1056	19,0	11,9	2,3	273

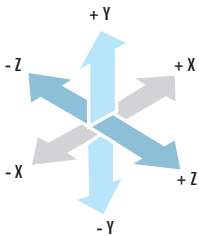
\*\* X,Y,Z value represents axial, lateral, angular movements. Please contact our technical department for different movement requirements.

FM Code	Product Code	Definition
KYSVD	V100- DFM	V-Flex Omega Loop Expansion Joint Threaded ±50mm Expansion
KYSVD	V200- DFM	V-Flex Omega Loop Expansion Joint Threaded ±100mm Expansion

**GENERAL**

V-Flex expansion joints are intermediate parts used to dampen unexpected random dynamic loads that may come from the ground in seismic zones where seismic motion may be intense, to take stress on the line and to ensure the smooth operation of the system. They ensure the continuity of the line by protecting the boiler, chiller, fan coil units and fire sprinkler system by countering possible movements in any direction with the building.

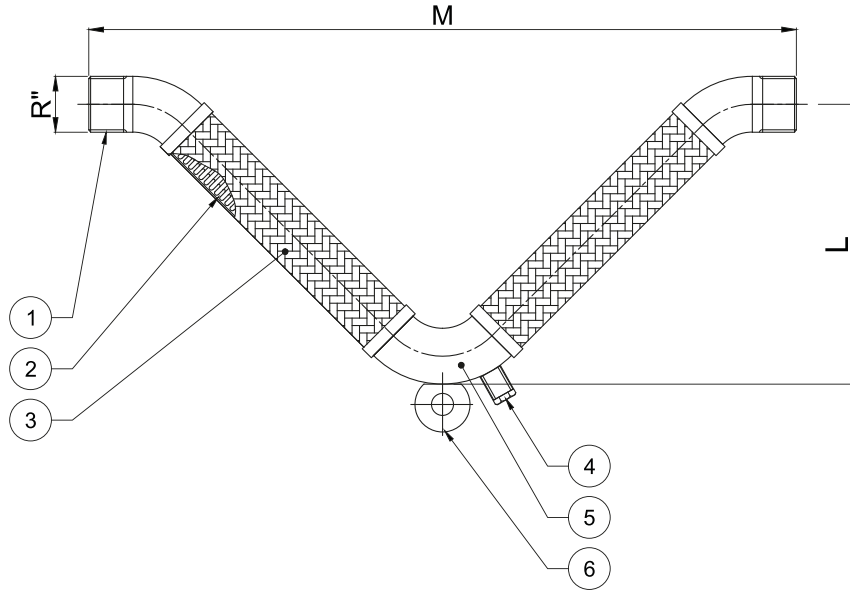
KAYSE Omega Type V-Flex omega loop expansion joints with FM Approved certificate eliminate breakage, cracking and crashes in the line, and ensure the continuity of fire, water and gas line in earthquake or building collapses.



Standard Product Materials		Optional Product Materials
Hose	1.4301 (AISI 304)	1.4541 (AISI 321)
Braid	1.4301 (AISI 304)	1.4301 (AISI 304)
Threaded Connections	1.0038 (St 37-2)	Stainless Steel
Elbows	1.0038 (St 37-2)	Stainless Steel

Design Parameters	
Design Pressure	250 psi
Design Temperature	+20°C (-90°C...+550°C)
Diameters	DN25 (1")...DN250 (10")
Movements	100mm (±50) / 200mm (±100)
Standards	EN, ANSI
Certifications	FM Approved - CE Module H (Optional)

\*\*Please contact our sales team for your special requests.

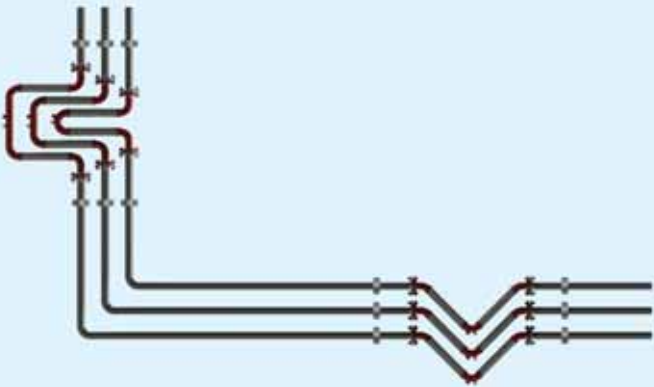


Part Number	Specifications	
	Name	Material
1	Threaded Connections	1.0038 (S235JR / St37-2)
2	Flex Metal Hose	1.4301 (AISI 304)
3	Braid	1.4301 (AISI 304)
4	Drain Plug	1.0038 (S235JR / St37-2)
5	90° Elbow	1.0038 (S235JR / St37-2)
6	Fixing Part	1.0038 (S235JR / St37-2)

Diameters	KYSVD			
	V100-DFM		V200-DFM	
	X, Y, Z: ±50mm		X, Y, Z: ±100mm	
	M (mm)	L (mm)	M (mm)	L (mm)
1"	597	239	749	315
1 1/4"	664	264	842	353
1 1/2"	789	321	954	404
2"	856	340	1085	455
2 1/2"	1032	410	1271	530
3"	1250	505	1416	588
4"	1380	536	1558	625

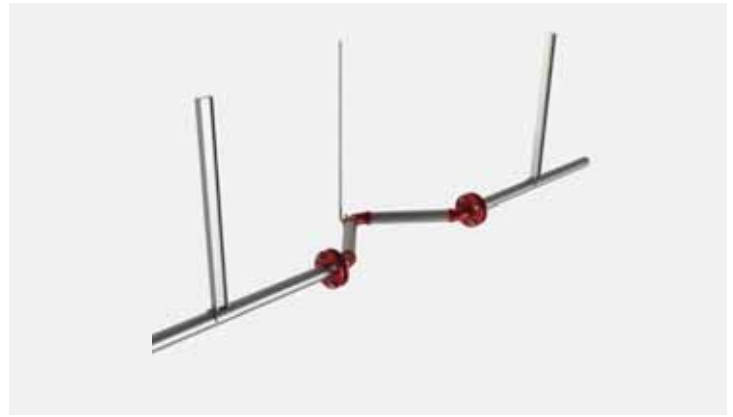
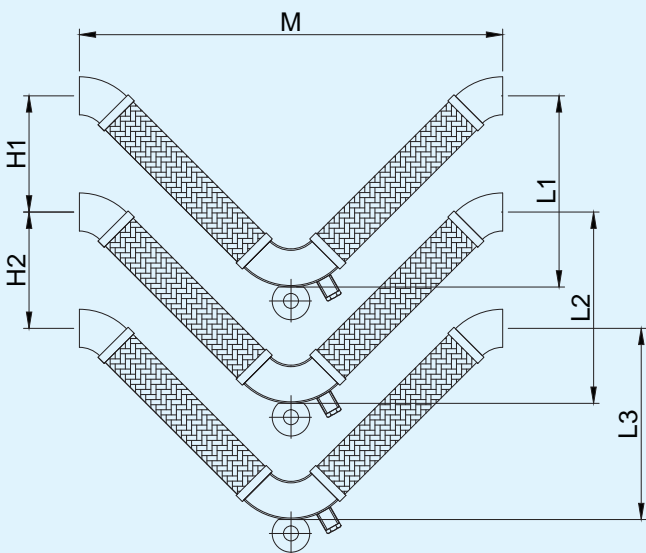
\*\* X,Y,Z represents axial, lateral, angular expansion values. Please contact our technical department for different expansion requirements.

During earthquake it would not be possible to predict the direction of the movement with certainty therefore it would be possible to observe axial distancing, parallel movement, frontal collapse at dilatation points of two buildings with different foundations, as shown bellows. With the omega application that is widely used in the world, all the movements can be taken under control and the continuity of the system can be ensured.



**MULTIPLE OMEGA V-FLEX APPLICATIONS**

Omega Type V-Flex can be mounting by flange, thread, cut grooved, welded on the multiple installations application L, M, H distances determined before ordering notify values of X, Y, Z movement system pressure and temperature.



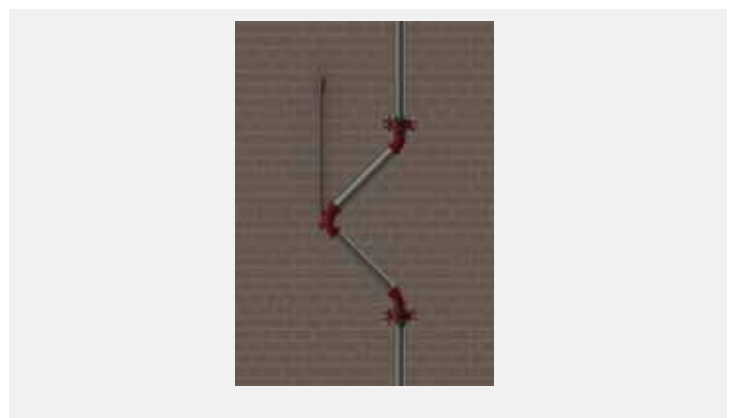
Horizontal Connection



Vertical Connection



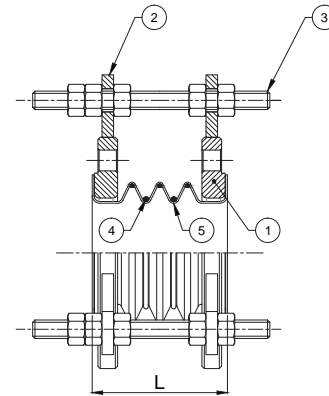
Vertical Connection



Vertical Connection

**Technical Specifications**

- DN25...-DN2200 diameters,
- Improved special design for highly corrosive fluids(hydrochloric acid, nitric acid, liquid chlorine, sulfuric acid etc.),
- Rigid working opportunity with cast steel body,
- Minimum 3mm teflon coating on stainless steel,
- Better leak proofing and ease of assembly with wider sealing surface,
- Better maintenance with two part body,
- 100% leak test before delivery,,
- Manufacturing in DIN and ANSI norms.



**Application Areas**

- Chemical and petrochemical plants,
- Chlorine-Alkali plants,
- Hydrochloric / Sulfuric acid etc. corrosive applications,
- Fertilizer factories,
- Mining industry,
- Ship industry

Part Number	Specifications	
	Name	Material
1	Flange	1.0038 (S235JR / St 37-2)
2	Tie-Rod Holder	1.0038 (S235JR / St 37-2)
3	Tie-Rod	1.0038 (S235JR / St 37-2)
4	Reinforce Ring	Stainless Steel
5	Bellows	Teflon (Min. 3mm)

Materials		Design Parameters	
Bellows	PTFE (Teflon)	Design Pressure	0,03...-0,4 MPa
Flanges	Cast steel, Stainless Steel	Diameters	DN25...-DN2200
Clack	Stainless Steel	Design Standards	DIN, ANSI

DN	L (mm)	Axial Movement (mm)	Lateral Movement ΔY (mm)	Angular Movement ΔΘ (mm)	Nominal Pressure (bar)
25	100	± 15	8	25	4 / -0,9
32	100	± 15	10	25	4 / -0,9
40	100	± 18	14	25	4 / -0,9
50	100	± 18	15	25	4 / -0,9
65	110	± 20	16	25	3,5 / -0,9
80	120	± 20	16	25	3,5 / -0,9
100	120	± 25	17	20	3 / -0,9
125	130	± 27	17	18	3 / -0,9
150	140	± 27	16	15	3 / -0,9
200	150	± 27	15	13	2,5 / -0,9
250	160	± 27	12	10	2,5 / -0,9
300	170	± 27	8	5,5	2,5 / -0,9

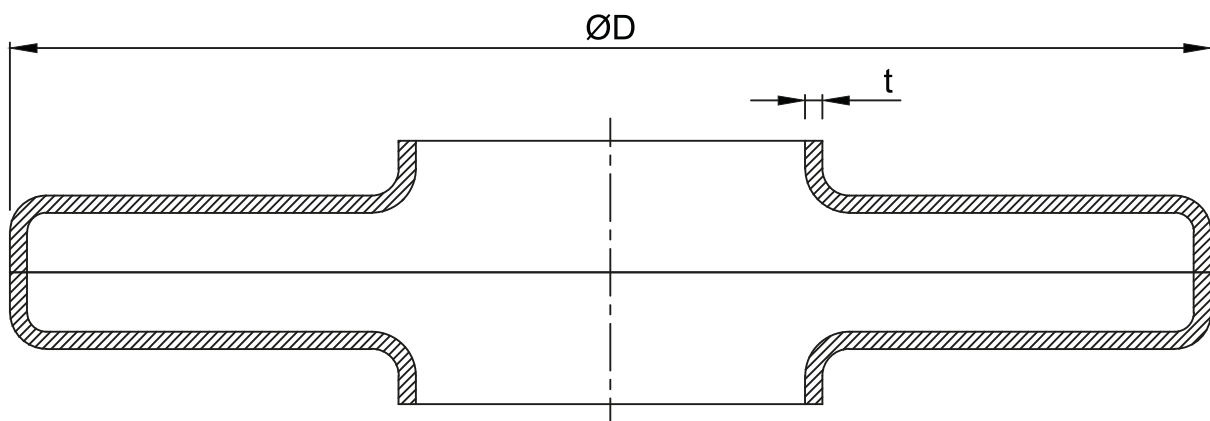




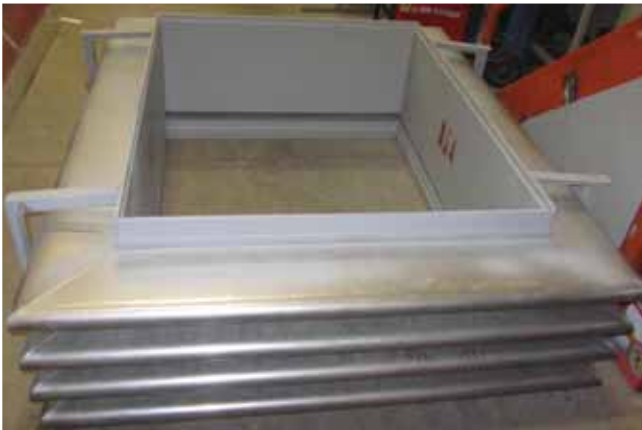
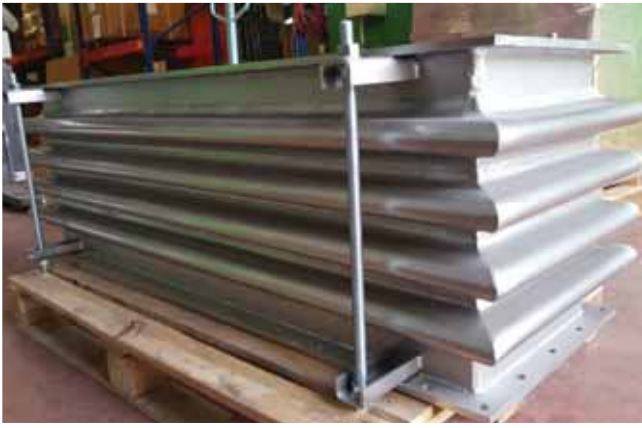
Lens type expansion joints are used in single layer bellows and applications where a single layer should be greater than 3-4mm. Standard bellows are no longer available if a single bellows layer must be greater than 3-4mm. In such cases, lens expansion joints will provide the best solution. Corrosion resistance is very high in lens type expansion joints since their bellows thickness is higher than that of standard bellows. Unlike standard bellows, they can be welded on site for repair. They are long-lasting due to their high bending (joint) depth and high bellows thickness.

### Specifications

Diameters (ØD)	Ø600mm...Ø8500mm
Thickness (t)	3mm...80mm
Material	1.0037 / 1.4541 / 1.4401 / Titanium / Incoloy 800H etc.



\*\*Please contact our sales team for your customized demands.

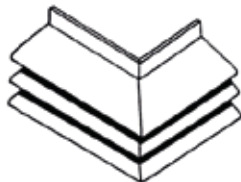


Rectangular expansion joints are designed to absorb axial, lateral, and angular motions. Rectangular bellows are mainly used in very low-pressure applications such as ducts, exhaust systems, ventilation systems, etc. Rectangular expansion joints, which are used in applications with high lateral motions, are manufactured using two separate bellows with the same characteristics. Fittings and bellows are available in various materials, sizes, and corner structures to meet customer requirements.

**CORNER TYPES**



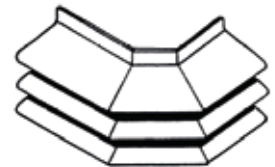
Round Corner



Single Mitre Corner



Camera Corner



Double Mitre (Corner)

**Specifications**

LENGTHutlar	It can be manufactured in desired dimensions according to the place and purpose of use.
Connection	Rectangular flange or welded manufacturing can be provided.
Materials	1.0038 / 1.4541 / 1.4401 / Titanium / Incoloy 800H vb.

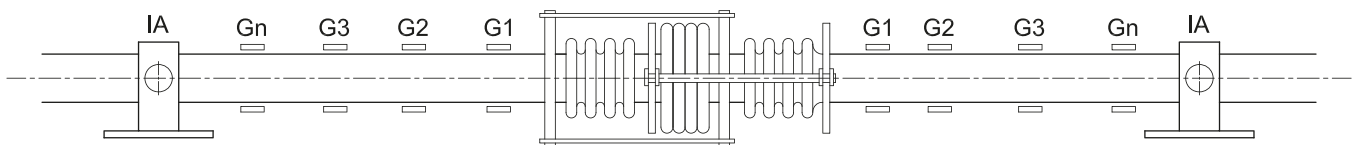
\*\*Please contact our sales team for your special requests.



Pressure balanced expansion joints are used to absorb axial and lateral motions and eliminate the pressure thrust resulting from the bellows. An additional bellows is placed in the main body of the expansion joint and it is subjected to line pressure to produce a force equal to and opposite to the main bellows. Using the limit rods used, the pressure thrust to be formed is neutralized within the expansion joint itself. They are particularly used when the fixed-point application is not possible. They are manufactured in two different types as In-Line and Elbow.

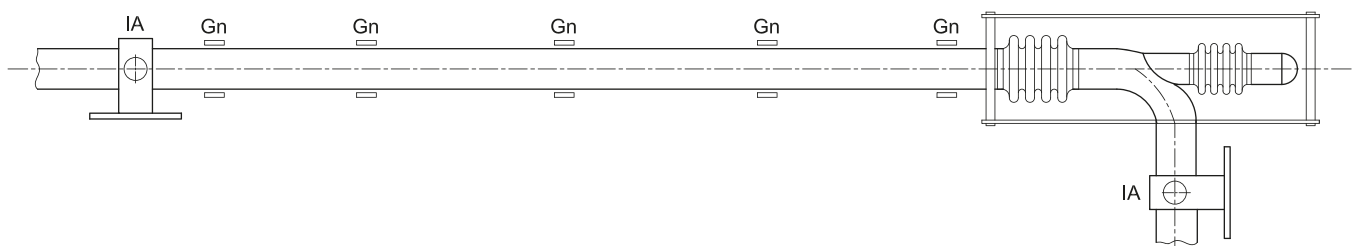
### 1- In-Line Pressure Balanced Expansion Joints

In straight pipelines, In-Line type pressure balanced axial expansion joints are placed between two intermediate bearings. These expansion joints can absorb axial movement without applying pressure load to the bearings.



### 2- Elbow Type Pressure Balanced Expansion Joints

If there is a deflection on a pipeline, the pressure balanced axial expansion joints can be used to absorb motion without loading pressure thrust to the intermediate bearings or end fittings.



#### Material / Specifications

Bellows	1.4301 / 1.4541 / 1.4401 / Titanium / Incoloy 800H / Incoloy 625 / Incoloy 825 / Inconel vb.
Inside / Outside Pipe	1.0038 (S235JR) / Stainless Steel
Connection	1.0038 (S235JR) / Stainless Steel

\*\*Please contact our sales team for your customized demands.

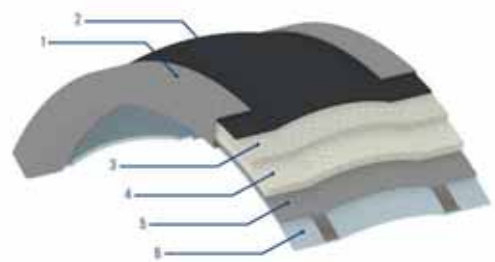
Fabric expansion joints are manufactured using highly flexible and specially selected woven fabrics. Fabric expansion joints are used to prevent mechanical loads, protect against abrasion, isolate excessive vibration and noise. Fabric expansion joints, which are easy to handle and assemble, can easily absorb expansion in different directions as well as mechanical torsion, unlike other expansion joints types. Fabric expansion joints are installed in systems operating in low pressure and dry environments.



### APPLICATION AREAS

Fabric expansion joints have a wide range of application areas

- Iron and Steel Industry
- Chemical industry
- Refineries
- Cement Industry
- Power Plants
- Shipbuilding Industry



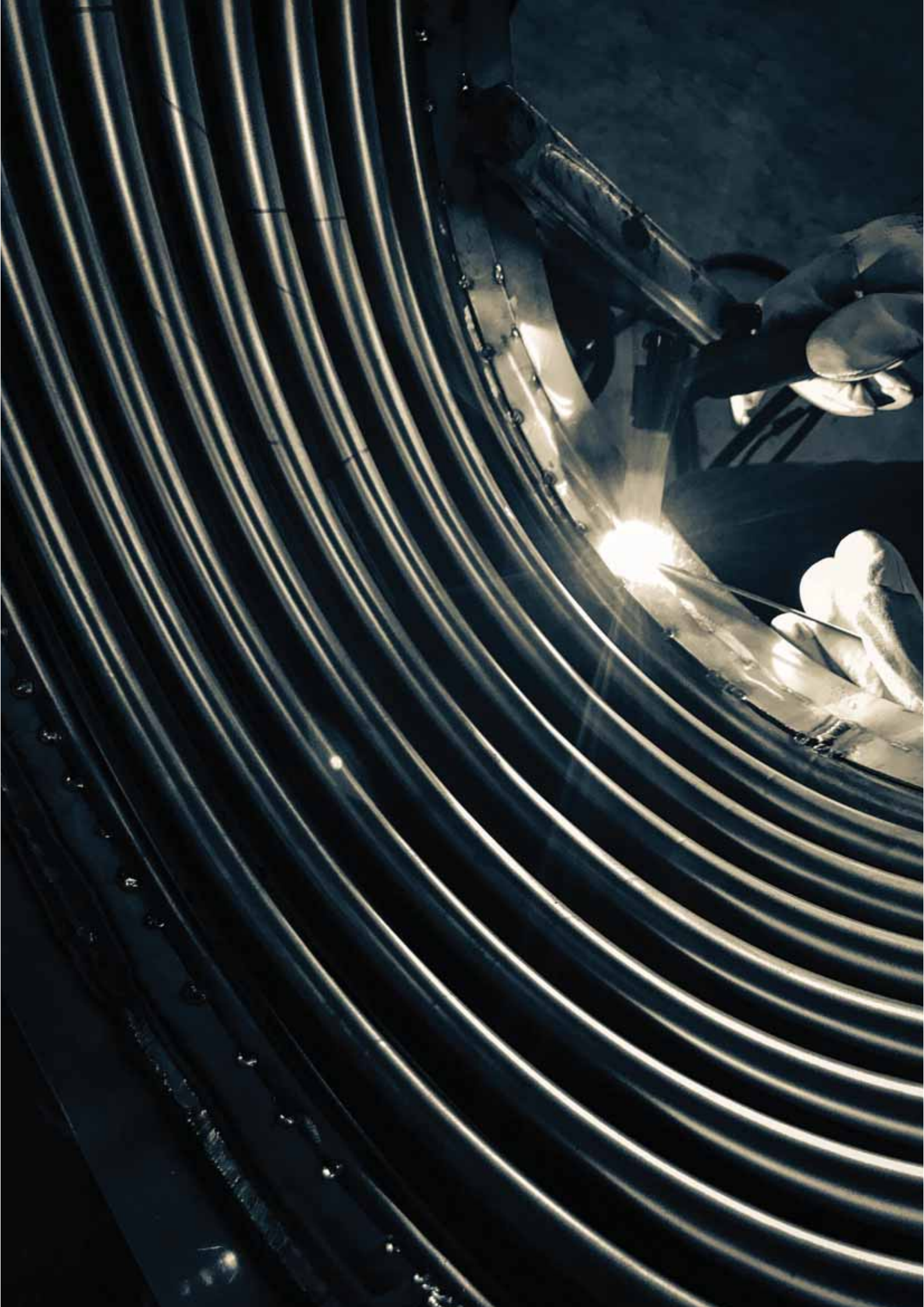
Part Number	Name
1	Flange Reinforcement
2	Pressure Bearing Layer
3,4	Insulation
5	Support Layer
6	Mechanical Reinforcement

### CONNECTION TYPES AND DIMENSIONS

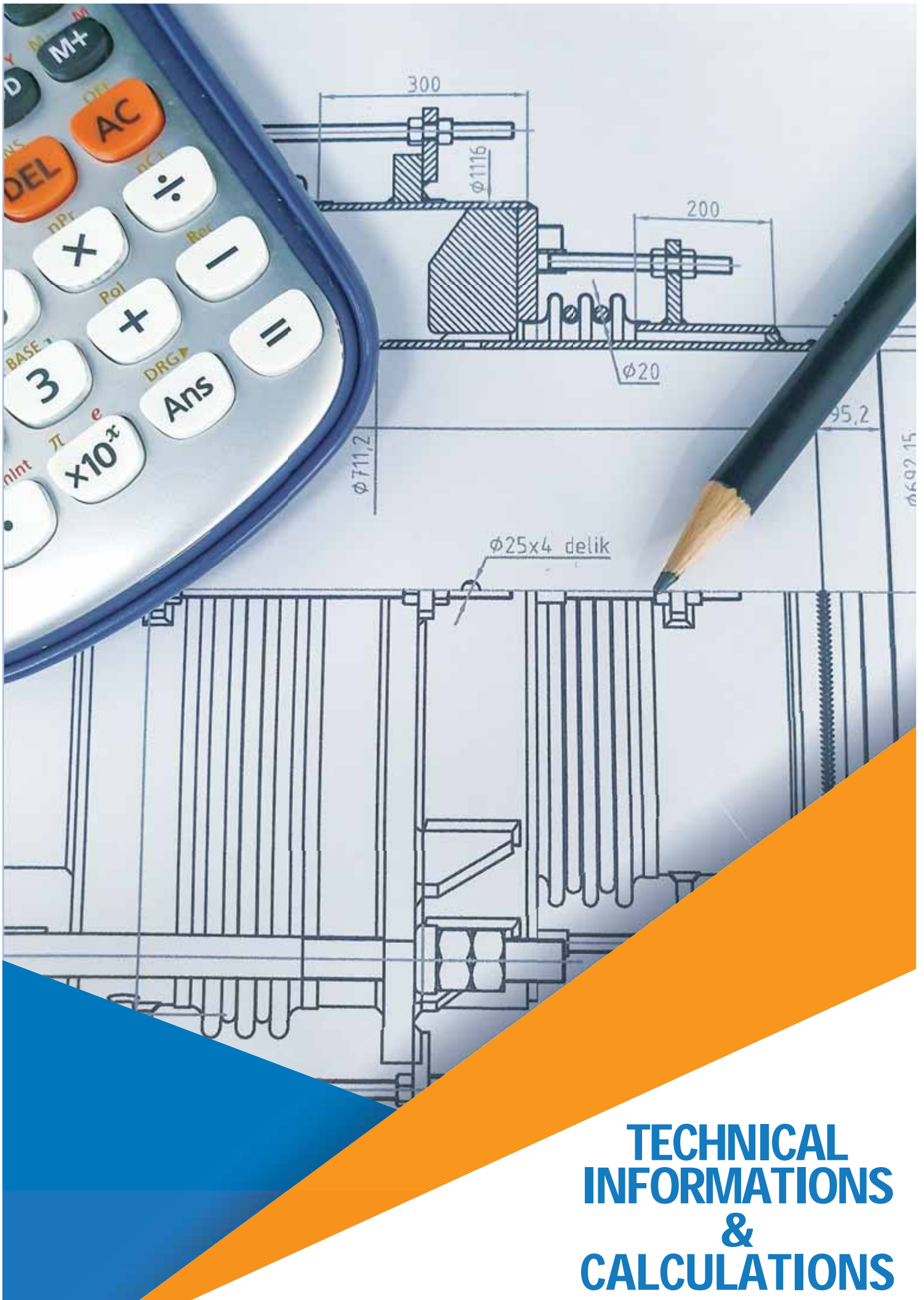
Connection	Circular or Rectangular
Temperature	Up to 1000 °C
Pressure	Max. 0,3 bar

\*\* Please contact our sales team for your requests.









**TECHNICAL  
INFORMATIONS  
&  
CALCULATIONS**

### 1.1 - Selection of Expansion Joints

The first step in the selection of Expansion Joints is to choose tentative locations for the pipe anchors. Any piping system, regardless of its complexity, can be divided into a number of individual expanding pipe sections having relatively simple configurations (ie: straight runs, "L" shaped bends, "Z" shaped bends and other means), by means of anchors. The number of pipe anchors selected, as well as their locations, will depend upon the piping configuration, the amount of expansion which can be accommodated by a single Expansion Joint, the availability of structural members suitable for use as anchors, the location of various pipe fittings, the location of connected equipment, the location of branch connections and other considerations.

The major pieces of connected equipment such as turbines, pumps, compressors, heat exchangers, reactors and similar devices can be considered as anchors in most applications. It is usually necessary to supplement these equipment anchor points by locating additional anchors at valves, at changes in the direction of the pipe, at blind ends of pipe and major branch connections. It is generally advisable to start out with the assumption that the use of single and double Expansion Joints in straight axial movement will provide the simplest and most economical layout, unless there are obvious advantages to be gained from another approach.

After anchor points have been tentatively located, the resulting pipe configurations should be reviewed to determine whether they conform to the standard pipe sections shown in section 1.2. At this point, consideration should be given to the relative merits of systems utilizing single and double Expansion Joints for axial movement only, as opposed to those utilizing universal, pressure balanced, hinged and gimbal Expansion Joints. A final decision on anchor locations and the types of Expansion Joints to be used can only be made after a comparison of various alternative solutions. Cost, the ability to comply with cyclic life and force requirements, space restrictions and similar items should be considered.

The next step is to calculate the actual change in length of each leg of each individual pipe section due to temperature changes. The minimum and installation temperatures are assumed to be 20 °C unless otherwise specified. An allowance, added by the system designer, should then be included in the actual calculated movements to account for the following possibilities:

- a. The minimum and/or installation temperatures used in the design calculations may have been based on the erroneous assumption that the metal temperature of the pipe is the same as the ambient temperature.
- b. During erection of the piping, it may be necessary to relocate some of the anchor point because of construction problems encountered at the job site.
- c. During operation the system may be subject to a different temperature range than the designer anticipated, particularly during start-up.

### 1.2 - Selection For Axial Movement Only

Figure 1.1 typifies good practise in the use of a single Expansion Joint to absorb axial pipe line expansion. Note the use of one Expansion Joint between two main anchors (M.A), the nearness of the Expansion Joint to an anchor, the closeness of the first alignment guide (G1), the spacing between the first alignment guide and the second alignment guide (G2), and the spacing of intermediate guides (G) along the balance of the line. See Figure 1.6



Figure 1.1

Figure 1.2 typifies good practise in the use of a double Expansion Joint to absorb axial pipe line expansion. Note the addition of the intermediate anchor (I.A) which, in conjunction with the the two main anchors, divides the pipe line into individual expanding sections, so that there is only one Expansion Joint between any two anchors. Note also the closeness guide and the second alignment guide (G1) to each Expansion Joint, the spacing between the first alignment guide and the second alignment guide (G2) and the spacing of intermediate guides (G) along the balance of each pipe section.

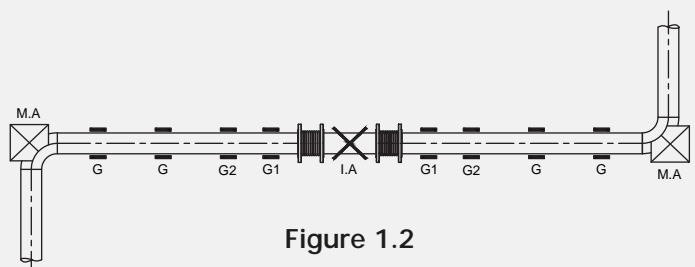


Figure 1.2



Figure 1.3 typifies good practice in the use of Expansion Joints to absorb axial pipe line expansion in a pipe line with a branch connection. The anchor at the junction, which in this case is a tee, is a main\*anchor (M.A) designed to absorb the thrust from the Expansion Joint in the branch line. Note the nearness of each Expansion Joint to an anchor, the closeness of each first alignment guide (G1), the spacing between the first alignment guide and the second alignment guide (G2) and the spacing of intermediate guides (G) along the balance of each pipe section.

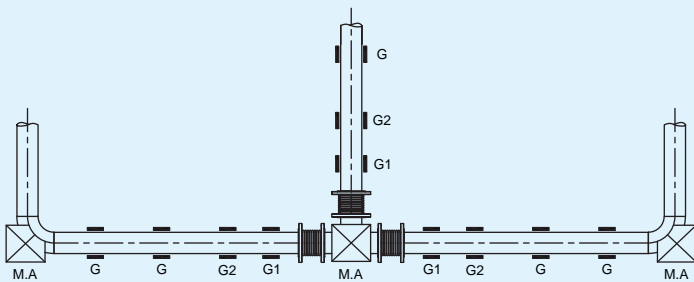


Figure 1.3

Figure 1.4 typifies good practice in the use of Expansion Joints to absorb axial pipe line expansion in a pipe line containing a reducer. The anchor at the reducer is a main anchor (M.A) designed to absorb the difference in the thrusts of the Expansion Joints on each side of the reducer. Note the nearness of each Expansion Joint to an anchor, the closeness of each first alignment guide (G1), the spacing between the first alignment guide and the second alignment (G2) and the spacing of intermediate guides (G) along the balance of each pipe section.

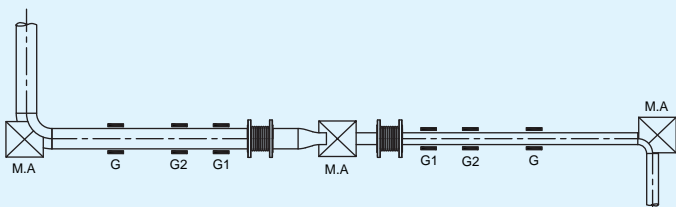


Figure 1.4

Figure 1.5 shows the application of a single Expansion Joint to a pipe line containing an offset. It should be noted that applications of this type are not usually recommended and will perform satisfactorily only within certain limits. As in Figure 1.1, the line is provide with main anchors at each end to absorb the pressure, movement loading, and guide friction. Where the line contains an offset, this load must first be transmitted through the offset leg, resulting in a moment on the piping. Where the line size is small, the offset appreciable, or where the pressure and movement forces are relatively high, this configuration may result in over-stressing, or distortion of the piping and guides.

Note the nearness of the Expansion Joint to an anchor (M.A), the closeness of the first alignment guide (G1), the spacing between the first alignment guide and the second alignment guide (G2) and the spacing of intermediate guides (G) along the balance of the line. Guides should be installed near both ends of the offset leg to minimize the effect of the bending moment on the system.

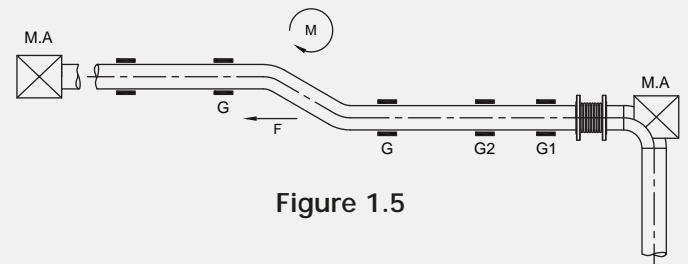


Figure 1.5

### 1.3 - Application Using Hinged Expansion Joints

Hinged Expansion Joints are usually used in sets of two or three, to absorb lateral deflection in one or more directions in a single plane piping system. Each individual Expansion Joint in such a system is restricted to pure angular rotation by its hinges. Each pair of hinged Expansion Joints, separated by a segment of piping, will act in unison to absorb lateral deflection in much the same manner as a swing or universal Expansion Joint in a single plane application. For a given angular rotation of the individual Expansion Joints, the amount of lateral deflection which a pair of hinged Expansion Joints can absorb is directly proportional to the distance between their hinge pins. In order to utilize the Expansion Joints most efficiently, this distance should be made as large as possible.

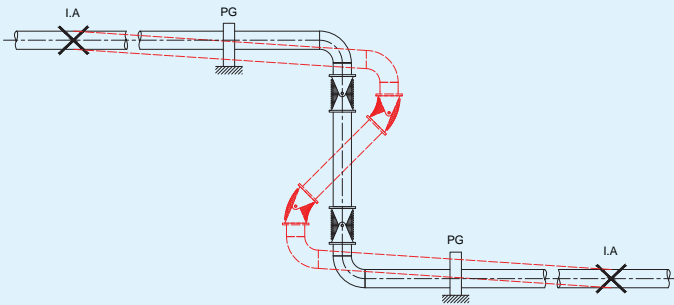


Figure 1.6

Figure 1.6 illustrates the use of a two-hinge system to absorb the major thermal expansions in a single-plane "Z" bend. Since the pressure thrust is absorbed by the hinges on the Expansion Joints, only intermediate anchors are required at each end of the piping system.

The thermal expansion of the offset section containing the Expansion Joints must be absorbed by bending of the piping legs perpendicular to that segment, since the Expansion Joints are restricted to pure angular rotation by their hinges and cannot extend or compress. The amount bending deflection imposed on each of two long piping legs may be controlled by proper design of guides and supports. Where one long leg is sufficiently flexible to absorb the full thermal growth of the offset leg, the other long leg may be controlled to permit longitudinal movement only.

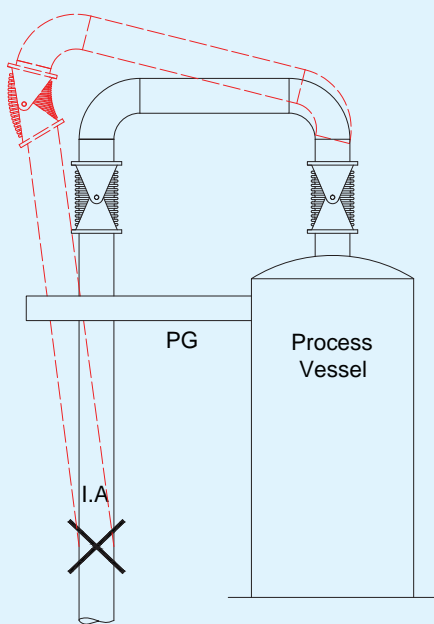


Figure 1.7

Figure 1.7 illustrates a two-hinge Expansion Joint system. In this case, the Expansion Joints will absorb only differential vertical growth between the vessel and pipe riser. Any horizontal movement due to piping expansion, vibration and wind loads will be absorbed by bending of the vertical pipe leg. A planar guide may be installed near the top of the vessel to protect the hinged Expansion Joints from wind loads at right angles to the plane of piping.

Where the piping system in a single plane system is not sufficiently flexible to absorb the bending deflections involved in a two hinge system or where the loads resulting from such bending exceed the allowable limits for connected equipment, a system of three hinged Expansion Joints may be used. Figure 1.8 illustrates a system of three hinged Expansion Joints in a single plane "Z" bend. The thermal expansion of the offset piping section is absorbed by the action of Expansion Joints B and C. It is therefore evident that Expansion Joint B must be capable of absorbing the total of the rotations of Expansion Joints A and C.

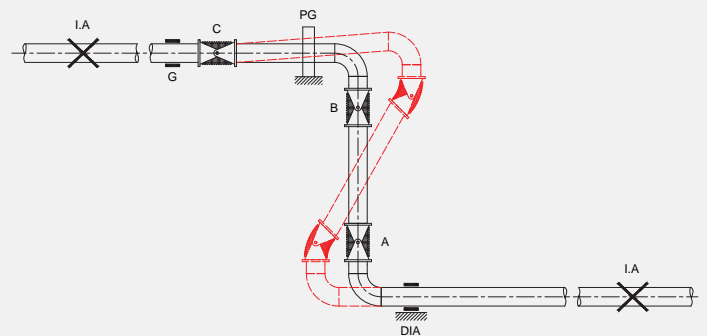
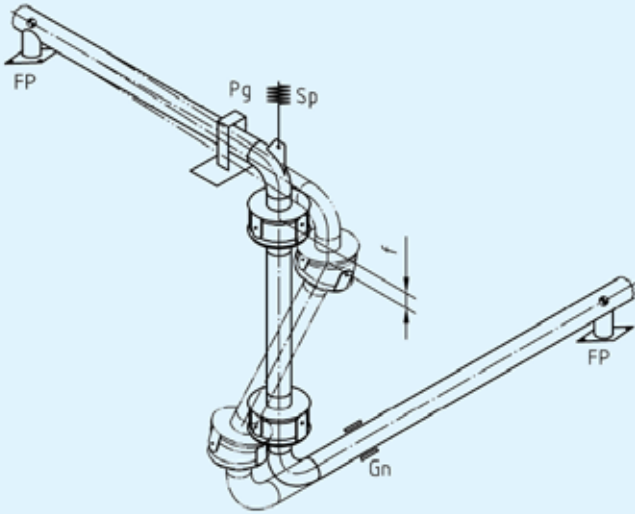


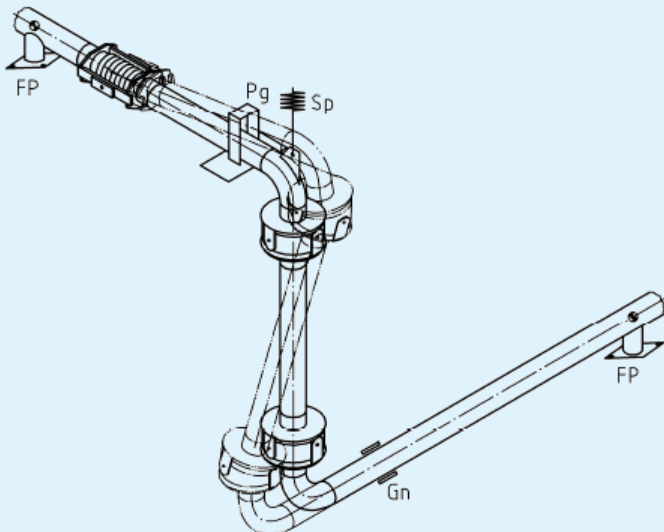
Figure 1.8

**1.3 - Application Using Gimbal Expansion Joints**



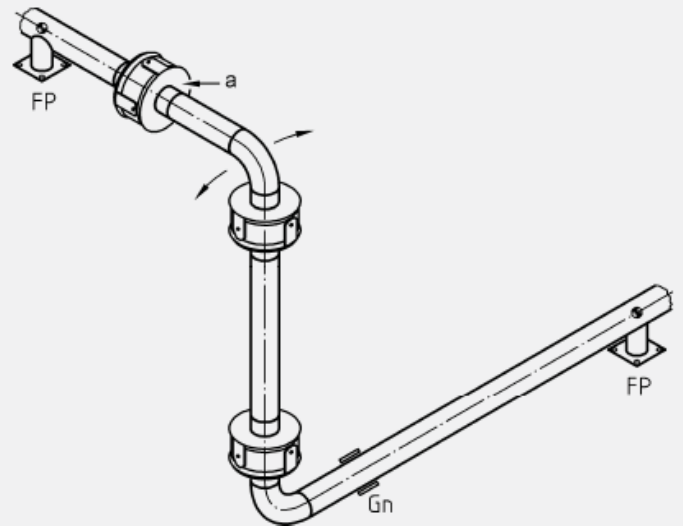
**Figure 1.9**

Just as hinged Expansion Joints may offer great advantages in single plane applications, gimbal Expansion Joints are designed to offer similar advantages in multi-plane systems. The ability of the gimbal Expansion Joint to absorb angular rotation in any plane is most frequently applied by utilizing two such units to absorb lateral deflection. An application of this type is shown in Figure 1.9. Since the pressure loading is absorbed by the gimbal structure, intermediate anchors only are required. Planar guides are provided to restrict the movement of each piping leg. As in the case of hinged Expansion Joints, the location of pipe supports is simplified by the load carrying ability of the gimbal structure. Since, in a two gimbal system, the growth of the vertical pipe leg will be absorbed by bending of the long legs, spring supports (SS) may be required on either or both of these. Guides must be designed to allow for the thermal expansion of the leg containing the Expansion Joints and for the shortening of this leg due to deflection.



**Figure 1.10**

Where it is impossible or undesirable for the piping to absorb the growth of the offset leg, a system consisting of two gimbal and one hinged Expansion Joint may be used as shown in Figure 1.10. The gimbal Expansion Joints function in unison to absorb the combined movements of the upper and lower legs, while the hinged Expansion Joint and the upper gimbal Expansion Joint act in combination to absorb deflection of the offset leg. Since the expansion of the offset leg takes place in one plane only, the use of the simpler hinged Expansion Joint is justified. The advantages of using gimbal Expansion Joint system are similar to those previously mentioned for system containing hinged Expansion Joints. Greater flexibility of usage is possible since gimbal Expansion Joints are not restricted to single plane systems.



**Figure 1.11**

In the system shown Figure 1.11, the position of the bellow is not clearly determined, only the stiffness of the bellows keeps the elbow in position. The use of three gimbals between two fixed points or anchors is not recommended. (a should be a hinged Expansion Joint)

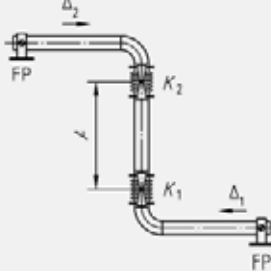
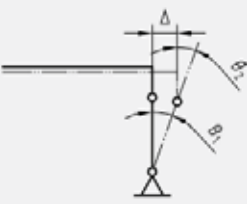
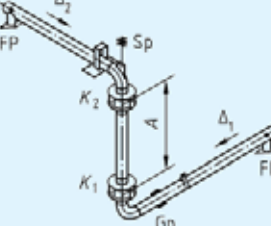
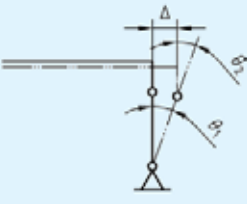
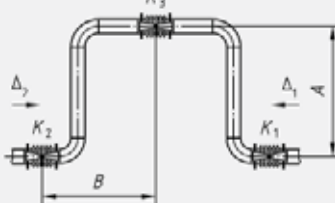
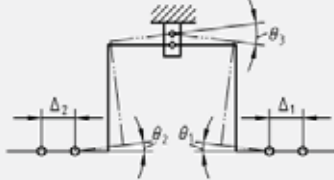
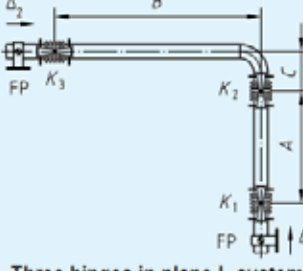
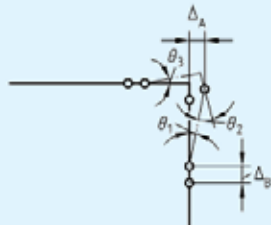
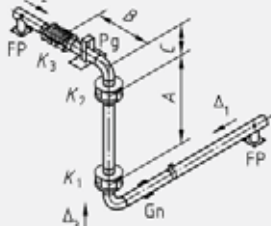
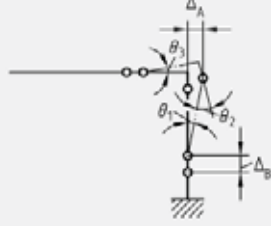
<p>1</p>	 <p><b>Double hinge in a plane Z-system</b></p>		$\Delta = \frac{1}{2} \cdot (\Delta_1 + \Delta_2)$ $\theta_1 = f(\Delta, A) \text{ find from Figure 1.13}$ $\theta_2 = \theta_1$
<p>2</p>	 <p><b>Double gimbal in a three-dimensional Z-system</b></p>		$\Delta = \frac{1}{2} \cdot \sqrt{\Delta_1^2 + \Delta_2^2}$ $\theta_1 = f(\Delta, A) \text{ find from Figure 1.13}$ $\theta_2 = \theta_1$
<p>3</p>	 <p><b>Three hinges in plane U-system</b></p>		$\Delta = \frac{1}{4} (\Delta_1 + \Delta_2)$ $\theta_1 = f(\Delta, A) \text{ find from Figure 1.13}$ $\theta_2 = \theta_1$ $\theta_3 = 2 \cdot \theta_1$
<p>4</p>	 <p><b>Three hinges in plane L-system</b></p>		$\Delta_A = \frac{1}{2} \cdot \left( \Delta_2 + \Delta_1 \cdot \frac{C}{B} \right)$ $\Delta_B = \frac{1}{2} \cdot \Delta_1$ $\theta_1 = f(\Delta_A, A)$ $\theta_3 = f(\Delta_B, B)$ $\theta_2 = \theta_1 + \theta_3$ <p>find from Figure 1.13</p>
<p>5</p>	 <p><b>Two gimbals and one hinge in a three-dimensional Z-system</b></p>		$\Delta_A = \frac{1}{2} \cdot \left( \sqrt{\Delta_1^2 + \Delta_2^2} + \Delta_3 \cdot \frac{C}{B} \right)$ $\Delta_B = \frac{1}{2} \cdot \Delta_3$ $\theta_1 = f(\Delta_A, A)$ $\theta_3 = f(\Delta_B, B)$ $\theta_2 = \theta_1 + \theta_3$ <p>find from Figure 1.13</p>

Table 1 - Calculation of the bending angles in hinge systems

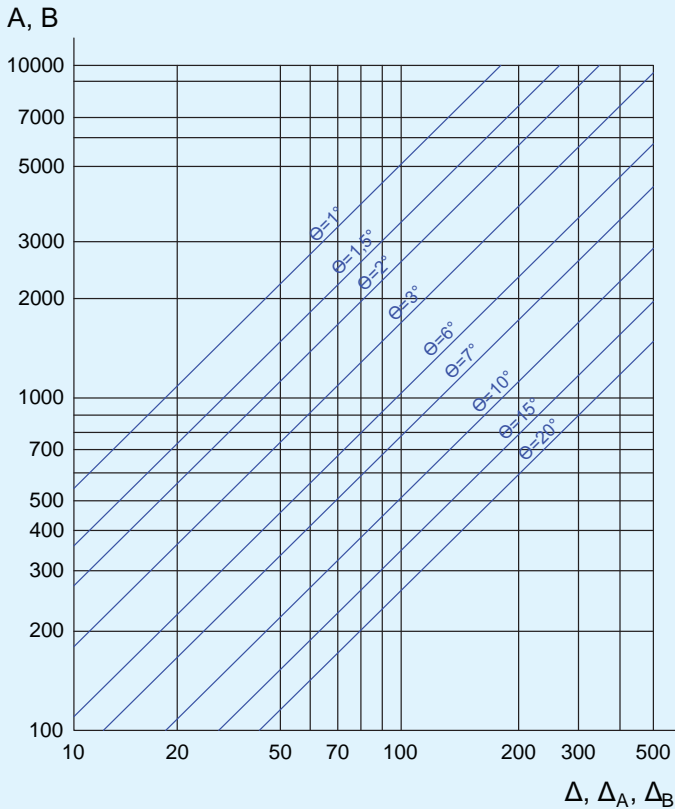


Figure 1.13

### 2.1 - Bellows

Bellows are the most important parts of KAYSE expansion joints. The bellows designed according to EN14917 or EJMA (Expansion Joints Manufacturers Association) standards are pressure, temperature resistant and highly flexible. Bellows are obtained by mechanical or hydraulic cold forming method. The bellows made of stainless steel consist of knuckles with a certain depth and width parallel to each other, thus the desired flexibility is provided.

The materials used for pressure-bearing parts in KAYSE expansion joints must be free from surface and internal defects which reduce suitability. The materials to be used for the bellows are selected in accordance with the manufacturing and welding methods. The preferred materials in the bellows design are given in Table 2. You can contact our technical team for specific materials not shown in the Table 2.

### 2.2 - Unreinforced Bellows

The equations for unreinforced bellows are based on those shown in Atomic International Reports NAASR- 4527 "Analysis of Stresses in Bellows, Part 1, Design Criteria and Test Results," with modifications and additions by the Association to reflect the experience of the members. These equations are based on elastic shell theory and consider the parameters involved for bellows of the "U" shaped configuration.

Type	MATERIAL		TEMPERATURE °C		DOCUMENT
	Nr	Name	Min.	Max.	
Stainless austenitic steels	1.4301	X5CrNi18-10	-196 <sup>a</sup>	550	EN 10028-7:2007
	1.4306	X2CrNi19-11	-270 <sup>a</sup>	550	
	1.4401	X5CrNiMo17-12-2	-196 <sup>a</sup>	550	
	1.4404	X2CrNiMo17-12-2	-270 <sup>b</sup>	550	
	1.4435	X2CrNiMo18-14-3	-270 <sup>a</sup>	550	
	1.4539	X1CrNiMoCuN25-20-5	-196 <sup>a</sup>	550	
	1.4541	X6CrNiTi18-10	-270 <sup>c</sup>	550	
	1.4550	X6CrNiNb18-10	-196 <sup>a</sup>	550	
1.4571	X6CrNiMoTi17-12-2	-270 <sup>c</sup>	550		
Heat resistant austenitic steels	1.4828	X15CrNiSi20-12	-196	900 <sup>d</sup>	Ek B, Konum 1
	1.4876	X10NiCrAlTi32-21 X10NiCrAlTi32-21 (H)	-196	600 900 <sup>d</sup>	Ek B, Konum 2.1 Ek B, Konum 2.2
Nickel alloys	2.4610	NiMo16Cr16Ti	-196	400	EAM-0526-28
	2.4816	NiCr15Fe	-10 (-270)	450 (900) <sup>d</sup>	EAM-0526-43-1, EAM-0526-43-2 ([9], [10])
	2.4819	NiMo16Cr15W	-196	400	EAM-0526-18
	2.4856	NiCr22Mo9Nb	-196 (-270)	450 (900) <sup>d</sup>	EAM-0526-40 ([11], [12])
	2.4360	NiCu30Fe	-196	425	Annex B, Position 3
	2.4858	NiCr21Mo	-270	540	Annex B, Position 4
	Ferritic steels	1.0345	P235GH	-20	400
1.0425		P265GH	-20	400	
1.5415		16Mo3	-20 <sup>e</sup>	500	
1.7335		13CrMo4-5	-20 <sup>e</sup>	500	EN 10028-3:2009
1.0565		P355NH	-20	400	
1.8935		P460NH	-20	400	

<sup>a</sup> Min. temperature according to EN 13445-2/Annex B or EN 13480-2/Annex B  
<sup>b</sup> Min. Temperature according to CERN  
<sup>c</sup> Minimum temperature for cold-rolled strip up to 6 mm and hot-rolled sheet up to 12 mm thickness.  
<sup>d</sup> Special care should be exercised due to the risk of embrittlement when using the materials at elevated temperatures above 550 °C.  
<sup>e</sup> Minimum temperature is possible when the specified minimum impact energy (normally 27 J) can be proved.

Table 2

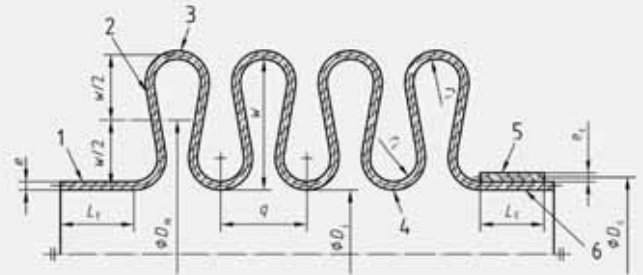


Figure 2.1 Unreinforced Bellows

### 2.3 - Reinforced Bellows

The equations for unreinforced bellows are based on those shown in Atomic International Reports NAASR- 4527 "Analysis of Stresses in Bellows, Part 1, Design Criteria and Test Results," with modifications and additions by the Association to reflect the experience of the members. These equations are based on elastic shell theory and consider the parameters involved for bellows of the "U" shaped configuration.

#### Key

- 1- end tangent without
- 2- corrugation
- 3- corrugation crest
- 4- corrugation root
- 5- reinforcing collar
- 6- end tangent with reinforcing collar

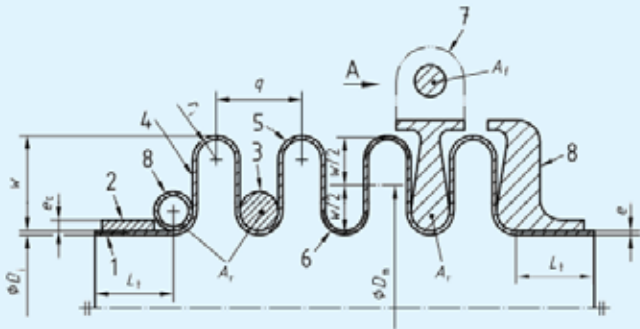


Figure 2.2 Reinforced Bellows

**Key**

- |                           |                     |
|---------------------------|---------------------|
| 1 end tangent corrugation | 5 Corrugation crest |
| 2 reinforcing collar      | 6 Corrugation root  |
| 3 reinforcing ring        | 7 Equalizing ring   |
| 4 corrugation             | 8 End ring          |

**2.4 - Internal Pressure Capacity**

Excessive hoop stress in the straight cylindrical end tangents of a bellows will cause circumferential yielding. This stress is calculated by a modification of the Barlow equation. For unreinforced bellows, a factor "k" is included which considers the stiffening effect of the attachment weld and the end convolution. When required, the straight tangent of unreinforced bellows can be reinforced by collars. The equations apportion the stress in the tangent and collar in relation to their respective cross sectional areas and material properties.

Excessive hoop stress in the convoluted section of the bellows can produce circumferential yielding and possible rupture. As in any cylindrical shell, this stress is inversely proportional to the cross sectional area. All equations apportion the stress between the bellows and any reinforcing members in relation to their respective cross sectional areas and material properties. Factors have been included to account for the effect of movement on the hoop stress.

Excessive internal pressure may cause a multiconvolution bellows to become unstable and squirm. Squirm is detrimental to bellows performance in that it can greatly reduce both fatigue life and pressure capacity. The two most common forms are column squirm and in-plane squirm. Column squirm is defined as a gross lateral shift of the center section of the bellows. It result in curvature of the bellows centerline as shown in Figure 2.3.



Figure 2.3

This condition is most associated with bellows which have a relatively large length to diameter ratio and is analogous to the buckling of a column under compressive load.

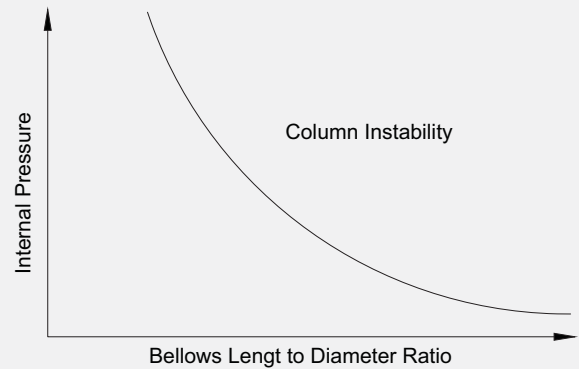


Figure 2.4

In-plane squirm, defined as a shift or rotation of the plane of one or more corrugations such that the plane of these corrugations is no longer perpendicular to the axis of the bellows, which remains more or less in line (see Figure 4). It generally appears for relatively small length - to - diameter ratio and is associated with high meridional bending stresses originating plastic hinges at the root and crest of the corrugations.

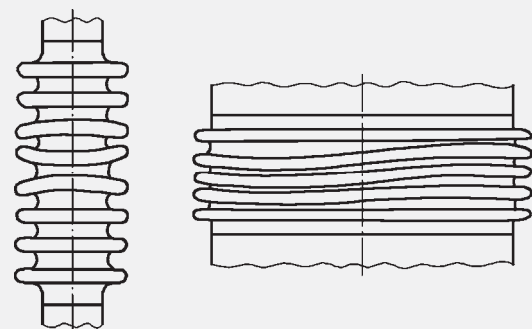
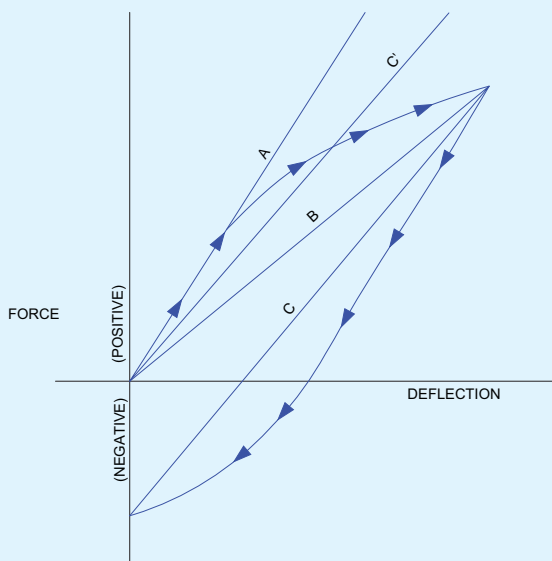


Figure 2.5 - In-Plane Squirm



## 2.5 - Bellows Spring Rate

The force required to deflect a bellows axially is a function of the dimensions of the bellows and the material from which it is made. The curve of force vs. deflection for most bellows indicates motion extending into the plastic range as shown by the solid line in Figure 2.6. The first portion of the curve is a straight line as the bellows is deflected through its elastic range. As bellows deflection continues and extend into the plastic range, the force vs. deflection relationship becomes non-linear until the point of maximum deflection is reached.



**Figure 2.6**

Line A in Figure 2.6 represents the bellows theoretical initial elastic spring rate  $K_B$ . This value can be determined analytically with reasonable accuracy from equations based on elastic theory. Lines B and C represent bellows resistance factors or working spring rates,  $K_w$ , for bellows with operating deflections in the plastic range. The use of the initial elastic spring rate in place of the working spring rate for a bellows whose deflection extends into the plastic range predicts forces which can be considerably higher than actual. This is recognized to be a problem and various methods have been used to obtain more accurate results. Line B, drawn from the origin to the point of maximum force and deflection, is used as the bellows working spring rate,  $K_w$  but has the disadvantage of underestimating the actual force over the full range. Line C, drawn from the point of maximum force and deflection to the value of the restoring force required to return the bellows to zero deflection, becomes line C' when transferred to the origin.

A working spring rate based on line C' can be used. This reduces the discrepancy between the indicated and true values although the difference can still be significant. For the great majority of applications, the manufacturers published spring rates have proved satisfactory. However, when the critical nature of a particular application warrants more precise knowledge of the bellows working spring rate., the user should require the manufacturer to supply information as to the means by which his data was developed. In special cases, prototype testing to determine the precise load vs. deflection characteristics of a particular bellows design may be necessary.

## 3.1 - Pipe Anchors

It is the purpose of any pipe anchor to divide a pipe line into individual expanding sections. Since thermal growth cannot be restrained, it then becomes the function of pipe anchors to limit and control the amount of movement which Expansion Joints, located between these anchors, must absorb. Major pieces of connected equipment such as turbines, pumps, compressors, heat exchangers and reactors may function as anchors. The design of such equipment must anticipate this loading. Additional pipe anchors are usually located at valves, at changes in the direction of the pipe, at blind ends of pipe and at major branch connections. Expansion Joints must be provided in each of the individual pipe sections provide adequate flexibility. Do not install more than one "single" Expansion Joint between the two adjacent anchors in any straight pipe section. Where expansion loops are used in the same line with an Expansion Joint, the section of pipe containing the loop must be isolated from the section containing the Expansion Joint by means of anchors. Pipe anchors, their attachment and the structures to which they are attached must be designed to withstand the forces acting upon them. Methods are given in the following paragraphs for determining the major forces to which anchors are subjected and it is on the basis of these major forces that anchors are classified as intermediate or main anchors. The system designer must realize that additional indeterminate forces can be imposed on both intermediate and main anchors. All components of the anchor should be designed to a conservative stress level.

### 3.2 - Pipe Guides and Guiding

Correct alignment of the adjoining pipe is of vital importance in the proper functioning of an Expansion Joint. Although Expansion Joints are designed and built for long and satisfactory life, maximum service will be obtained only when the pipe line has the recommended number of guides and is anchored and supported in accordance with good engineering practice. Proper supporting of the pipe line is required not only to support the live and dead loads imposed on the line but also to provide support for the Expansion Joint at each of its attachments. Pipeguides are necessary to insure proper application of movement to the Expansion Joint and to prevent buckling of the line. Buckling may be caused by a combination of two conditions:

(1) the flexibility of the Expansion Joint, and (2) the internal pressure loading on the pipe which causes it to act like a column loaded by the pressure thrust of the Expansion Joint. A typical application for pipe guiding is shown in Figure 1.1.

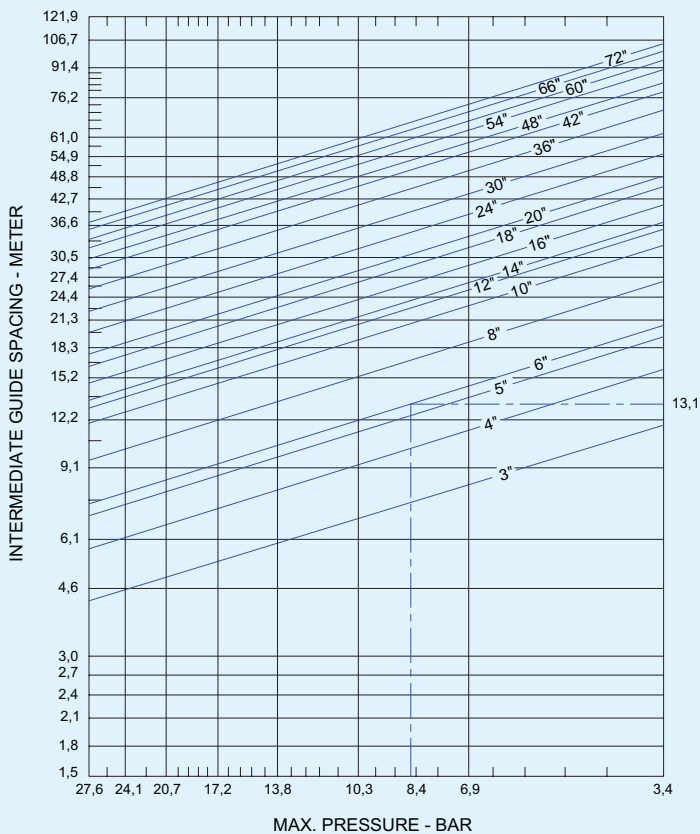


Figure 3.1

Maximum intermediate guide spacing for any pipe material or thickness shall be calculated using the following formula:

$$L_g = 0,131 \cdot \sqrt{\frac{E_p \cdot I_p}{P_d \cdot A_e \pm f_i \cdot e_x}}$$

**Key**

- $E_p$  : Modulus of Elasticity for pipe
- $I_p$  : Moment of inertia of pipe cross section (in<sup>4</sup>)
- $P_d$  : Design Pressure (psig)
- $A_e$  : Bellows effective area (in<sup>2</sup>)
- $f_i$  : Bellows axial spring rate per convolution (lb./in.)
- $e_x$  : Axial movement per convolution (in.)

**Note:** When bellows is compressed in operation, use (+)  $f_i \cdot e_x$ ; when extended use (-)  $f_i \cdot e_x$ .  
Guide spacing for standard wall carbon steel pipe may also be calculated in lieu of using figure 3.1.

**Caution:** The figure is based on average spring rate and bellows effective area with bellows inside diameters that equal pipe outside diameters. The formula is based on one half critical length of a pinned-pinned Euler column.

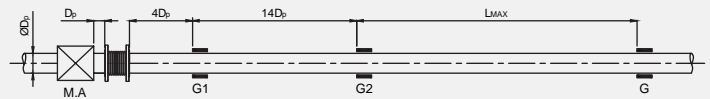


Figure 3.2

Dia. (mm)	ØD <sub>p</sub>	D <sub>p</sub> (mm)	4D <sub>p</sub> (mm)	14D <sub>p</sub> (mm)
15	21,3	21,3	85,2	298,2
20	26,9	26,9	107,6	376,6
25	33,7	33,7	134,8	471,8
32	42,4	42,4	169,6	593,6
40	48,3	48,3	193,2	676,2
50	60,3	60,3	241,2	844,2
65	76,1	76,1	304,4	1065,4
80	88,9	88,9	355,6	1244,6
100	114,3	114,3	457,2	1600,2
125	139,7	139,7	558,8	1955,8
150	168,3	168,3	673,2	2356,2
200	219,1	219,1	876,4	3067,4
250	273	273	1092	3822
300	323,9	323,9	1295,6	4534,6
350	355,6	355,6	1422,4	4978,4
400	406,4	406,4	1625,6	5689,6
450	457	457	1828	6398
500	508	508	2032	7112

Table 3 - Support and guide distances

### 3.3 - Main Pipe Anchors

A main anchor is one which is installed at any of the following locations in a piping system containing one or more unrestrained Expansion Joints: at a change in direction of flow, between two Expansion Joints of different size installed in the same straight run, at the entrance of a side branch containing an unrestrained Expansion Joint into the main line, where a shutoff of pressure reducing valve is installed in a pipe run between two Expansion Joints, and at a blind end of pipe.

A main pipe anchor must be designed to withstand the forces and moments imposed upon it by each of the pipe sections to which it is attached. In the case of a pipe section containing one or more Expansion Joints, these will consist of the full line thrust due to pressure and flow, the forces and/or moments required to deflect the Expansion Joint or Joints the full rated movement, and the frictional forces due to pipe alignment guides, directional anchors and supports. In certain applications, it may be necessary to consider the weight of the pipe, fittings, insulation and flowing medium, as well as various other forces and moments resulting from wind loading, bending of one or more pipe sections, etc. The net loading on the anchor can be calculated by a summation of the moments about the anchor point and by the vector addition of all forces acting upon it.

### 3.4 - Calculating of Main Anchor Loads

#### 3.4.1 - Pressure Thrust Force

Pressure thrust is the axial force emerging due to the effect of the pressure in the line Figure 3.3. It is calculated by the following formula;

$$F_p = P \cdot A_e \quad (2)$$

#### 3.4.2 - Spring Force

The axial spring force is the force required to extend or be able to compact an expansion expansion joint. (N)

$$F_B = \pm x \cdot K_B \quad (3)$$

#### 3.4.3 - Frictional Force

The axial spring force is the force required to extend or be able to compact an expansion expansion joint. (N)

$$F = \pm \Sigma (\mu \cdot F_N) \quad (4)$$

For calculation of the total axial frictional force, all individual forces acting on each guide within a section of straight pipe run have to be taken into consideration. These frictional forces will occur during movement of the system, primarily when temperature changes occur or for other reasons. They always act against the direction of movement which has to be regarded when deciding for the sign.

The value of  $\mu$  which is the friction coefficient of the guides and supports is given the pipe supports manufacturer and the vertical load  $F_N$  which comprises mainly weight loads is given by the stress analysis of the piping system.

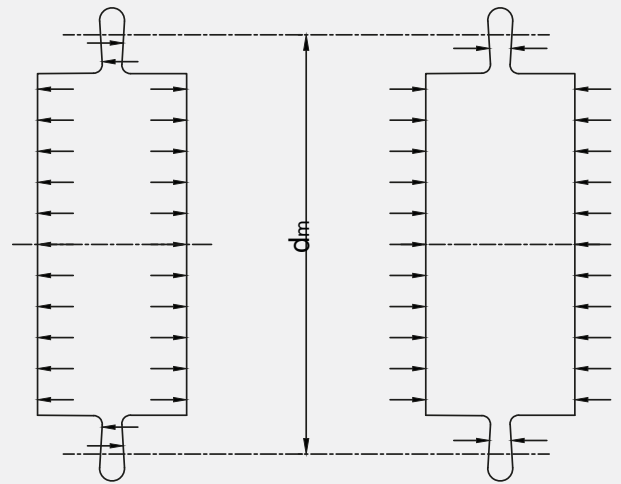


Figure 3.3

#### 3.4.4 - Total Force

Total force applied by the Expansion Joint to each fixed point;

$$F_T = F_p + F_B + F_F \quad (N) \quad (5)$$

#### Key

P	: Test Pressure	(N/mm <sup>2</sup> )
A <sub>e</sub>	: Bellows Effective Area	(mm <sup>2</sup> )
x	: Axial movement	(mm)
K <sub>B</sub>	: Bellows axial spring rate	(N/mm)
μ	: Friction coefficient	
F <sub>N</sub>	: Vertical load	(N)

#### 4 - Expansion / Compression Calculations

The expansion calculation in the pipes is made by the following formula depending on the material and length of the pipe used, the temperature of the fluid and the ambient temperature at which the pipe is laid.

$$\Delta l = \alpha(T-t)l \quad (6)$$

##### 4.1 Sample Calculation for Expansion

For a carbon steel heating line having a length of 35 meters, a temperature of 80/70 °C (Supply-Return);

$\alpha(\text{mm}/^\circ\text{C}\cdot\text{m}) : 0,011$  (See Table 4)

$l(\text{m}) : 35\text{m}$

$T(^\circ\text{C}) : 80^\circ\text{C}$

$t1 : 5^\circ\text{C}$

$\Delta T = 80 - 5 = 75^\circ\text{C}$

$\Delta l = \alpha \times l \times \Delta T$

$\Delta L = 0,011 \times 35 \times 75$

$\Delta L = 28,88 \text{ mm};$  chosen expansion joint should be axial type 60mm (-40, +20)

The value found according to the above calculation is the amount of expansion in the pipe. In regard to this extension, the expansion joint selection is made according to the negative (-) value of the expansion joint compression amount.

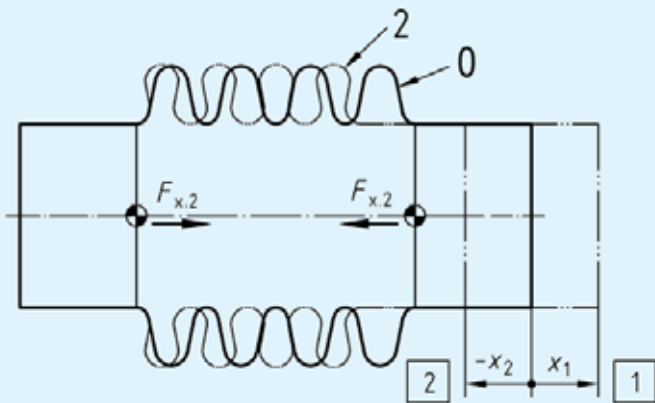


Figure 4.1 Bellows subjected to an axial displacement x

##### 4.2 - Sample Calculation for Compression

For a carbon steel cooling line having a length of 130 meters, a temperature of 7/12 °C

$\alpha(\text{mm}/^\circ\text{C}\cdot\text{m}) : 0,011$  (See Table 4)

$l(\text{m}) : 130\text{m}$

$T(^\circ\text{C}) : 7^\circ\text{C}$

$t1 : 20^\circ\text{C}$

$\Delta T = 7 - 20 = -13^\circ\text{C}$

$\Delta l = \alpha \times l \times \Delta T$

$\Delta L = 0,011 \times 130 \times (-13)$

$\Delta L = -18,59 \text{ mm};$  chosen expansion joint should be axial type 60mm (-40, +20) or 30mm (+20, -10)

The value found according to the above calculation is the amount of expansion in the pipe. In regard to this shrinkage, the expansion joint selection is made according to the negative (+) value of the expansion joint expansion amount.

Material	100 °C	200 °C	300 °C	400 °C	500 °C
Ferritic Steels	0,0125	0,013	0,0136	0,0141	0,0145
Austenitic Steels	0,016	0,0165	0,017	0,0175	0,018
Copper	0,0155	0,016	0,0165	0,017	0,0175

Table 4 - Mean thermal expansion coefficient  $\alpha$  in mm/mK

#### 5 - Internal Sleeves

Internal sleeves shall be specified for all Expansion Joints in the following cases;

- a. When it necessary to hold friction losses to a minimum and smooth flow is desired.
- b. When flow velocities are high and could produce resonant vibration of the bellows. Internal sleeves are recommended when flow velocities exceed the following values:

##### Air, Steam and other gases;

up to 6 in. dia. - 1,22 m./sec./inch of diameter  
over 6 in. diameter - 7,62 m./sec.

##### Water and other liquids;

up to 6 in. dia. - 0,61 m./sec./inch of diameter  
over 6 in. diameter - 3,04 m./sec.

**c.** When turbulent flow is generated within ten pipe diameters of the Expansion Joint by changes in flow direction, valves, tee or elbow sections or cyclonic devices. The actual flow velocity should be multiplied by 4

**d.** Specific applications must be evaluated individually. The lowest flow velocity which might produce an induced resonant vibration in the bellows may be calculated using the following equation:

$$v = \frac{.81 \cdot \sigma \sqrt{K_{ST}/W}}{C_v} \quad (7)$$

**Key**

- $\sigma$  : Inside convolution width (mm)
- $K_{ST}$  : Overall bellows spring rate (N/mm) [KB/N]
- $K_B$  : Axial spring rate of one bellows (N/mm)
- N : Number of convolution
- W : Weight of the bellows including reinforcement (N).

For liquid media, include the weight of liquid contained only between the convolutions.

Cv: Correlation factor used in the calculation of minimum flow velocity for the inclusion of internal liners in an Expansion Joint assembly. For U shaped convolutions,  $C_v$ : .22.

An internal sleeve must be used when the flow velocity exceeds 75% of the values calculated above.

**e.** When there is a possibility of erosion, as in lines carrying catalyst or other abrasive media, heavy gauge sleeves must be used. At no time should the relatively thin bellows be directly exposed to erosion.

**f.** When there is reverse flow, heavy gauge sleeves may be required, or the use of telescopic sleeves may be appropriate.

**g.** For high temperature applications to decrease the temperature of the bellows and enable the bellows metal to retain its higher physical properties. The annular area between the bellow and liner may be packed with a ceramic fiber insulation or a gas purge may be installed to further reduce the bellows effective temperature.

**h.** Internal sleeves should not be used where high viscosity fluids such as tars are being transmitted, since these fluids may cause "packing up", "coking" and "caking" which, may cause premature Expansion Joint failure. Where the fluid is such that purging will effectively prevent the "packing up", internal sleeves may be used in conjunction with purge connections.

**6 - Vibration**

Metal bellows can be used in applications where the vibration is of high frequency and low amplitude. They are not suitable for vibrations where the frequency is low and the amplitude high, such as those resulting from reciprocating machines. Vibrations which are the result of pressure pulses can not be removed by the installation of an Expansion Joint, since the pressure pulses are transmitted beyond the Expansion Joint through the flow media. In this case, a pulsation dampener is required.

The piping system designer should insure that vibration loads in his piping system will not be detrimental to the function of the bellows. In reducing or eliminating vibration effects the designer may wish to consider the use of external dampening devices or system mass adjustments.

Where flow velocities are high, turbulent flow generated within the bellows section or turbulence originating upstream of the bellows may induce vibration. To minimize this phenomenon, an internal sleeve must be used.

**6.1- Single Bellows**

When vibration is present and the frequency is known, the bellows shall be designed so that its natural frequency (fn) and higher modes do not coincide with the system frequency. To avoid a resonant response in the bellows, the bellows natural frequency shall be less than 2/3 of the system frequency or greater than 2 times the system frequency.

Axial Vibration: (Accordion Mode)

$$v = C_n \cdot \sqrt{\frac{K_{sr}}{W}} \text{ (hertz) (7)}$$

**Key**

**W:** Weigh of bellows including reinforcement (N). For liquid media, include the weigh of liquid contained only between the convolutions.

**Cn:** A constant used in the calculation of single bellows axial and lateral vibration frequencies. Use C1 for natural or fundamental frequency, C2 for first harmonic, etc.

**n:** 1, 2, 3, 4, 5 ....

Number of Convolutions	C1	C2	C3	C4	C5
1	8,84	-	-	-	-
2	9,51	17,7	23,1	-	-
3	9,75	18,8	26,5	32,5	36,2
4	9,75	19,1	27,8	35,4	41,6
5	9,81	19,3	28,4	36,8	44,2
6	9,81	19,4	28,7	37,5	45,6
7	9,81	19,5	28,9	38,0	46,6
8	9,81	19,5	29,1	38,0	47,1
9	9,81	19,5	29,1	38,5	47,5
10 & over	9,81	19,6	29,2	38,6	47,8

**Table 5 - Values of "C<sub>n</sub>"**

Lateral Vibration: (Beam Mode)

$$v = \frac{C_n \cdot D_m}{L_b} \cdot \sqrt{\frac{K_{sr}}{W}} \text{ (hertz) (8)}$$

Values of "C<sub>n</sub>" ;

C<sub>1</sub>: 24,8, C<sub>2</sub>: 68,2, C<sub>3</sub>: 133, C<sub>4</sub>: 221, C<sub>5</sub>: 330

**7 - Corrosion**

Corrosion can significantly reduce the service life of an Expansion Joint. The design and operating characteristics of Expansion Joints are such they may be subjected to corrosive attack under conditions which might not affect piping and fittings if similar materials. Possible types of corrosion that may be experienced in Expansion Joint applications are as follows:

- Stress-corrosion, which is evidenced by a cracking of the material as the result of a combination of stress and a corrosive environment
- Intergranular-corrosion, which is characterized by a preferential attack along the grain boundaries in metals
- Pitting, which is a localized attack on metals; general corrosion or the gradual eating away of the metals in a system
- Impingement and corrosion erosion, associated with the impact of a liquid or gas medium on the surface of the material under attack
- Elevated temperature oxidation is another form of material degradation most commonly encountered in hot air and exhaust lines.

Occurance of all types of corrosion depends upon the material type and condition, as well as its initial surface condition. Selection of the metarial type should be such that there is no possibility of corrosion occuring or that it is not affected by corrosion to an extend greater than 0,002 inches penetration per year.

The corrosion resistance of stainless steel depends on the formation of a thin, unbroken, chromic oxide surface, which will form slowly in the atmosphere on clean stainless steel. Particles of steel, such as welding spatter, will prevent the formation of this chromic oxide surface; therefore, to produce maximum general corrosion resistance, all scale should be removed by pickling. Theadherence of welding spatter should be prevented both in the shop and during installation by covering the bellows or by using an anti-spatter compound. Although it is sometimes desirable to heat treat austenitic stainless steel piping components in order to improve their resistance to corrosion, this is not usually the case with bellows. Expansion Joint bellows are invariably used at movements producing high stresses, frequently within the plastic range; thus, any benefical effect of removing residual stresses would be quickly nullified by operating stresses. The possible occurance of stress corrosion in austenitic stainless steel bellows cannot be eliminated by heat treatment or by reducing the movement.



Saturated Liquid - Temperature Table			
Saturated Press. <b>P<sub>doy</sub> (kPa)</b>	Saturated Temp. T (°C)	Specific Volume (m <sup>3</sup> /kg)	
		Saturated Liquid v <sub>f</sub>	Saturated Steam v <sub>g</sub>
1.0	6.97	0.001000	129.19
1.5	13.02	0.001001	87.964
2.0	17.50	0.001001	66.990
2.5	21.08	0.001002	54.242
3.0	24.08	0.001003	45.654
4.0	28.96	0.001004	34.791
5.0	32.87	0.001005	28.185
7.5	40.29	0.001008	19.233
10	45.81	0.001010	14.670
15	53.97	0.001014	10.020
20	60.06	0.001017	7.6481
25	64.96	0.001020	6.2034
30	69.09	0.001022	5.2287
40	75.86	0.001026	3.9933
50	81.32	0.001030	3.2403
75	91.76	0.001037	2.2172
100	99.61	0.001043	1.6941
125	105.97	0.001048	1.3750
150	111.35	0.001053	1.1594
175	116.04	0.001057	1.0037
200	120.21	0.001061	0.88578
225	123.97	0.001064	0.79329
250	127.41	0.001067	0.71873
275	130.58	0.001070	0.65732
300	133.52	0.001073	0.60582
325	136.27	0.001076	0.56199
350	138.86	0.001079	0.52422
375	141.30	0.001081	0.49133
400	143.61	0.001084	0.46242
450	147.90	0.001088	0.41392
500	151.83	0.001093	0.37483
550	155.46	0.001097	0.34261
600	158.83	0.001101	0.31560
650	161.98	0.001104	0.29260
700	164.95	0.001108	0.27278
750	167.75	0.001111	0.25552

Table 6 - Saturated Water Pressure Table

Saturated Liquid - Temperature Table			
Saturated Press. <b>P<sub>doy</sub> (kPa)</b>	Saturated Temp. T (°C)	Specific Volume (m <sup>3</sup> /kg)	
		Saturated Liquid v <sub>f</sub>	Saturated Steam v <sub>g</sub>
800	170.41	0.001115	0.24035
850	172.94	0.001118	0.22690
900	175.35	0.001121	0.21489
950	177.66	0.001124	0.20411
1000	179.88	0.001127	0.19436
1100	184.06	0.001133	0.17745
1200	187.96	0.001138	0.16326
1300	191.60	0.001144	0.15119
1400	195.04	0.001149	0.14078
1500	198.29	0.001154	0.13171
1750	205.72	0.001166	0.11344
2000	212.38	0.001177	0.099587
2250	218.41	0.001187	0.088717
2500	223.95	0.001197	0.079952
3000	233.85	0.001217	0.066667
3500	242.56	0.001235	0.057061
4000	250.35	0.001252	0.049779
5000	263.94	0.001286	0.039448
6000	275.59	0.001319	0.032449
7000	285.83	0.001352	0.027378
8000	295.01	0.001384	0.023525
9000	303.35	0.001418	0.020489
10,000	311.00	0.001452	0.018028
11,000	318.08	0.001488	0.015988
12,000	324.68	0.001526	0.014264
13,000	330.85	0.001566	0.012781
14,000	336.67	0.001610	0.011487
15,000	342.16	0.001657	0.010341
16,000	347.36	0.001710	0.009312
17,000	352.29	0.001770	0.008374
18,000	356.99	0.001840	0.007504
19,000	361.47	0.001926	0.006677
20,000	365.75	0.002038	0.005862
21,000	369.83	0.002207	0.004994
22,000	373.71	0.002703	0.003644
22,064	373.95	0.003106	0.003106

Table 6 (Continued)

Name	Concentration (%)	Temperature (°C)	Ferritic Steels	Austenitic Steels	2.4858 / Incoloy 825	2.4816 / Inconel 600	2.4856 / Inconel 625	2.4819 / Hastelloy C-276	Titanium	Nickel
Acetanilide		<114	0	0	0	0	0	0	0	0
Acetic Acid	5	20	0	0	0	1	0	0	0	3
	5	bp	3	0	0	1	0	0	0	1
	50	20	3	0	0	1	0	0	1	3
	50	bp	3	3	0	1	0	0	0	3
	80	20	3	P	0	1	0	0	0	3
	96	20	3	3	0	1	0	0	0	3
Acetic acid vapour	33	20	3	1						
	100	>50	3	3	0	1		0	0	3
	100	<bp	3	3	0	3		0	0	3
Acetic aldehyde	100	bp	1	0	0	0	0	0	0	0
Acetone	100	bp	0	0	0	0	0	0	0	0
Acetyl chloride		20	1	1	1	1	0	0	1	
Acetylene (dr)		20	0	0	0	0	0	0	0	0
		200	0	0	0	0	0	0	3	0
Adipic Acid	all	200	0	0	0	0	0	0	0	0
Allyl alcohol	100	bp		0	0	0	0	1		0
Allyl chloride	100	25					0	0		0
Aluminium chloride (hy)	5	20	3	3	1	1	0	0	1	0
Aluminium fluoride (hy)	10	25	3	3				1	1	0
Aluminium hydroxide (hy)	10	20	3	0	0		0	0	0	
Aluminium nitrate			0	0	0	0	0	0	0	
Aluminium oxide		20	1	0	0	0	0	0		
Aluminium sulphate (hy)	10	<bp	3	3	0	1	0	1	0	1
	15	50	3	3		1	1	1	0	1
Ammonia (dr)	10	20	0	0	0	0	0	0	0	3
Ammonia (hy)	2	20	0	0	0	0	0	0	0	3
	20	40	0	0	0	1	1	1	0	3
	sa	bp	0	0	0	3	1	1	0	
Ammonia Bromide (hy)	10	25	P	P	0		0	1		
Ammonium Acetate				0	0					
Ammonium Bicarbonate (hy)				0	0	1	3			
Ammonium Carbonate (hy)	1	20	0	0	0	0	0	1		
	50	bp	0	0	0	0	0	1		1
Ammonium chloride (hy)	1	20	P	P	0	0	0	0	0	1
	10	100	P	P	0	0	0	0	0	1
	50	bp	P	P	0	1	0	1	0	1
Ammonium fluoride	10	25	1	0				0	1	
Ammonium fluoride (hy)	20	80		3				0		
Ammonium hydroxide	100	20	0	0	0	0	0	0	0	0
Ammonium nitrate (hy)	5	20	0	0	0	1	0	0		
	100	bp	0	0	0			0		
Ammonium sulphate (hy)	1	20	0	0	0	1	0	0	0	1
	10	20	1	1	0	3		1	3	1
Ammonium sulphite	cs	20	1	0	3	3			0	3
	sa	bp	3	1	3	3			0	3
Antifreeze		20	0	0	0	0	0	0	0	0
Arsenic		65		0						
Arsenic Acid (hy)		20		0						
	90	110	3	3		3				
Asphalt		20	0	0						0
Benzene	100	20	0	0	0	0	0	1	0	0
	100	bp	0	0		1	1	1	1	1
Benzine	100	25	0	0	0	0	0	0	0	0
Boiled Oil		20	0	0	0	0	0	0	0	0
Borax (hy)	cs		0	0						0
	sa		0	0						0
Boric acid (hy)	50	100	0	0	0	1	0	0	0	1
	50	150	1	0	0	1	0	0	0	1
	70	150	1	1	0	1	0	0	0	1

Name	Concentration (%)	Temperature (°C)	Ferritic Steels	Austenitic Steels	2.4858 / Incoloy 825	2.4816 / Inconel 600	2.4856 / Inconel 625	2.4819 / Hastelloy C-276	Titanium	Nickel
Butane	100	20	0	0	0	0	0	0	0	0
	100	120	1	0						
Butanol	100	20	0	0	0	0	0	0	0	0
	100	bp	0	0	0	0	0	0	0	0
Calcium carbonate		20	0	0	0	0	0	0	0	0
Calcium chloride (hy)	5	100	P	P				0	0	
	10	20	P	P	0	0	0	0	0	0
	cs		P	P	0	0	0	0	0	1
	sa		3	P	0	0	0	0	0	P
Calcium hydroxide			0	0	1	1	0	0	0	1
Calcium nitrate		20	0	0	0	0	0	0	0	0
Calcium nitrate	all	100	0	0	0	0	0	0	0	0
Calcium oxide		20	0	0	0	0	0	0	0	0
Calcium sulphate (mo)		20	0	0	0		0	0	0	0
		bp	0	0	0		0	0	0	0
Calcium sulphite (hy)	cs		0	0						0
	sa		0	0						0
Cabon dioxide (dr)	100	<540	1	0	0	0	0	0	0	0
	100	1000				3				
Cabon dioxide (mo)	20	25	1	0	0	0	0	0	0	
	100	25	1	0	0	1	0	0	0	1
Chloric acid (hy)		20	3	3	0			0	0	
Chloroform (dr)			1	1	0	0	0	0	0	0
Chloroform (mo)			P	P	0	0	0	0		0
Chromic acid (hy)	5	20	3	0	1	3	0	0	0	3
	5	90	3	3				1	0	3
	10	20	0	0	1	3		0	0	3
	10	65	3	3				0	0	3
	10	bp	3	3	1	3		0	0	3
	50	bp	3	3	3	3		3	0	3
	60	20	3	3	1	3		0	3	
Diethyl ether			0	0	0	0	0	0	1	0
Ethane		20	0	0	0	0	0	0	0	0
Ethyl alcohol	all	20	0	0	0	0	0	0	0	0
	all	bp	0	0	0	0	0	0	0	0
Ethylbenzene			0	0	0	0	0	0	0	0
Ethylene		20	0	0						
Ethylene glycol	100	20	0	0	0	1	0	0	0	1
Gluconic acid	100	20	0	0	0	0	0	0	0	0
Glucose (hy)		20		0	0					0
Glycol	100	20	0	0	0	1	0	0	0	1
		20	1	1				0	0	
Glycolic acid		bp	3	3				0	0	
		20	0	0				0	0	0
Nitric Acid	1	20	0	0				0	0	0
	1	bp	0	0				1	0	3
	5	20	0	0	0	3		0	0	3
	5	bp	1	0				1	0	
	10	bp	1	0				1	0	3
	15	bp	1	0				3	0	
	25	bp	3	0				3	1	
	50	bp	3	3	0	3		3	1	3
	65	20	0	0		0		0	0	
	65	bp	3	3	0	3		3	0	3
	99	bp	3	3	0	3		3	0	3
Hydrochloric acid	20	290	3	3				3	3	
	40	200	3	3				3	3	
	0.2	20	3	P				0	0	P
	0.5	20	3	3				0	0	
	1	20	3	3	3	3		0	0	1
15	20	3	3	3	3		0	3	3	
32	20	3	3				0	3		

Name	Concentration (%)	Temperature (°C)	Ferritic Steels	Austenitic Steels	2.4858 / Incoloy 825	2.4816 / Inconel 600	2.4856 / Inconel 625	2.4819 / Hastelloy C-276	Titanium	Nickel
Hydrogen		<300		0				0		
		>300		0				0		
Hydrogen chloride (dr)		20	3	1	0	0	0	0		
		100	3	3	0	0	0	0		
		250	3	3	0	0	0	0		
		500	3	3	1		0			
Hydrogen cyanide (dr)		20	0	0	0	1	0	0	0	0
Hydrogen cyanide (hy)	20	20	1	0	0	1	0	0	0	0
	cs	20	1	0	0	0	0	0	0	0
Hydrogen fluoride	5	20	3	3	3	0	0	0	3	0
	100	500	3	3	3	3	0	3	0	0
Hydrogen peroxide	all	20	3	0	0	1	0	0	1	3
Ketene		20	0	0	0	0	0	0	0	0
		bp	0	0	0	0	0	0	0	0
Lactic acid (hy)	1	20	3	0	0	0	0	0	0	0
	all	20	3	1				0	0	0
	10	bp	3	3	0	3		0	0	3
	all	bp	3	3				0	0	
Lactose (hy)		20	0	0	0	0	0	0	0	0
Lead (me)		388	1	1		0			0	
		900	3	3				0		
Lead acetate (me)			0	0				0		
Lime		20	0	0	0	0	0	0	0	0
Lithium (me)		300	0	0	0	0	0	0	0	0
Lithium Chloride (hy)	cs		3	3	0	0	0	0	0	0
Lithium hydroxide (hy)	all	20	0	0	0	0	0		0	0
Magnesium (me)		650	1	3	3	3		3	0	3
Magnesium carbonate (hy)		20	0	0	0	0	0	0	0	0
		bp	0	0	0	0	0	0	0	0
Magnesium chloride (hy)	5	20	3	P	0	0	0	0	0	0
	5	bp	3	3	0	0	0	0	0	0
	50	bp	3	3				0	0	
Magnesium hydroxide (hy)	cs			0	0	0	0	0	0	0
	sa			0	0	0	0	0	0	0
Magnesium nitrate	cs		0	0	3	3		3	0	3
Magnesium oxide	cs		0	0	0	0	0	0	0	0
	sa		0	0	0	0	0	0	0	0
Magnesium sulphate (hy)	0.1	20	1	0				0	0	
	5	20	1	0	0	1	0	0	0	1
	50	bp	1	0				1	0	
Mallic Acid (hy)		20	3	0	0	1	0	0	0	3
		50	100	3	0	0	1	0	0	3
Methanol (Methyl alcohol)		<100	20	0	0	0	0	0	0	0
		100	bp	3	1		0	0	0	0
Methylamine (hy)		25	20	0	0	0	0	0	0	
Methyl chloride (dr)		100	20	0	0	0	0	0	0	0
Methyl chloride (mo)		20	P	P		0	0	0		
		100	P	P		0	0	0		
Methylene dichloride (dr)		20	P	P				0		
Methylene dichloride (mo)		20	P	P	0		1	1	0	1
		bp	P	P	1		1	1	0	1
Naphthaline		100	20	0	0				0	
Nitric Acid	1	20	0	0				0	0	0
	1	bp	0	0				1	0	3
	5	20	0	0	0	3		0	0	3
	5	bp	1	0				1	0	
	10	bp	1	0				1	0	3
	15	bp	1	0				3	0	
	25	bp	3	0				3	1	
	50	bp	3	3	0	3		3	0	1
65	20	0	0		0		0	0		

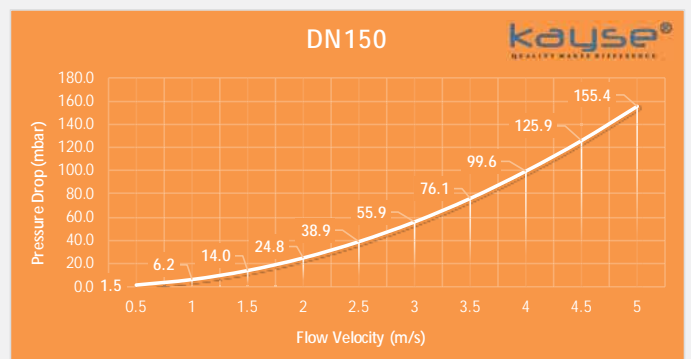
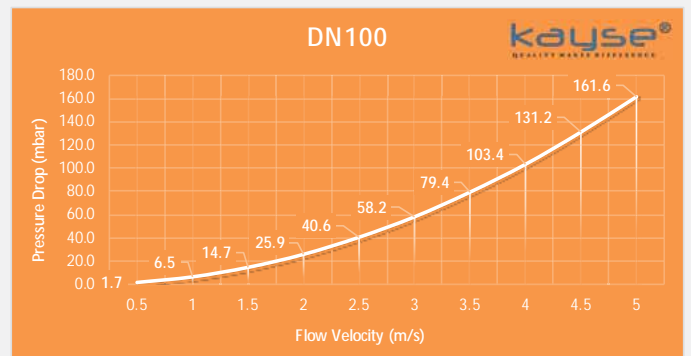
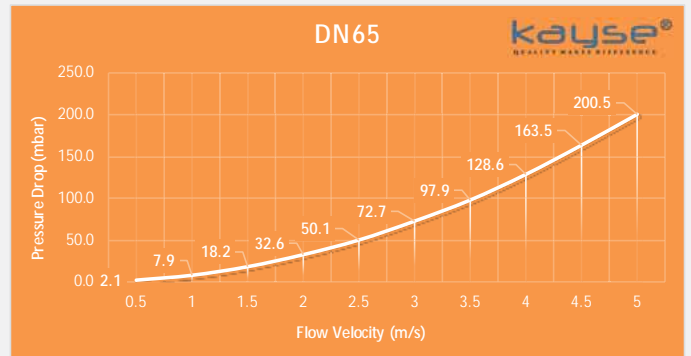
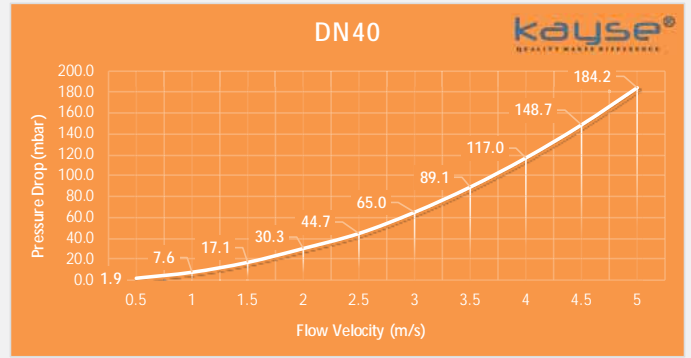
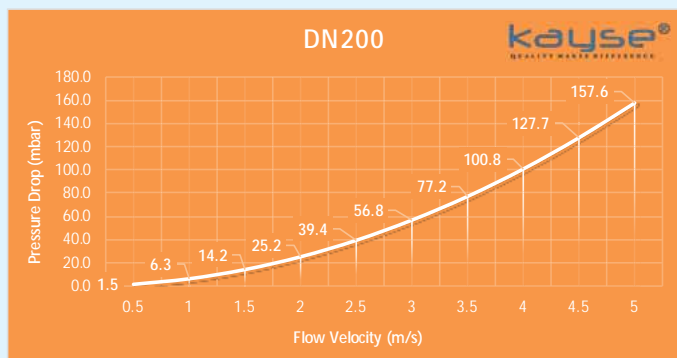
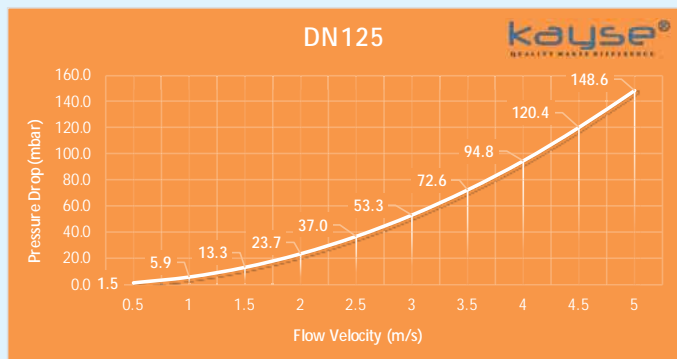
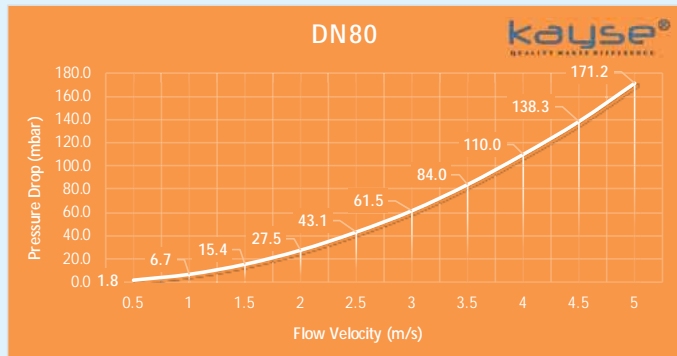
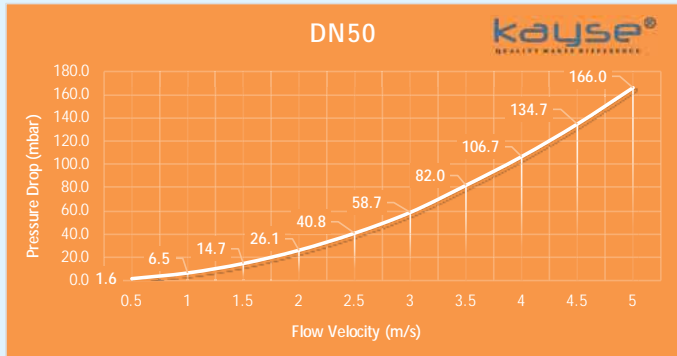
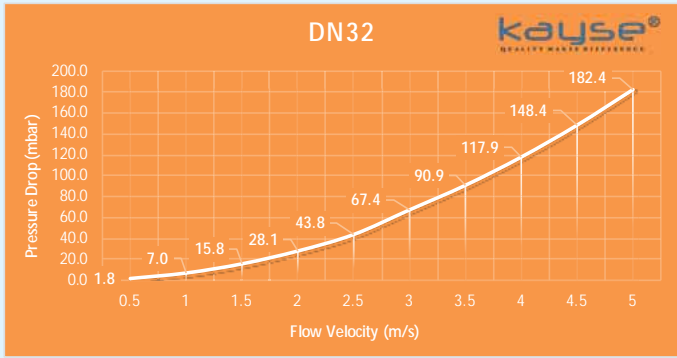
Name	Concentration (%)	Temperature (°C)	Ferritic Steels	Austenitic Steels	2.4858 / Incoloy 825	2.4816 / Inconel 600	2.4856 / Inconel 625	2.4819 / Hastelloy C-276	Titanium	Nickel
Nitric Acid	65	bp	3	3	0	3		3	0	3
	99	bp	3	3	0	3		3	0	3
	20	290	3	3				3	3	
	40	200	3	3				3	3	
Nitrogen		100	20	0		0	0	0	0	0
Oxygen		500	0	0						
Ozone			0	0	0	0	0	0	0	0
Petroleum		20	0	0	0	0	0	0	0	0
		bp	0	0	0	0	0	0	0	3
Petrol	100	20	0	0	0	0	0	1	0	0
	100	bp	0	0	0	1	1	1	1	1
Phosphoric acid (hy)	1	20	0	0	0	0	0	0	0	0
	10	20	3	0				0	0	
	30	bp	3	1				1	3	3
	60	bp	3	3				1	3	
	80	20	3	1		0	0	0	0	3
	80	bp	3	3		0		3	3	3
Phosphorus (dr)		20	0	0						
Potassium (me)		604		0				1	0	
Potassium acetate (me)	100	292		0					0	
Potassium acetate (hy)		20	0	0		0	0	0	0	0
Potassium bromide	5	30	P	P	0	1	0	0	0	0
Potassium carbonate (hy)	50	20	0	0	0	0	0	0	0	0
	50	bp	3	0	0	0	0	0	0	0
Potassium chloride (hy)	10	20	3	P	0	0	0	0		
	10	<bp	3	P				1		
	30	bp	3	P				1	0	
	cs		P	P				1		
	sa		3	P				1		
	10	20		0	0	0	0	0	0	0
Potassium chromate (hy)	10	bp		0				0		
Potassium cyanide (hy)	10	20	0	0	0	3		0		3
	10	bp	0	0						
Potassium hydroxide (hy)	10	20	0	S	1	1	1	1	0	0
	10	bp	0	S	1	1	1	1	0	0
	30	bp	3	S	1	3			1	3
	50	20	0	S	1	1	1	0	0	0
	50	bp	3	3	1	3		1	3	0
	sa		3	S				1		
Potassium hydroxide (me)	100	360	3	3		3		3	0	3
Potassium hypochloride (hy)	all	20	P	P	3	3		0	0	3
	all	bp	P	P	3	3		1	0	3
Potassium iodide (hy)		20	P	P	0	1	1	0	0	3
		bp	3	P	0	1	1	0	0	3
Potassium Nitrate (hy)	all	20	0	0	0	1	1	1	0	1
	all	bp	0	0				1	0	
Potassium sulphate (hy)	10	25	0	0	0	0	0	0	0	1
	all	bp	0	0	0	0	0	0	0	0
Soap (hy)	1	20	0	0		0	0		0	0
	1	75	0	0						0
	10	20	0	0						0
Sodium (O <sub>2</sub> ≤ 0.005 %) (me)		200	0	0						0
		600	0	0						0
Sodium acetate (hy)	10	25	0	0		0	0	0	0	0
	sa		0	0				0	0	
Sodium bicarbonate (hy)	10	20	0	0	0	1	1	1	0	1
	cs		0	0	0	1	0	0	0	1
Sodium bisulphate (hy)	sa		0	0				1	0	
	all	20	3	3	0	1	1	1	0	1

Name	Concentration (%)	Temperature (°C)	Ferritic Steels	Austenitic Steels	2.4858 / Incoloy 825	2.4816 / Inconel 600	2.4856 / Inconel 625	2.4819 / Hastelloy C-276	Titanium	Nickel
Sodium bisulphite (hy)	10	20	3	0				1	0	0
	50	20	0	0				1	0	0
	50	bp	3	3					0	0
Sodium borate (hy)	cs		0	0	0		0	0	0	
Sodium borate (me)			3	3				3		
Sodium carbonate (hy)	1	20	0	0	0	1	0	0	0	0
	all	bp	0	0	0	0	0	0	0	0
		400	3	3						
Sodium carbonate (me)		900	3	3						0
Sodium chloride (hy)	0.5	20	P	P	0	1	0	0	0	1
	2	20	P	P	0	1	0	0	0	1
	cs		P	P	0	1	0	0	0	1
	sa		3	3	0	1	0	1	0	1
Sodium chromate (hy)	all	bp	0	0	0	0	0	0		
Sodium hydroxide (solid)	100	all	0	0	0	0	0	0	0	0
Sodium hydroxide (hy)	<10	<60	0	0	0	0	0	0	0	0
	<10	<bp	3	0		0	0	0	0	0
	<20	<60	0	0		0	0	0	0	0
	<20	<bp	3	0		0	0	0	0	0
	<40	<60	0	0		0	0	0	0	0
	<40	<100	3	3		0	0	0	0	0
	<50	<60	0	0		0	0	0	0	0
	<50	<100	3	3		0	0	0	0	0
	<60	<90	3	0		0	0	0	0	0
	<60	<140	3	3		3	0	3		0
<60	>140	3	3		3	0	3		0	
Sodium hyposulphite	all	20	3	0	0	1	1	1	1	1
	all	bp	3	0	0	1	1	1	1	1
Sodium nitrate (hy)	5	20	0	0	0	0	0	0	0	1
	10	20	0	0	0	0	0	1	0	1
	<10	bp	0	0				0	0	1
	30	20	0	0	0	0	1	1	0	1
	30	bp	0	0	0	0		3	0	1
Sodium nitrate (me)		320	0	0				0	0	1
Sodium nitrite		20		0	1	0	0	0	0	3
Sodium peroxide (hy)	10	20	1	0	1	1	1	1	3	0
	10	bp	3	0	1	1	1	1	3	1
Sodium peroxide (me)		460			3	1		3		0
Sodium phosphate (hy)	10	20	0	0	0	0	0	0	0	0
	10	bp	0	0	0	0	0	0	0	0
Sodium sulphate (hy)	cs		0	0	0	0	0	0	0	0
	10	20	0	0	0	0	0	0	0	0
	cs		1	0	0	1	0	0	0	1
Sodium sulphide (hy)	sa		3	0	0	0	0	0	0	0
	1	20	0	0	0	0			0	1
	cs	20	3	3	0	1	0	0	0	1
	sa		3	3					0	
Sulphur (dr)	100	60	0	0				0	0	0
Sulphur (me)		130	0	0		0		0	0	3
		240	0	0				0	0	
Sulphur (mo)		20	2	1				0	0	3
Sulphur dioxide (dr)	100	20	0	0	0	0	0	0	0	0
	100	60	3	1				0	0	0
Sulphur dioxide (mo)	100	20	3	3	0	0	0	0	0	0
	0.05	20	1	0					0	
	0.05	bp	1	1					1	
	0.1	20	3	0					0	
	0.2	bp	3	3					1	
	0.8	bp	3	3					1	
	1	20	3	1		1	0	0	0	0
3	bp	3	3				1	1		

Name	Concentration (%)	Temperature (°C)	Ferritic Steels	Austenitic Steels	2.4858 / Incoloy 825	2.4816 / Inconel 600	2.4856 / Inconel 625	2.4819 / Hastelloy C-276	Titanium	Nickel
Sulphuric acid	5	bp	3	3	1	3		3	3	3
	7.5	20	3	1					1	
	10	bp	3	3	1	3		3	3	3
	25	20	3	3				0	3	
	25	bp	3	3				3	3	
	40	20	3	3				0	1	
	40	bp	3	3				3	3	
	50	20	3	3	1	3		0	3	3
	50	bp	3	3	3	3		3	3	3
	60	20	3	3				0	3	0
	80	20	3	1				0	3	
	90	20	3	1				0	3	
	96	20	1	1				0	3	1
		20	0	0					0	
Tar										
Tartaric acid (hy)	10	20	0	0	0	1	0	0	0	1
	10	bp	1	0	0	3		1	3	1
	25	20	1	0		0		0	0	
	25	bp	3	1		0		1	1	
	50	20	3	0				0	0	
	50	bp	3	3				1	3	
Uric acid (hy)		20	0	0	0	1	0	0	0	
		100	0	0	0	1	0	0	0	
Wine		20	0	0		0				
Yeast		20	0	0	0	0	0	0	0	0
Zinc chloride (hy)	5	20	P	P	0	1	0	0	0	1
	5	bp	3	3	0	3		1	0	1
	10	20	P	P					0	0
	20	20	P	P					0	
	75	20	3	P					0	
Zinc sulphate (hy)	2	20	0	0				0	0	
	20	bp	0	0				1	0	
	30	bp	3	0				1	0	
	cs		0	0	0	1	0	1	0	1
	sa		3	0	0			1	0	

Assessment	Corrosion Behaviour	Suitability
0	Resistant	Suitable
1	Reduction in thickness 1 mm/year	Restricted Suitability
P	Risk of pitting corrosion	Restricted Suitability
2	Up to 10 mm per year	Not Recommended
3	Not resistant	Unsuitable
Abbreviations		
dr	Dry Conditions	
mo	Humid Conditions	
hy	Liquid Solution	
me	Melted	
cs	Cold Saturated (Ambient Temp.)	
sa	Saturated (Boiling Point)	
bp	Boiling Point	

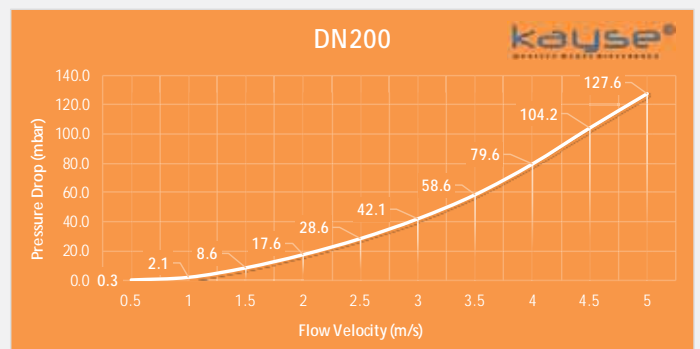
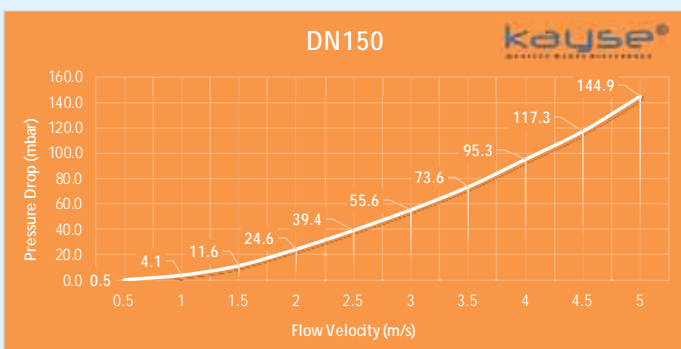
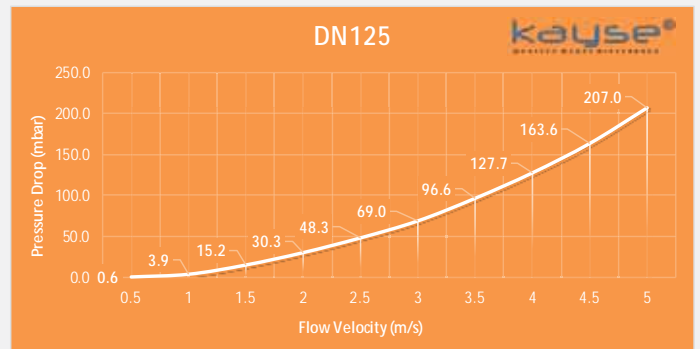
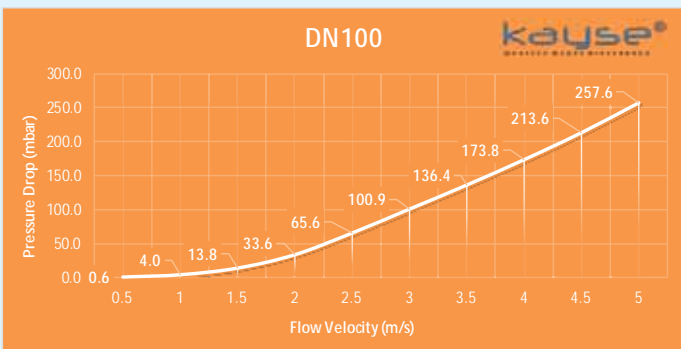
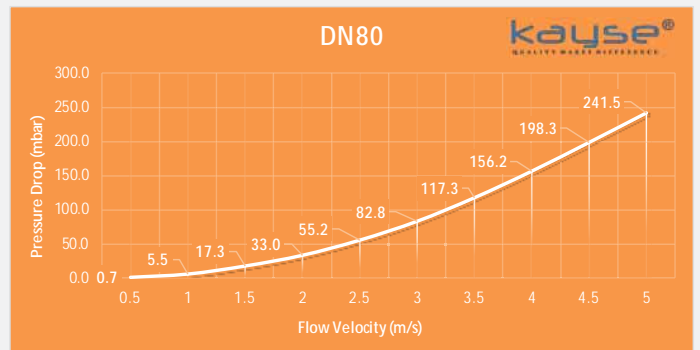
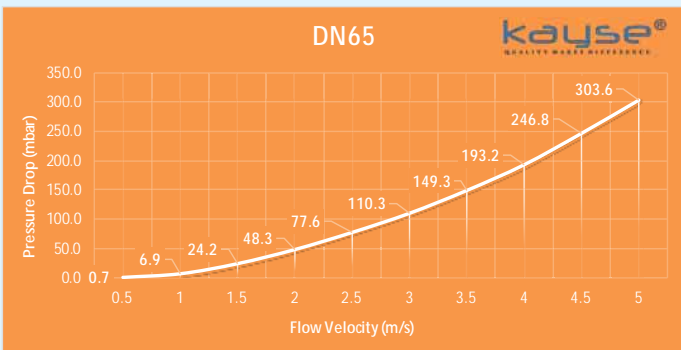
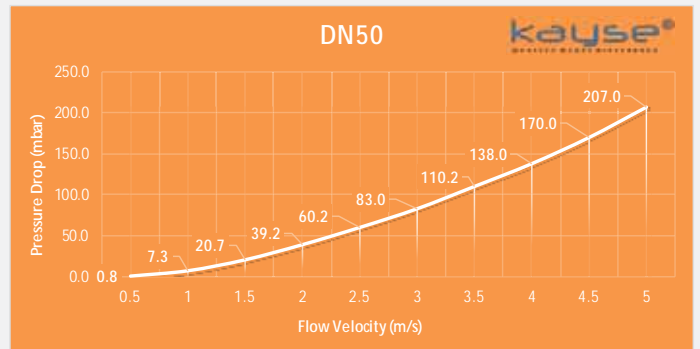
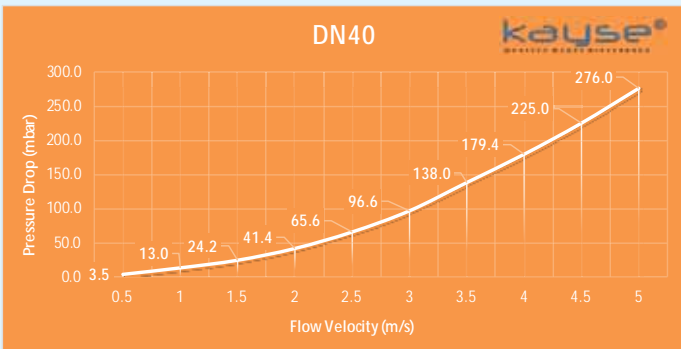
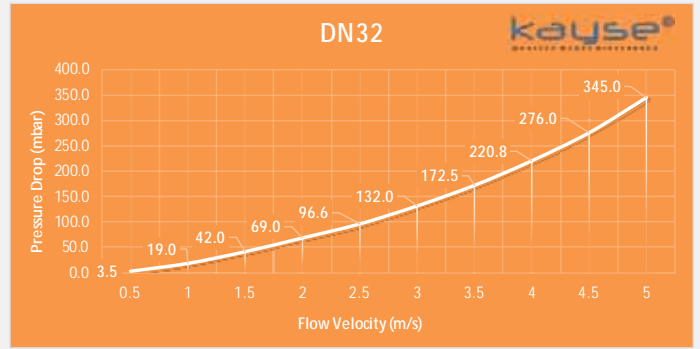
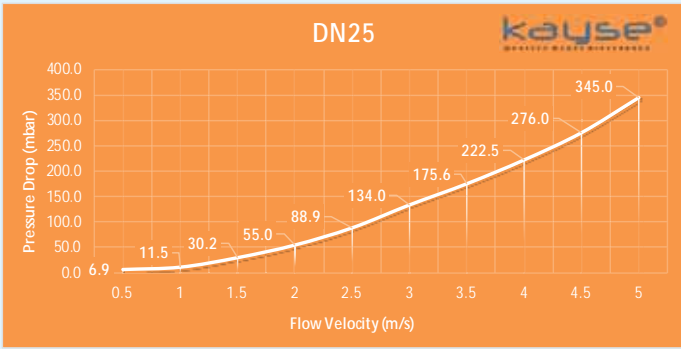
9 - Pressure Drops for Bellow



Pressure drop test conditions;

- Fluid : Water
- Temperature : 20°C
- Pressure : 16 bar
- Product : Axial Metal Expansion Joints
- Product Movement : 30mm

10 - Omega Loop Pressure Drops





## 11 - Typical Causes of Expansion Joint Failure

Bellows Expansion Joints will give many years of satisfactory service when they are properly designed and manufactured for specified piping system conditions. Failures can occur for many reasons, but experience has shown that certain causes of failure fall into fairly distinct categories. The following are some

### typical causes:

- Denting or gouging of bellows from being struck by hard objects (tools, chain falls, forklifts, adjacent structures, etc.)
- Improper stacking for shipping or storage.
- Insufficient protection from weather or other adverse environmental conditions.
- Joints with internal liners installed in reverse direction with respect to flow.
- Installing a joint in a location other than as prescribed by the installation drawings.
- Premature removal of shipping devices
- Springing of bellows to make up for piping misalignment.
- Insufficient protection from mechanical damage due to work in the surrounding area.
- Insufficient protection of bellow during nearby welding operations.
- Failure to remove shipping devices before system operation.
- Improper anchoring, guiding, supporting of the piping system.
- Anchor failure in service.
- Improper selection of bellows material for the flowing medium and/or adverse external environment. Specifically, chlorides leaching from insulation, have been frequently the cause of stainless steel bellows corrosion.

Stress corrosion cracking (consult material manufacturer for proper selection).

- System over-pressurization (in-service hydrotest).
- Bellows vibration (mechanical or flow-induced) resulting in fatigue failure.
- Excessive bellows movement (axial, lateral and angular movement greater than design values).
- Bellows without internal liner installed in a system having a very high velocity and/or erosive flowing medium.
- Packing or particulate matter in bellows convolutions which inhibits proper movement of the bellows.

# ULUSLARARASI STANDARTLAR YÜKSEK TEKNOLOJİ

kayse®

KALİTE FARK YARATIR

# kayse®

KALİTE FARK YARATIR



Tepeören Mah. İstanbul Tuzla Organize Sanayi Bölgesi (İTOSB)

7. Cadde No:4 34959 Tuzla / İstanbul

+90 216 304 00 65 +90 216 304 14 54

info@kayse.com.tr • satis@kayse.com.tr

www.  
kayse  
.com.tr